



**UNIVERSIDAD NACIONAL AUTÓNOMA DE MÉXICO
POSGRADO CONJUNTO EN CIENCIAS MATEMÁTICAS**

Combinatoria Infinita Aplicada a la Topología

TESIS

QUE PARA OPTAR POR EL GRADO DE
DOCTOR EN CIENCIAS MATEMÁTICAS

PRESENTA:
ARTURO ANTONIO MARTÍNEZ CELIS RODRÍGUEZ

Director de Tesis:
Dr. Michael Hrusak
Posgrado Conjunto en Ciencias Matemáticas

Morelia, Michoacán. Mayo del 2018.



Universidad Nacional
Autónoma de México

Dirección General de Bibliotecas de la UNAM

Biblioteca Central



UNAM – Dirección General de Bibliotecas
Tesis Digitales
Restricciones de uso

DERECHOS RESERVADOS ©
PROHIBIDA SU REPRODUCCIÓN TOTAL O PARCIAL

Todo el material contenido en esta tesis esta protegido por la Ley Federal del Derecho de Autor (LFDA) de los Estados Unidos Mexicanos (México).

El uso de imágenes, fragmentos de videos, y demás material que sea objeto de protección de los derechos de autor, será exclusivamente para fines educativos e informativos y deberá citar la fuente donde la obtuvo mencionando el autor o autores. Cualquier uso distinto como el lucro, reproducción, edición o modificación, será perseguido y sancionado por el respectivo titular de los Derechos de Autor.

Resumen/Abstract

En esta tesis se usan métodos de la combinatoria infinita para estudiar problemas de la teoría de conjuntos y topología. En particular, se estudian los temas de ideales Canjar, conjuntos fuertemente porosos y los espacios de Michael. Se estudiarán las relaciones que tienen los ideales Canjar con los conjuntos F_σ y se analizarán las propiedades de los ideales Canjar generados por familias casi ajenas. También se estudiarán los invariantes cardinales de los conjuntos fuertemente porosos y se dará una fuerte conexión con el forcing de Sacks y algunos números de Martin. Por último, se introducirá una nueva propiedad de ultrafiltros para estudiar el problema de los espacios de Michael, se estudiarán algunos invariantes cardinales asociados a este tipo de ultrafiltros y se analizará el comportamiento de estos ultrafiltros en varios modelos conocidos de la teoría de conjuntos.

In this dissertation we will use methods from infinite combinatorics to study problems from set theory and topology. In particular, we will study some topics related to Canjar ideals, strongly porous sets and Michael spaces. We will study the relationship between Canjar ideals and F_σ sets. We will also analyze some properties of Canjar ideals generated by almost disjoint families. We will also study the cardinal invariants associated to the σ -ideal generated by strongly porous sets, we will uncover a link between strongly porous sets, the Sacks forcing and a special kind of Martin numbers. Finally, we will introduce a new property of ultrafilters in order to study the Michael space problem. We will study some cardinal invariants associated to this kind of ultrafilters and we will also analyze the behavior of these ultrafilters in many known models of set theory.

Agradecimientos

Primeramente agradezco al Dr. Michael Hrušák por haberme guiado durante mis estudios de maestría y doctorado. Agradezco a todos mis profesores, en especial al Dr. Fernando Hernández, por haber compartido su conocimiento y su experiencia conmigo. Agradezco también a mis hermanos académicos: Osvaldo Guzmán, Jonathan Cancino, Jose de Jesús Pelayo, Sonia Navarro, Ariet Ramos y David Meza, cuyas charlas me ayudaron a crecer como matemático. Un agradecimiento a todos mis amigos, los cuales me han ayudado a superar mis problemas. Un especial agradecimiento a mi familia, quien siempre me ha apoyado en todo. Mi agradecimiento va dirigido también para la Universidad Michoacana de San Nicolás de Hidalgo y para la Universidad Nacional Autónoma de México, las cuales son dos instituciones que me apoyaron durante todos mis estudios de posgrado. Finalmente agradezco a CONACyT (número de beca 332652) por haberme brindado gran parte de los recursos para mis estudios de posgrado.

Introduction

The aim of this work is to study the methods from infinitary combinatorics that can be applied to other branches of mathematics, in particular to analysis and topology. The main topics of this work are going to be concepts related to F_σ -sets. Our most important tools are going to be cardinal invariants of the continuum and forcing.

In chapter one we will give an introduction to the most basic concepts that we will use in this work. This chapter will include a quick review of notions such as Borel set and p -point. We will state without proof some of the most important and basic theorems in topology, descriptive set theory, infinitary combinatorics and forcing. We will also give a quick review to some of the most basic models in set theory.

In chapter two we study the concept of Canjar filters, a notion introduced by Canjar in 1988. We will uncover a connection between Canjar filters, F_σ ideals and concepts closely related to p^+ -filters. Then, we will focus our attention to ideals generated by MAD families; we will prove that Canjar MAD families exist in most of the models of set theory. Using these ideas, we will also give alternative proofs of two theorems by Shelah: the consistency of $\mathfrak{b} < \mathfrak{s}$ and $\mathfrak{b} < \mathfrak{a}$. Finally we will study the ideals generated by branches. We will see that some of these ideals will help us to understand the difference between many combinatorial concepts related to Canjar filters. The results of this chapter are published in [GHMC17] and [GHMC14].

In chapter three we will review the differences between some of the most important concepts of porosity in the theory of metric spaces. We will see some relations between the concept of strong porosity and the Sacks forcing and we will use this relation to evaluate some of the cardinal invariants related to the ideal of strongly porous sets. We will also study some cardinal invariants closely related to Martin's Axiom and we will see that these cardinal invariants are closely related to the uniformity number of the cardinal invariants associated to the ideal of porous sets. The results of this chapter will appear on [GHMC].

In chapter four we will study a famous open problem in topology; the Michael space problem. The Michael space problem is featured in [HM07] and is concerned about the existence of a Lindelöf space such that its product with the irrational numbers is not Lindelöf. We will give a brief historical introduction to the problem and we will see its relation with some of the most classical cardinal invariants. Then we will introduce the concept of Michael ultrafilter, which is a concept that tries to relate the Michael space problem with some concepts related to the ultrapowers of the natural numbers. Using this new concept, we will find a relationship between p -points, q -points, selective ultrafilters and the Michael space problem. The results of this chapter are still in preparation.

At some times we will present a result without a proof. In those cases we try to reference the original author whenever it is possible. If for any reason that is not the case, we will give an alternative reference where the reader can find a proof of the result. For the convenience of the reader, at the end of this work, just before the references, we included an index where the notions we used in this work are presented, so the reader can easily find the page where such notions are defined.

Contents

Introduction	vii
Contents	ix
1 Infinitary Combinatorics and Topology	1
1.1 Topology	1
1.2 Ideals and Filters	6
1.3 Cardinal Invariants	9
1.4 Forcing	12
2 Canjar Filters	19
2.1 Introduction	19
2.2 Borel Canjar Filters	24
2.3 Canjar MAD families	28
2.4 The consistency of $\mathfrak{b} < \mathfrak{s}$ and $\mathfrak{b} < \mathfrak{a}$	36
2.5 Ideals generated by branches	44
2.6 Open Questions	49
3 Porous sets	51
3.1 Introduction	51
3.2 The Additivity and the Cofinality number.	58
3.3 Sacks forcing and anti-Sacks trees	60
3.4 The uniformity number	63
3.5 The covering number	74
3.6 Questions	75
4 The Michael Space Problem	77
4.1 Introduction	77
4.2 Michael Spaces and Cardinal Invariants	78
4.3 Michael Ultrafilters	84

4.4	Selectivity and Michael spaces.	92
4.5	Michael ultrafilters may not exist	95
	Index	101
	Bibliography	105

Chapter 1

Infinitary Combinatorics and Topology

The purpose of this chapter is to introduce the notation we will be using, the basic notions and the basic results to the reader. The reader should be accustomed to read basic concepts in topology and set theory. The theorems that are stated in this chapter do not include a proof. At the beginning of each section of this chapter, we have included some references so the reader can verify the results we stated in this chapter.

Most of our notation is standard between set theorists and topologists (we will usually follow the notation from [Kun80]). We will use the angled brackets \langle, \rangle to write out ordered pairs and we will use squared brackets or parenthesis $(,)$, $[,]$ to write down intervals in an ordered set (usually ω or \mathbb{R}).

1.1 Topology

Most of the results presented in this section can be found in [Eng77] and [Kec95].

Definition 1.1.1. *A topological space is an ordered pair $\langle X, \tau \rangle$, where X is a set (called the set of points) and τ is a collection of subsets of X (called a topology for X) satisfying the following properties:*

- $\emptyset, X \in \tau$,
- if $\mathcal{U} \subseteq \tau$, then $\bigcup \mathcal{U} \in \tau$,
- if $\mathcal{U} \subseteq \tau$ is finite, then $\bigcap \mathcal{U} \in \tau$.

Elements of τ are called *open sets* and the complement of an open set is a *closed set*. A subset $A \subseteq X$ of the set of points of a topological space is itself a topological space, where a set $U \subseteq A$ is open if and only if there is an open set V of X such that $U = A \cap V$. The examples that we are going to use in this work are mostly sets of real numbers: We will work with \mathbb{R} with the topology generated by the intervals, 2^ω and ω^ω with the product topology, that is the topology generated by the sets of the form $\langle t \rangle = \{f : t \subseteq f\}$ (the cone of t), where t is a finite partial function. Most of the time we will be dealing with subspaces of these topological spaces, thus we will often omit the definition of the topology. These topological spaces are also examples of metric spaces.

Definition 1.1.2. A metric space is an ordered pair $\langle X, \rho \rangle$, where X is a set and ρ is a function $\rho : X^2 \rightarrow [0, \infty)$ with the following properties:

- For all $x, y \in X$, $\rho(x, y) = 0$ if and only if $x = y$,
- for all $x, y \in X$, $\rho(x, y) = \rho(y, x)$,
- (the triangle inequality) for all $x, y, z \in X$, $\rho(x, y) + \rho(y, z) \geq \rho(x, z)$.

Given $x \in X$ and $\varepsilon > 0$ the set $B_\varepsilon(x) = \{y \in X : \rho(x, y) < \varepsilon\}$ is called the ball with center x and radius ε .

In a metric space, a set U is open if for all $x \in U$ there is $\varepsilon > 0$ such that $B_\varepsilon(x) \subseteq U$. It follows that the collection of open sets of a metric space X forms a topology for X . The euclidean metric in \mathbb{R} , $\rho(x, y) = |x - y|$, generates the topology of the intervals, and the product topology is generated by the metric $\rho(f, g) = \frac{1}{2^{\Delta(f, g)}}$, where $\Delta(f, g) = \min\{k \in \omega : f(k) \neq g(k)\}$ if $f \neq g$ and $\Delta(f, g) = 0$ if $f = g$. One of the main concepts we will study in this work is the notion of compactness.

Definition 1.1.3. Given a topological space X , a subset $K \subseteq X$ is said to be compact if every open cover of K (a collection of open sets whose union contains K) has a finite subcover (a finite subcollection of the open cover with the property that the union still covers K).

Another concept close to compactness is the concept of a Lindelöf space.

Definition 1.1.4. A subset $L \subseteq X$ from a topological space X is said to be Lindelöff if every open cover of L has a countable subcover.

In this work, we will be using mostly Polish spaces. A metric space is *Polish* if it is separable and completely metrizable. A topological space is *separable* if it has a countable dense subset (a set intersecting every open set). A metric space is completely metrizable if it is homeomorphic to a complete metric space (for example, the interval $(0, 1)$ is completely metrizable). The following is a notion that we will use frequently in this work.

Definition 1.1.5. Let X be a topological space. A subset $N \subseteq X$ is nowhere dense if for every open set U , there is an open set $V \neq \emptyset$ such that $V \subseteq U \cap (X \setminus N)$. A subset $M \subseteq X$ is meager if there is a collection N_0, N_1, N_2, \dots of nowhere dense sets such that $M \subseteq \bigcup_{i \in \omega} N_i$.

One of the most important results in the theory of complete metric spaces is the following

Theorem 1.1.1 (Baire Category Theorem). *If X is a complete metric space or a compact topological space, then X is not meager.*

In a great part of this work, we will be interested in studying the structure of the reals in any of its usual presentations: $2^\omega, \omega^\omega, \mathbb{R}, \dots$. We will be interested in studying the class of definable sets of the reals. In particular, we are interested in the structure of the Borel sets.

Definition 1.1.6. Given a set of reals X , the class of the Borel sets of X is the minimal σ -algebra (a collection of sets closed under complements and countable unions) containing the open sets of X . We will denote this class by $\text{Borel}(X)$.

The class $\text{Borel}(X)$ can be analyzed in a transfinite hierarchy of length ω_1 , this transfinite hierarchy is called *the Borel hierarchy*: In the lowest level we have the open sets and the closed sets, then we have the G_δ (countable intersections of open sets) and the F_σ sets (countable unions of closed sets), then the $G_{\delta\sigma}$ sets (countable unions of G_δ sets) and the $F_{\sigma\delta}$ sets (countable intersection of F_σ sets), and so on. Generally, these classes are denoted by $\Sigma_\alpha^0, \Pi_\alpha^0$, where Σ_1^0 is the class of open sets, Π_1^0 is

the class of closed sets, and if α is such that $1 < \alpha < \omega_1$,

$$\Sigma_\alpha^0 = \{\text{Countable unions of elements of } \bigcup_{\beta < \alpha} \Pi_\beta^0\}$$

and Π_α^0 is the collection of complements of Σ_α^0 . Therefore $\Sigma_2^0 = \{F_\sigma \text{ sets}\}$, $\Pi_2^0 = \{G_\delta \text{ sets}\}$, $\Sigma_3^0 = \{G_{\delta\sigma} \text{ sets}\}$, $\Pi_3^0 = \{F_{\sigma\delta} \text{ sets}\}$. It is easy to see that $\text{Borel}(X) = \bigcup_{\alpha < \omega_1} \Sigma_\alpha^0 = \bigcup_{\alpha < \omega_1} \Pi_\alpha^0$. Also, it is possible to show that these hierarchy classes are different from each other (see [Kec95]).

Another important combinatorial tool is the concept of a tree.

Definition 1.1.7. A tree on a set X is a subset $T \subseteq X^{<\omega}$ closed under initial segments (if $t \in T$ and $s \subseteq t$ then $s \in T$).

The elements of a tree are called *nodes*. The *stem* of a tree T , denoted by $\text{stem}(T)$ is the \subseteq -maximal node that is compatible with every node of T . A node $t \in T$ is a *splitting node* if there are different i, j such that both $t \frown i$ and $t \frown j$ are elements of T . A *pruned tree* is a tree without maximal nodes. In this work, we will be working mostly with pruned trees, so from now on, whenever we mention the notion of a tree, we mean a pruned tree. A branch of T is an element x of X such that, for every $n \in \omega$, $x \upharpoonright_n \in T$. We will denote the set of all branches of T by $[T]$.

For any set X , there is a natural metric on X^ω : if $f, g \in X^\omega$ with $f \neq g$, then $d(f, g) = \frac{1}{2^{\Delta(f, g)}}$, where $\Delta(f, g) = \min\{n \in \omega : f(n) \neq g(n)\}$. The following proposition is straightforward from the definition:

Proposition 1.1.1. For every pruned tree T on X , the set of branches of T is a non empty closed set on X^ω . Moreover, if $C \subseteq X^\omega$ is a non empty closed set, then there is a pruned tree T such that $C = [T]$.

In this work we will be dealing with the concept of an infinite game. Given any non-empty set X and a subset $A \subseteq X^\omega$, the *game* $G_X(A)$ is a two player game of perfect information of length ω such that each player sequentially plays elements from X and the first player wins if and only if the concatenation of all the elements played by the Player I is an element of A . We will be representing games using the following diagram:

I	$x_0 \in X$		$x_1 \in X$		$x_2 \in X$...
II		$y_0 \in X$		$y_1 \in X$		$y_2 \in X$...

The Player I wins if and only if $x_0 \hat{y}_0 x_1 \hat{y}_1 \dots \in A$.

The interesting thing about games are strategies: A *strategy for I* is a function $\sigma : X^{<\omega} \rightarrow X$. In other words, a strategy for I is a predefined way for the player I to play the game; for example, if the player II has played y_1, y_2 and y_3 in its first, second and third turn, respectively, then the player I will play $\sigma(\langle x_1, y_1, x_2, y_2, x_3, y_3 \rangle)$. A strategy σ for I is *winning* if for every $x \in X^\omega$, $\sigma(\emptyset) \hat{\sigma}(x(0)) \hat{\sigma}(\langle x(0), x(1) \rangle) \hat{\dots} \in A$. In other words, no matter what the player II plays, the player I will win if the player I follows the strategy σ .

In an analogous way, we define *strategy for II* and *winning strategy for II*. A game is said to be *determined* if one of the two players has a winning strategy.

Not all games are determined, take for example the following game: Let \mathcal{U} be a non-principal ultrafilter on ω .

I	$x_0 \in \omega$		$x_1 > y_0$		$x_2 > y_1$...
II		$y_0 \geq x_0$		$y_1 > x_1$...

The Player I wins if and only if $[0, y_0) \cup [x_1, y_1) \cup [x_2, y_2) \cup \dots \in \mathcal{U}$. Formally, we didn't give a game defined by the rules above. However, there is a natural set $A \subseteq \omega^\omega$ such that the game we just defined is $G_\omega(A)$ (this practice will be standard in this work).

We will show that this game is not determined: Let σ be any strategy for the player I, let $a = \sigma(\emptyset)$ and consider the following two sequences (which are defined recursively):

$$\begin{aligned} y_1 &= \langle a, \quad \sigma(\langle \sigma(a) \rangle), \quad \sigma(y_2 \upharpoonright 2), \quad \dots \\ y_2 &= \langle \sigma(\langle a \rangle), \quad \sigma(\langle a, \sigma(a) \rangle), \quad \sigma(y_1 \upharpoonright 3), \quad \dots \end{aligned}$$

It is easy to see that if the player II loses to the strategy σ using y_1 , then the player II wins to the strategy σ and, as a consequence, σ is not a winning strategy. In a similar way it is possible to show that there are no winning strategies for the player II.

The problem with the example above is that ultrafilters are non-definable objects. The situation for Borel sets is completely different: The most important theorem related to games is the Borel determinacy theorem, proved by D. Martin in [Mar75].

Theorem 1.1.2 (Martin theorem). *If A is a Borel set, then $G_X(A)$ is determined.*

Because of this theorem, Borel sets are thought to be well-behaved. There are some sets that are far from being Borel, for example, a *Bernstein set*, which is an uncountable set that intersects every uncountable closed set and its complement. Another example of non-Borel sets are *Luzin sets*, which are sets whose only meager subsets are its countable subsets. The existence of Luzin sets is independent from ZFC.

In this work we will also use some notions from measure theory. We will be using basic properties from the Lebesgue measure of \mathbb{R} and the product measures of 2^ω and ω^ω . We strongly recommend the reader to consult [Oxt13] to consult the definition of these measures.

1.2 Ideals and Filters

In mathematics, one way to represent the concept of smallness is by using the notion of an ideal. In a similar way, the concept of largeness is represented by using the notion of filter. These notions are very important in topology, analysis and set theory. An extensive survey in this topic can be found in [Hru11]. A good source of information regarding ideals on Polish spaces can be found in [Zap08].

Definition 1.2.1. *An ideal over a set X is a collection of subsets $\mathcal{I} \subseteq P(X)$ with the following properties:*

- $\emptyset \in \mathcal{I}, X \notin \mathcal{I}$,
- if $A, B \in \mathcal{I}$, then $A \cup B \in \mathcal{I}$,
- if $A \in \mathcal{I}$ and $B \subseteq A$, then $B \in \mathcal{I}$.
- for every $x \in X$, $\{x\} \in \mathcal{I}$.

A collection of subsets $\mathcal{F} \subseteq P(X)$ is a filter over X if $\{X \setminus A : A \in \mathcal{F}\}$ is an ideal over X .

Given an ideal \mathcal{I} , the *dual filter* of \mathcal{I} is $\mathcal{I}^* = \{A \subseteq X : X \setminus A \in \mathcal{I}\}$. The notion of dual ideal is defined in a similar way: Given a filter \mathcal{F} , the *dual*

ideal of \mathcal{F} is $\mathcal{F}^* = \{A \subseteq X : X \setminus A \in \mathcal{F}\}$. An ideal \mathcal{I} is *tall* if for every infinite $Y \subseteq X$ there is an infinite $I \in \mathcal{I}$ such that $I \subseteq Y$. Given an ideal \mathcal{I} , the collection of \mathcal{I} -positive sets are those sets who are not in the ideal, that is $\mathcal{I}^+ := \{A \subseteq \omega : A \notin \mathcal{I}\}$. If \mathcal{F} is a filter, then the set of \mathcal{F} -positive sets is $\mathcal{F}^+ := (\mathcal{F}^*)^+$.

An ideal \mathcal{I} is a σ -ideal if it is closed under countable unions of its elements. In this thesis, we will be working on ideals and filters over a countable set and with σ -ideals over a set of real numbers. Given a set X and a collection of subsets $\mathcal{A} \subseteq P(X)$, the *ideal generated by \mathcal{A}* is the smallest ideal containing \mathcal{A} (if it exists) and the *filter generated by \mathcal{A}* is the smallest filter containing \mathcal{A} (if it exists). Given an ideal (or a filter) \mathcal{I} and a subset $\mathcal{A} \subseteq \mathcal{I}$, it is said that \mathcal{A} is a *basis for \mathcal{I}* , if the ideal (or the filter) generated by \mathcal{A} is \mathcal{I} . Given a filter \mathcal{F} , the smallest cardinality of a basis for \mathcal{F} is denoted by $\chi(\mathcal{F})$. We will also use the analogous notions of basis for σ -ideals.

In set theory, there are several ways to compare ideals. The following are concepts that are used to compare ideals.

Definition 1.2.2. Let \mathcal{I}, \mathcal{J} be ideals over ω .

- (Katetov order) $\mathcal{I} \leq_K \mathcal{J}$ if there is a function $f : \omega \rightarrow \omega$ such that, for every $I \in \mathcal{I}$, $f^{-1}(I) \in \mathcal{J}$.
- (Rudin - Keisler order) $\mathcal{I} \leq_{RK} \mathcal{J}$ if there is a function $f : \omega \rightarrow \omega$ such that $I \in \mathcal{I}$ if and only if $f^{-1}(I) \in \mathcal{J}$.
- (Rudin - Blass order) $\mathcal{I} \leq_{RB} \mathcal{J}$ if there is a finite to one function $f : \omega \rightarrow \omega$ (that means that for every $n \in \omega$, $f(n)$ is finite) for every $I \in \mathcal{I}$ if and only $f^{-1}(I) \in \mathcal{J}$.

The notions for filters are analogous.

Ideals and filters over ω can be seen as subspaces of the Cantor set, so it makes sense to speak over the topological properties of these objects. An important notion that we are going to be using frequently in this work is the notion of F_σ -ideal. In [Maz91], Mazur gave a characterization for F_σ ideals. Before presenting this characterization, we will need the following notion.

Definition 1.2.3. A lower semicontinuous submeasure (lscsm) is a function $\mu : \mathcal{P}(\omega) \rightarrow [0, \infty]$ with the following properties: For every $A, B \subseteq \omega$

- $\mu(\emptyset) = 0$,
- $\mu(A \cup B) \leq \mu(A) + \mu(B)$,
- $\mu(A) = \lim_{n \rightarrow \infty} \mu(A \cap n$.

Given a lscsm μ , there is a natural ideal associated with μ , which is $\text{Fin}(\mu) := \{A : \mu(A) < \infty\}$. It is easy to see that these ideals are F_σ . It turns out that every F_σ ideal has this form.

Theorem 1.2.1 ([Maz91]). For every F_σ ideal \mathcal{I} there is a lscsm μ such that $\mathcal{I} = \text{Fin}(\mu)$.

An *Ultrafilter* is a filter which is maximal under \subseteq . An easy application of Zorn's Lemma (see [Kun80]) shows that ultrafilters exist, however none of them can be definable. The following are important notions of ultrafilters that we will use in this work.

Definition 1.2.4. An ultrafilter \mathcal{U} over ω is a

- *p-point* if for every $f : \omega \rightarrow \omega$ there is a $U \in \mathcal{U}$ such that either $f \upharpoonright_U$ is constant or for every $n \in \omega$, $f^{-1}(n) \cap U$ is finite,
- *q-point* for every finite to one $f : \omega \rightarrow \omega$ there is a $U \in \mathcal{U}$ such that for every $n \in \omega$, $f^{-1}(n) \cap U$ has at most one element,
- *selective ultrafilter* or *Ramsey ultrafilter* if for every $f : \omega \rightarrow \omega$ there is a $U \in \mathcal{U}$ such that either $f \upharpoonright_U$ is constant or for every $n \in \omega$, $f^{-1}(n) \cap U$ has at most one element (if it is p-point and q-point at the same time).

There is an equivalent statement for q-points in terms of interval partitions. An *interval partition* of ω is a partition $\{P_i : i \in \omega\}$ such that each P_i is an interval $[a, b)$ with $a, b \in \omega$. It is easy to see that an ultrafilter \mathcal{U} is a q-point if and only if for every interval partition $\{P_i : i \in \omega\}$ there is an $U \in \mathcal{U}$ such that for every $i \in \omega$, $P_i \cap U$ has at most one element.

Observe that any ultrafilter \leq_{RK} -below (and thus \leq_{RB} -below) a p-point is itself a p-point and that any ultrafilter \leq_{RB} -below a q-point is

a q -point. It can be proved (see for example [BJ95]) that selective ultrafilters are minimal under the Rudin-Keisler order. It is well-known that the existence of these objects is independent from ZFC, however all these objects exists under the continuum hypothesis.

1.3 Cardinal Invariants

George Cantor proved that the cardinality of the real line (which it is usually denoted by \mathfrak{c}) is strictly greater than the cardinality of the natural numbers. This important result classify the subsets of reals into two classes: the class of countable sets and the class of uncountable sets. This classification turned out to be useful in many branches of mathematics, including analysis and topology. In this work, we will focus on studying the cardinal characteristics of structures connected with the real line.

A cardinal invariant can be thought as a function that returns cardinal numbers. We will be working mostly on the context of set theory so the value of a cardinal invariant will depend on the theory we are working in. We will not give a formal definition of a cardinal invariant (one can be found in [Voj93]) as we will only work with particular examples. Every single cardinal invariant mentioned in this work can be restated as a particular case of the definition found in the work cited above. We will only use the formal definition briefly in a theorem in the second chapter. We will briefly enlist some of the cardinal invariants we will be using in this work.

Let $A, B \in [\omega]^\omega$, then A is *almost contained* in B ($A \subseteq^* B$) if $B \setminus A$ is finite. If $A \subseteq^* B$ and $B \subseteq^* A$, then A is *almost equal to* B ($A =^* B$). A family of sets $\mathcal{F} \subseteq [\omega]^\omega$ is a *filter basis* (resp. *ultrafilter basis*) if the set $\{A \in [\omega]^\omega : \exists F \in \mathcal{F} (F \subseteq A)\}$ is a filter (resp. ultrafilter). Given a family of sets $\mathcal{F} \subseteq [\omega]^\omega$ and a set $P \in [\omega]^\omega$, the set P is a *pseudointersection* of the family \mathcal{F} if for every $F \in \mathcal{F}$, P is almost contained in F . Clearly every ultrafilter basis does not have pseudointersections. The following are the classical cardinal invariants related to filter basis, the *pseudointersection number* and the *ultrafilter number*.

$$\mathfrak{p} = \min\{|\mathcal{F}| : \mathcal{F} \text{ is a filter basis without a pseudointersection}\},$$

$$\mathfrak{u} = \min\{|\mathcal{F}| : \mathcal{F} \text{ is an ultrafilter basis}\}.$$

Let $\mathcal{A} \subseteq [\omega]^\omega$ be an infinite family of sets, then \mathcal{A} is an *almost disjoint family* if for every $A, B \in \mathcal{A}$, if $A \neq B$ then the set $A \cap B$ is finite. An almost disjoint family \mathcal{A} is a *maximal almost disjoint family* (a *MAD family*) if for every $B \in [\omega]^\omega \setminus \mathcal{A}$, there is $A \in \mathcal{A}$ such that $A \cap B$ is infinite. The following is the classical cardinal invariant related to MAD families, the *almost disjoint family number*.

$$\mathfrak{a} = \min\{|\mathcal{A}| : \mathcal{A} \text{ is a MAD family}\}.$$

Let $f, g \in \omega^\omega$ then $f \leq^* g$ if the set $\{n \in \omega : f(n) > g(n)\}$ is finite. A family $\mathcal{F} \subseteq \omega^\omega$ is *unbounded* if for every $g \in \omega^\omega$ there is an $f \in \mathcal{F}$ such that $f \not\leq^* g$. A family $\mathcal{F} \subseteq \omega^\omega$ is *dominating* if for every $g \in \omega^\omega$ there is an $f \in \mathcal{F}$ such that $g \leq^* f$. Clearly every dominating family is an unbounded family. The following are the classical cardinal invariants related to family of functions, the *boundedness number* and the *dominating number*.

$$\mathfrak{b} = \min\{|\mathcal{F}| : \mathcal{F} \text{ is unbounded}\},$$

$$\mathfrak{d} = \min\{|\mathcal{F}| : \mathcal{F} \text{ is dominating}\}.$$

Let $X, Y \in [\omega]^\omega$, then X *splits* Y if both $X \cap Y$ and $Y \setminus X$ are infinite sets. A family $\mathcal{S} \subseteq [\omega]^\omega$ is a *splitting family* if for every $Y \in [\omega]^\omega$ there is an $X \in \mathcal{S}$ such that X splits Y . A family $\mathcal{R} \subseteq [\omega]^\omega$ is a *reaping family* if no $X \in [\omega]^\omega$ splits every member of \mathcal{R} . The following are the classical cardinal invariants related to splitting families, the *splitting number* and the *reaping number*.

$$\mathfrak{s} = \min\{|\mathcal{S}| : \mathcal{S} \text{ is a splitting family}\},$$

$$\mathfrak{r} = \min\{|\mathcal{R}| : \mathcal{R} \text{ is a reaping family}\}.$$

A family of sets $\mathcal{D} \subseteq [\omega]^\omega$ is said to be *dense* if for every $A \in [\omega]^\omega$ there is a set $B \in \mathcal{D}$ such that $B \subseteq^* A$. The *distributivity number* is the following cardinal invariant.

$$\mathfrak{h} = \min\{|\mathcal{E}| : \mathcal{E} \text{ is a family of dense sets such that } \bigcap \mathcal{E} = \emptyset\}$$

In this work we would not include the following cardinal invariant, but it is here for the sake of completeness. A family of sets $\mathcal{I} \subseteq [\omega]^\omega$ is said to be *independent* if for every finite collection $F_0 \subseteq \mathcal{I}$ and every finite collection $F_1 \subseteq \mathcal{I} \setminus F_0$, $\bigcap F_0 \cap \bigcap F_1^c$ is infinite, where $F_1^c = \{\omega \setminus A : A \in F_1\}$. The *independence number* is the following cardinal invariant.

$$i = \min\{|\mathcal{I}| : \mathcal{I} \text{ is a } \subseteq\text{-maximal independent family}\}$$

The relation between these cardinal invariants can be summarized in the following diagram, which is known in the literature as the Van Doven's diagram [Dou84]. *Van Doven's diagram*

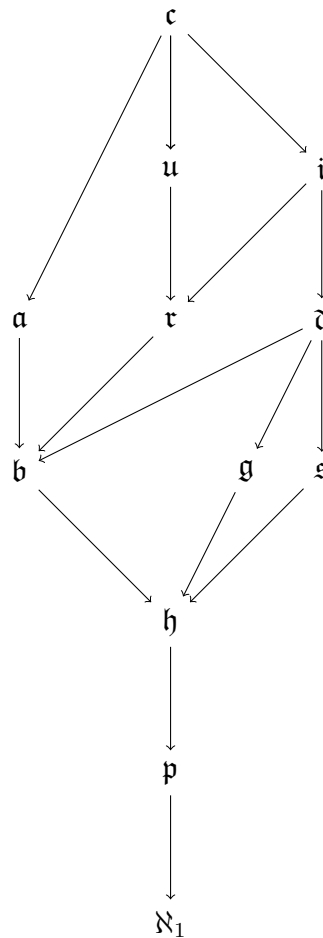

FIGURE 1.1: Van Doven's diagram

Given a σ -ideal \mathcal{I} over an uncountable set of real numbers \mathcal{R} , the following are the cardinal invariants related to the ideal \mathcal{I} :

1. $\text{add}(\mathcal{I}) = \min\{A \subseteq \mathcal{I} : \bigcup A \notin \mathcal{I}\},$
2. $\text{cov}(\mathcal{I}) = \min\{A \subseteq \mathcal{I} : \bigcup A = \mathcal{R}\},$
3. $\text{non}(\mathcal{I}) = \min\{B \subseteq \mathcal{R} : B \notin \mathcal{I}\},$
4. $\text{cof}(\mathcal{I}) = \min\{A \subseteq \mathcal{I} : \forall b \in \mathcal{I} (\exists a \in A (b \subseteq a))\}.$

It is easy to see that $\aleph_0 < \text{add}(\mathcal{I}) \leq \min\{\text{non}(\mathcal{I}), \text{cov}(\mathcal{I})\} \leq \max\{\text{non}(\mathcal{I}), \text{cov}(\mathcal{I})\} \leq \text{cof}(\mathcal{I})$ and, in the case that \mathcal{I} is σ -generated by Borel sets, $\text{cof}(\mathcal{I}) \leq \mathfrak{c}$. The σ -ideals of meager and null sets plays an important role in this work and it turns out there are important relations between the cardinal invariants of these ideals. The relations between these ideals can be summarized in the Cichoń's diagram.

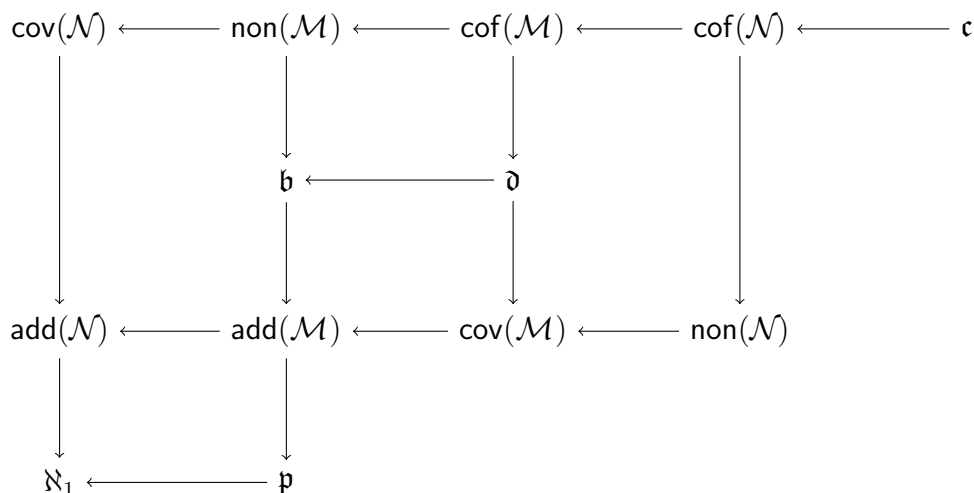

FIGURE 1.2: Cichoń's diagram

There is a class of cardinal invariants we still need to talk about which is related to the concept of forcing.

1.4 Forcing

In 1963, Paul Cohen ([Coh63] [Coh64]) proved the independence of the continuum hypothesis and the axiom of choice. He did that using a technique called forcing, which consist of adding a generic filter to a model of set theory. The reader can consult [Kun80] for an introduction to this topic. Most of the consistency proofs that are stated in this section can

be found in [BJ95]. We also will be working with the concept of elementary submodels, the reader can consult [Dow88] for an introduction to this topic.

A *forcing* (which is also known as a *separative partial order*) is a partial order $\langle \mathbb{P}, \leq \rangle$ such that for every $p \in \mathbb{P}$ there are $r, s \leq p$ such that there is no $p' \in \mathbb{P}$ such that p is smaller than both r and s . We will always assume that our forcings have a maximal element 1. Usually, when we are talking about a particular forcing or a particular partial order, we will not mention the order itself if it is clear from the context. In this work, we will be using forcing downwards (in [Kun80] it is done downwards and in [BJ95] it is done upwards), so the stronger conditions are the smaller ones.

Given a partial order \mathbb{P} , a *filter* is a subset $F \subseteq \mathbb{P}$ such that

- $1 \in F$
- if $p, q \in F$ then there is $r \in F$ such that r is stronger than both p and q
- if $p \in F$ and p is stronger than q , then $q \in F$.

Given a partial order \mathbb{P} , we will say that a subset $D \subseteq \mathbb{P}$ is *dense* if for every $p \in \mathbb{P}$ there is a $p' \in D$ such that $p' \leq p$. Given a forcing \mathbb{P} and a collection of dense sets \mathcal{D} we will say that a filter G is *generic for \mathcal{D}* if G intersects every dense set from \mathcal{D} . Generic filters usually do not exist, but there are some cases when they do.

Lemma 1.4.1 (Rasiowa–Sikorski). *If \mathcal{D} is a countable collection of dense sets of a given forcing, then there is a generic filter for \mathcal{D}*

Generic filters for countable collections of dense sets always exist and they may exist for a larger collection of dense sets. Given a property of forcings φ and a cardinal κ , the statement $\mathbf{MA}_\kappa(\varphi)$ is the following: $\mathbf{MA}_\kappa(\varphi) :=$ for every forcing satisfying the property φ and for every collection of dense sets \mathcal{D} such that $|\mathcal{D}| = \kappa$ there is a generic filter for \mathcal{D} . Two of the most important properties of forcings are the c.c.c. property and the σ -centered property. A forcing is *σ -centered* if it can be written as a countable union of filters. A forcing has the *c.c.c.* (*countable chain*

condition) if it does not have uncountable antichains (A subset A of a forcing \mathbb{P} is an *antichain* if for every different $p, q \in A$, there is no $r \in \mathbb{P}$ stronger than both p and q). Observe that every σ -centered forcing have the c.c.c. property. The following are the Martin numbers associated to c.c.c. forcings and σ -centered forcings.

$$\mathfrak{m} = \min\{\kappa : \text{MA}_\kappa(\text{has the c.c.c. property}) \text{ fails}\}$$

$$\mathfrak{m}_{\sigma\text{-centered}} = \min\{\kappa : \text{MA}_\kappa(\text{is } \sigma\text{-centered}) \text{ fails}\}.$$

A famous theorem by Bell [Bel81] states that $\mathfrak{p} = \mathfrak{m}_{\sigma\text{-centered}}$. It is also well known that \mathfrak{m} is smaller than every cardinal invariant in both the Van Doven's and the Cichoń's diagrams. The *Martin's Axiom* (denoted by *MA*) is the statement that $\mathfrak{m} = \mathfrak{c}$. It can be shown that this axiom is compatible with the negation of the continuum hypothesis.

In this work we will be dealing with concepts of forcing theory that are simply too complicated to explain in just a few pages (proper forcing, iteration with countable support, some preservation theorems among other concepts), so we encourage the reader to consult [BJ95] to know more about these notions, just be aware that the authors of [BJ95] use forcing upwards. We will now give examples of some forcing notions that we will be using in this work:

The *Cohen forcing* is the set of finite functions $2^{<\omega}$ ordered by inclusion: largest functions are the stronger ones. Any countable forcing is forcing equivalent to Cohen's forcing.

The *Random forcing* is the set of the Borel subsets of positive measure of \mathbb{R} , ordered by reverse inclusion: smaller sets are the stronger ones. It is possible to change \mathbb{R} for 2^ω or ω^ω and we will still get equivalent forcing notions.

The *Sacks forcing* is the set of all pruned trees $T \subseteq 2^{<\omega}$ such that, for each $t \in T$ there are $t', t'' \in T$ such that t' and t'' are incompatible functions and t is extended by both t' and t'' . The order of this forcing is the reverse inclusion: smaller trees are the stronger conditions. Consult [Zap08] for equivalent presentations of this forcing.

The *Miller forcing* (also called the superperfect tree forcing) is the set of all trees $T \subseteq \omega^{<\omega}$ with the following properties:

- for every $t \in T$, there is a $s \in T$ such that s is a splitting node and $t \subseteq s$,
- if $s \in T$ is a splitting node, then s splits infinitely.

The order of this forcing is the reverse inclusion: smaller trees are the stronger conditions.

The *Laver forcing* is the set of all trees $T \subseteq \omega^{<\omega}$ with the following properties:

- $\text{stem}(T)$ exists
- for every $t \in T$, if $\text{stem}(T) \subsetneq t$ then t is a splitting node.
- if $t \in T$ is a splitting node, then t splits infinitely.

The order of this forcing is the reverse inclusion: smaller trees are the stronger conditions.

The *Mathias forcing* is the set of all pairs $\langle s, A \rangle$ such that $s \in [\omega]^{<\omega}$ and $A \in [\omega \setminus \max s]^\omega$. A condition $\langle s, A \rangle$ is stronger than a condition $\langle s', A' \rangle$ if and only if $s' \subseteq s$, $A \subseteq A'$ and $s \setminus s' \subseteq A'$.

The *Hechler forcing* is the set of all pairs $\langle s, f \rangle$ such that s is a partial finite function from ω to ω (this will be denoted by $s; \omega \rightarrow \omega$) and $f \in \omega^\omega$. A condition $\langle s, f \rangle$ is stronger than a condition $\langle s', f' \rangle$ if and only if $s' \subseteq s$, $f' \subseteq f$ and if $n \in \text{dom}(s \setminus s')$, then $s(n) \geq f'(n)$.

It turns out that each one of these forcing notions is proper, so it makes sense to consider the countable support iteration of length ω_2 of each one of these forcings to get different models of set theory. The Cohen model is obtained by forcing with the countable support iteration of length ω_2 of the Cohen forcing, the random model is obtained by forcing with the countable support iteration of length ω_2 of the random forcing and so on. In the following tables, we summarize the behavior of the cardinal invariants that we mentioned before in each of these models.

To finish this chapter, we will introduce the reader to a certain class of real numbers that are closely related to forcing and some of the cardinal invariants we defined above.

Definition 1.4.1. *Let M, N be models of set theory such that $M \subseteq N$. Then $x \in N \cap \omega^\omega$ is*

	\mathfrak{p}	\mathfrak{h}	\mathfrak{b}	\mathfrak{s}	\mathfrak{g}	\mathfrak{r}	\mathfrak{a}	\mathfrak{d}	\mathfrak{u}	\mathfrak{i}
Cohen model	\aleph_1	\aleph_1	\aleph_1	\aleph_1	\aleph_1	\mathfrak{c}	\aleph_1	\mathfrak{c}	\mathfrak{c}	\mathfrak{c}
Random model	\aleph_1	\aleph_1	\aleph_1	\aleph_1	\aleph_1	\mathfrak{c}	\aleph_1	\aleph_1	\mathfrak{c}	\mathfrak{c}
Sacks model	\aleph_1	\aleph_1	\aleph_1	\aleph_1	\aleph_1	\aleph_1	\aleph_1	\aleph_1	\aleph_1	\aleph_1
Miller model	\aleph_1	\aleph_1	\aleph_1	\aleph_1	\mathfrak{c}	\aleph_1	\aleph_1	\mathfrak{c}	\aleph_1	\mathfrak{c}
Laver model	\aleph_1	\aleph_1	\mathfrak{c}	\aleph_1	\mathfrak{c}	\mathfrak{c}	\mathfrak{c}	\mathfrak{c}	\mathfrak{c}	\mathfrak{c}
Mathias model	\aleph_1	\mathfrak{c}	\mathfrak{c}	\mathfrak{c}	\mathfrak{c}	\mathfrak{c}	\mathfrak{c}	\mathfrak{c}	\mathfrak{c}	\mathfrak{c}
Hechler model	\aleph_1	\aleph_1	\mathfrak{c}	\aleph_1	\aleph_1	\mathfrak{c}	\mathfrak{c}	\mathfrak{c}	\mathfrak{c}	\mathfrak{c}

TABLE 1.1: Van Doven's cardinals in classical models

	$\text{add}(\mathcal{M})$	$\text{cov}(\mathcal{M})$	$\text{non}(\mathcal{M})$	$\text{cof}(\mathcal{M})$
Cohen model	\aleph_1	\mathfrak{c}	\aleph_1	\mathfrak{c}
Random model	\aleph_1	\aleph_1	\mathfrak{c}	\mathfrak{c}
Sacks model	\aleph_1	\aleph_1	\aleph_1	\aleph_1
Miller model	\aleph_1	\aleph_1	\aleph_1	\mathfrak{c}
Laver model	\aleph_1	\aleph_1	\mathfrak{c}	\mathfrak{c}
Mathias model	\aleph_1	\aleph_1	\mathfrak{c}	\mathfrak{c}
Hechler model	\mathfrak{c}	\mathfrak{c}	\mathfrak{c}	\mathfrak{c}

TABLE 1.2: Cardinal invariants of \mathcal{M} in classical models

	$\text{add}(\mathcal{N})$	$\text{cov}(\mathcal{N})$	$\text{non}(\mathcal{N})$	$\text{cof}(\mathcal{N})$
Cohen model	\aleph_1	\aleph_1	\mathfrak{c}	\mathfrak{c}
Random model	\aleph_1	\mathfrak{c}	\aleph_1	\mathfrak{c}
Sacks model	\aleph_1	\aleph_1	\aleph_1	\aleph_1
Miller model	\aleph_1	\aleph_1	\aleph_1	\mathfrak{c}
Laver model	\aleph_1	\aleph_1	\aleph_1	\mathfrak{c}
Mathias model	\aleph_1	\aleph_1	\mathfrak{c}	\mathfrak{c}
Hechler model	\aleph_1	\aleph_1	\mathfrak{c}	\mathfrak{c}

TABLE 1.3: Cardinal invariants of \mathcal{N} in classical models

- *a Cohen real over M if x is not in any meager set coded in M ,*
- *a Random real over M if x is not in any set of measure zero coded in M ,*
- *an unbounded real over M if no real from M bounds x ,*
- *a dominating real over M if x bounds every real from M .*

From the tables above we can deduce that, for example, Cohen and Hechler are the only forcings we listed above that adds a Cohen real. An interesting fact about Cohen real is that Cohen real are always added in limit stages of a finite support iteration of any nontrivial forcing.

Chapter 2

Canjar Filters

The results of this chapter are published in [GHMC17] and [GHMC14].

2.1 Introduction

One of the notions studied in combinatorial set theory is the concept of diagonalization of filters. A forcing notion \mathbb{P} *diagonalizes a filter* \mathcal{F} if \mathbb{P} adds a pseudo-intersection to \mathcal{F} . Given a filter \mathcal{F} , there are many forcing notions that diagonalize it. One of them is the *Laver forcing relative to \mathcal{F}* , denoted by $\mathbb{L}(\mathcal{F})$, which is the partial order of all pruned trees T such that they have a stem and the set of successors of every node below the stem forms a member of \mathcal{F} . The order of this forcing is the inclusion; stronger conditions are the smaller ones. There is also the Mathias forcing relative to \mathcal{F} , which is the notion we are going to work on in this chapter.

Definition 2.1.1. *The Mathias forcing relative to \mathcal{F} , denoted by $\mathbb{M}(\mathcal{F})$, is the set of all pairs $\langle s, F \rangle$ such that $s \in [\omega]^{<\omega}$ and $F \in \mathcal{F}$. The order is defined as $\langle s, F \rangle \leq \langle s', F' \rangle$ if and only if s' is an initial segment of s , $s \setminus s' \subseteq F'$ and $F \subseteq F'$.*

Depending on the filter \mathcal{F} , the forcings $\mathbb{M}(\mathcal{F})$ and $\mathbb{L}(\mathcal{F})$ could represent equivalent forcing notions. For example, if \mathcal{F} is a selective ultrafilter, then the application $i : \mathbb{M}(\mathcal{F}) \rightarrow \mathbb{L}(\mathcal{F})$ given by $i(\langle s, F \rangle) = T_{\langle s, F \rangle}$, where $T_{\langle s, F \rangle}$ is a tree such that its stem is $l(s)$ ($l : [\omega]^{<\omega} \rightarrow \omega^{<\omega}$ is an order preserving isomorphism) and every node below the stem branches in F , is a dense embedding and therefore $\mathbb{M}(\mathcal{F})$ is forcing equivalent to $\mathbb{L}(\mathcal{F})$. In general, the forcings $\mathbb{M}(\mathcal{F})$ and $\mathbb{L}(\mathcal{F})$ are not isomorphic. The

generic real of $\mathbb{L}(\mathcal{F})$ (the union of the stems of the trees in a generic filter) is always a dominating real. This is not necessarily the case for $\mathbb{M}(\mathcal{F})$. For example, if \mathcal{F} is the Frechét filter (the filter consisting of the complements of finite sets), then $\mathbb{M}(\mathcal{F})$ is a countable partial order, and therefore it is forcing equivalent to the Cohen forcing (hence it does not add dominating reals). The first example of an ultrafilter \mathcal{U} such that $\mathbb{M}(\mathcal{U})$ does not add dominating reals was given by Canjar (see [Can88]). Under $\mathfrak{d} = \mathfrak{c}$, Canjar constructed an ultrafilter whose associated Mathias forcing does not add a dominating real. This motivated the following notion.

Definition 2.1.2. *Given a filter \mathcal{F} , we say that \mathcal{F} is a Canjar filter if $\mathbb{M}(\mathcal{F})$ does not add a dominating real. An ideal is a Canjar ideal if its dual filter is a Canjar filter.*

Canjar filters have been investigated in [HH] and [BHV13]. In this chapter we will continue with that line of research.

In [HH] the authors found a combinatorial reformulation of being Canjar: Given a countable set X , we denote by $\text{Fin}(X)$ as the set of all non-empty finite subsets of X . If \mathcal{I} is an ideal on X , the ideal $\mathcal{I}^{<\omega}$ is defined as the set of all $A \subseteq \text{Fin}(X)$ such that there is $B \in \mathcal{I}$ with the property that $a \cap B \neq \emptyset$ for all $a \in A$. If \mathcal{F} is a filter on X , the filter $\mathcal{F}^{<\omega}$ is the dual filter of $(\mathcal{F}^*)^{<\omega}$, that is, the filter generated by the sets of the form $\text{Fin}(F)$, with $F \in \mathcal{F}$. Naturally, the positive sets of $(\mathcal{F})^{<\omega}$ are all the sets $A \subseteq \text{Fin}(X)$ such that for every $F \in \mathcal{F}$, there is $s \in A$ with $s \subseteq F$. We will need the following notion:

Definition 2.1.3. *Recall that a filter \mathcal{F} is a P^+ -filter if every decreasing sequence of positive sets has a positive pseudo-intersection. An ideal is a P^+ -ideal if its dual filter is a P^+ -filter.*

The characterization of Hrušák and Minami is the following.

Proposition 2.1.1 ([HH]). *An \mathcal{I} is a Canjar ideal if and only if $\mathcal{I}^{<\omega}$ is a P^+ -ideal.*

Proof. (\Rightarrow). Suppose that \mathcal{I} is Canjar, we will see that $\mathcal{I}^{<\omega}$ is a P^+ -ideal. Let \mathcal{F} be its dual filter and let $\{X_n : n \in \omega\}$ be a decreasing sequence of $F^{<\omega}$ positive sets and let $G \subseteq \mathbb{M}(\mathcal{F})$ be a generic filter. Working in

$V[G]$ let $m_{gen} = \bigcup \{s \in [\omega]^{<\omega} : \exists F \in \mathcal{F} (\langle s, F \rangle \in G)\}$. By genericity $\text{Fin}(m_{gen})$ intersects every X_m infinitely, therefore, in $V[G]$, it is possible to define $g : \omega \rightarrow \omega$ with the property that $(m_{gen} \setminus n) \cap g(n)$ contains a member of X_n . Now, using that \mathcal{I} is Canjar, we can find an $f \in \omega^\omega$ such that $\mathbb{M}(\mathcal{F}) \Vdash "f \not\leq \dot{g}"$. Define $X = \bigcup_{n \in \omega} (Y_n \cap \mathcal{P}(f(n)))$. Clearly X is a pseudo-intersection of $\{X_n : n \in \omega\}$, we have to show that X is $F^{<\omega}$ positive: Let $F \in \mathcal{F}$, we will find $s \subseteq F$ such that $s \in X$. Pick a condition $\langle t, G \cap F \rangle$ and $n \in \omega$ such that $\langle t, G \cap F \rangle \Vdash "m_{gen} \setminus n \subseteq F"$. Finally, pick a stronger condition $\langle t \cup s, G' \rangle \leq \langle t, G \rangle$ and $k > n$ such that $\langle t \cup s, G' \rangle \Vdash "f(k) \geq \dot{g}(k)"$. It follows that $s \in X$.

(\Leftarrow). Suppose that \mathcal{I} is not Canjar, we will see that $\mathcal{I}^{<\omega}$ is not a P^+ -ideal. Let \mathcal{F} be its dual filter and let \dot{g} be an $\mathbb{M}(\mathcal{F})$ -name of a dominating function. For each $f \in \omega^\omega$ pick $\langle s_f, F_f \rangle \in \mathbb{M}(\mathcal{F})$ and $n_f \in \omega$ such that

$$\langle s_f, F_f \rangle \Vdash "\forall n \geq n_f (f(n) \leq \dot{g}(n))".$$

Choose $s \in \omega^{<\omega}$, $n \in \omega$ and $\mathcal{D} \subseteq \omega^\omega$ such that \mathcal{D} is a dominating family and for every $f \in \mathcal{D}$, $s_f = s$ and $n_f = n$. For each $m \in \omega$, let

$$X_m = \{t \in [\omega \setminus s]^{<\omega} : \exists F \in \mathcal{F} (\langle t, F \rangle \text{ knows the value of } \dot{g}(0), \dots, \dot{g}(m))$$

$$\text{and } \langle s \cup t, F \rangle \Vdash "\dot{g}(m) < \max(t)"\}.$$

It is easy to see that $\{X_m : m \in \omega\}$ is a decreasing sequence of sets. If $F \in \mathcal{F}$, then it is possible to find a $t \in [\omega \setminus s]^\omega$ and $F' \in \mathcal{F}$ such that $F' \subseteq F$ and $\langle s \cup t, F' \rangle \Vdash "\dot{g}(m) < \max(t)"$, so therefore each X_m is an $\mathcal{F}^{<\omega}$ positive set. We will show that no pseudo-intersection can be positive: Suppose this is not the case and let X be a positive pseudo-intersection of $\{X_n : n \in \omega\}$. Note that, for each $k \in \omega$, $X \cap (X_k \setminus X_{k+1})$ is finite, so let $f(k) = (\max \bigcup (X \cap (X_k \setminus X_{k+1}))) + 1$ and let $h \in \mathcal{D}$ and $m > n_h$ be such that $h(i) \geq f(i)$ for every $i > m$. Choose $k > m$ such that $X_k \setminus X_{k+1} \neq \emptyset$. It follows that

$$\langle s, F_h \rangle \Vdash "h(k) \leq \dot{g}(k)".$$

Observe that $X \cap X_k$ is positive, therefore there exist $t \in X \cap X_k$ such that $t \subseteq F_h$, and therefore

$$\langle s \cup t, F_h \setminus t \rangle \Vdash "h(k) \leq \dot{g}(k)",$$

however this contradicts the fact that $f(k) > \max(t)$ for $t \in X_k$. \square

Using this characterization, it follows easily that the existence of Canjar ultrafilters implies the existence of p -points. As a consequence, there are models with no Canjar ultrafilters.

We will now aim to prove the original result of Canjar. Before that, we will need the following notion: Given a subset $A \subseteq \text{Fin}$, we denote by $\mathcal{C}(A)$ as the set of all $X \subseteq \omega$ such that $a \cap X \neq \emptyset$ for all $a \in A$. The following are basic properties of $\mathcal{C}(A)$.

- Lemma 2.1.1.** 1. If $A \subseteq \text{Fin}$, then $\mathcal{C}(A)$ is a compact set, and if $A \in (\mathcal{I}^{<\omega})^+$ then $\mathcal{C}(A) \subseteq \mathcal{I}^+$.
2. If \mathcal{C} is compact and $X \subseteq \omega$ intersects every element of \mathcal{C} , then there is $F \in [X]^{<\omega}$ such that F intersects every element of \mathcal{C} .
3. If $\mathcal{C}_1, \dots, \mathcal{C}_n$ are compact, then $\mathcal{D} = \{A_1 \cap \dots \cap A_n : \forall i \in \omega A_i \in \mathcal{C}_i\}$ is compact.

Proof. (1). It is straightforward to prove that $\mathcal{C}(A) \subseteq \mathcal{P}(\omega)$ is closed and therefore $\mathcal{C}(A)$ is compact. If $A \in (\mathcal{I}^{<\omega})^+$ then, by definition of $\mathcal{I}^{<\omega}$, $\mathcal{C}(A) \subseteq \mathcal{I}^+$. (2). $\{\{A \subseteq \omega : x \in A\} : x \in X\}$ is an open cover for \mathcal{C} . (3). The function $f : \mathcal{C}_1 \times \dots \times \mathcal{C}_n \rightarrow \mathcal{P}(\omega)$ defined by $f(\langle A_1, \dots, A_n \rangle) = A_1 \cap \dots \cap A_n$ is continuous. \square

We will make use of the following technical lemma.

Lemma 2.1.2. Let \mathcal{F} be a filter, $X \subseteq \text{Fin}$ such that $\mathcal{C}(X) \subseteq \mathcal{F}$ and let \mathcal{D} be a compact set with the property that $\mathcal{D} \subseteq \mathcal{F}$. Then, for every $n \in \omega$, there is $S \in [X]^{<\omega}$ such that, if $A_0, \dots, A_n \in \mathcal{C}(S)$ and $F \in \mathcal{D}$, then $A_0 \cap \dots \cap A_n \cap F \neq \emptyset$.

Proof. Given $s \in X$ define $K(s)$ as the set of all $\langle A_0, \dots, A_n \rangle \in \mathcal{C}(s)^{n+1}$ such that there is $F \in \mathcal{D}$ with $A_0 \cap \dots \cap A_n \cap F = \emptyset$. We will show that $K(s)$ is closed: Let $\langle A_0, \dots, A_n \rangle \notin K(s)$, and let $A = \bigcap_{j \leq n} A_j$, then, by (2) of the previous lemma, there is a finite set s of A such that s intersects

every element of \mathcal{D} . This finite set defines a neighborhood of $\langle A_0, \dots, A_n \rangle$ disjoint with $K(s)$. As a consequence, $K(s)$ is compact for each $s \in X$. Now note that if $\langle A_0, \dots, A_n \rangle \in \bigcap_{s \in X} K(s)$ then $A_0, \dots, A_n \in \mathcal{C}(X) \subseteq \mathcal{F}$ and there would be $F \in \mathcal{D} \subseteq \mathcal{F}$ such that $A_0 \cap \dots \cap A_n \cap F = \emptyset$ which contradicts the fact that \mathcal{F} is a filter. Since the $K(s)$ are compact and $\bigcap_{s \in X} K(s) = \emptyset$, then there must be an $S \in [F]^{<\omega}$ such that $\bigcap_{s \in S} K(s) = \emptyset$. This is the set we are looking for. \square

Now we are ready to prove the theorem of Canjar. We will be using the characterization of [HH] that we proved above.

Proposition 2.1.2 ([Can88]). *If $\mathfrak{d} = \mathfrak{c}$ then there is a Canjar ultrafilter.*

Proof. Let $\{\vec{X}_\alpha \mid \alpha \in \mathfrak{c}\}$ be an enumeration of all decreasing sequences of subsets of $[\omega]^{<\omega}$. Recursively, we will construct an increasing sequence of filters $\langle \mathcal{U}_\alpha \mid \alpha \in \mathfrak{c} \rangle$ such that for all $\alpha < \mathfrak{c}$,

1. \mathcal{U}_α is the union of less than \mathfrak{d} compact sets,
2. either \vec{X}_α is not a sequence of $(\mathcal{U}_{\alpha+1})^{<\omega}$ positive sets or they have a pseudo-intersection P such that $\mathcal{C}(P) \subseteq \mathcal{U}_{\alpha+1}$.

We begin by setting \mathcal{U}_0 as the Frechét filter and we take the union at limit stages. Assume we have already constructed \mathcal{U}_α , we will see how to construct $\mathcal{U}_{\alpha+1}$. In the case that $\vec{X}_\alpha = \langle X_n \mid n \in \omega \rangle$ is not a sequence of $(\mathcal{U}_\alpha)^{<\omega}$ positive sets, let $\mathcal{U}_{\alpha+1} = \mathcal{U}_\alpha$. In this case all the hypothesis are trivially fulfilled.

We will assume that each $X_n \in (\mathcal{U}_\alpha^{<\omega})^+$. It follows from the Lemma 3 that $\mathcal{C}(X_n) \subseteq (\mathcal{U}_\alpha)^+$. We will find a compact set \mathcal{D} such that $\mathcal{U}_\alpha \cup \mathcal{D}$ generates a filter:

In case there is $n \in \omega$ such that $\mathcal{C}(X_n)$ is not contained in \mathcal{U}_α , we choose $Y \in \mathcal{C}(X_n) - \mathcal{U}_\alpha$ and define $\mathcal{D} = \{\omega - Y\}$. Let $\mathcal{U}_{\alpha+1} = \mathcal{U}_\alpha \cup \mathcal{D}$. Then \vec{X}_α is no longer a sequence of positive sets and therefore all the hypothesis are fulfilled. So assume instead that $\mathcal{C}(X_n) \subseteq \mathcal{U}_\alpha$ for each $n \in \omega$. Pick $\kappa < \mathfrak{d}$ and a collection $\{C_\alpha : \alpha \in \kappa\}$ of compact sets such that $\mathcal{U}_\alpha = \bigcup_{\beta \in \kappa} \mathcal{C}_\beta$. Using the lemma 2.1.2, for every $\beta < \kappa$ we can define a function $f_\beta : \omega \rightarrow \omega$ such that for every $n \in \omega$ there is $S \in [X_n]^{<\omega}$ with $S \subseteq \mathcal{P}(f_\beta(n))$ such that if $A_0, \dots, A_{n+1} \in \mathcal{C}(S)$ and $F \in \mathcal{C}_\beta$ then $A_0 \cap \dots \cap A_{n+1} \cap F \neq \emptyset$. Since $\{f_\beta \mid \beta < \kappa\}$ is not a dominating family, there

is a g that is not dominated by any of the f_β . Let $P = \bigcup_{n \in \omega} \mathcal{P}(g(n)) \cap X_n$. It is clear that P is a pseudo-intersection. We will show that $\mathcal{U}_\alpha \cup \mathcal{C}(P)$ generates a filter: Let $F \in \mathcal{U}_\alpha$ and $B_0, \dots, B_n \in \mathcal{C}(P)$. Let $\beta < \kappa$ be such that $F \in \mathcal{C}_\beta$. Since $g \not\leq^* f_\beta$, there is $m > n$ such that $g(m) > f_\beta(m)$. Then there is $S \in [X_m]^{<\omega}$ with $S \subseteq \mathcal{P}(f_\beta(m)) \subseteq \mathcal{P}(g(m))$ such that if $A_0, \dots, A_{n+1} \in \mathcal{C}(S)$, then $A_0 \cap \dots \cap A_{n+1} \cap F \neq \emptyset$. We conclude recalling that $B_0, \dots, B_n \in \mathcal{C}(S)$. If $\mathcal{U}_{\alpha+1}$ is the filter generated by $\mathcal{U}_\alpha \cup \mathcal{C}(P)$, then P is a positive pseudo-intersection and therefore $\mathcal{U}_{\alpha+1}$ satisfies all the hypothesis that we require.

To finish the proof, let $\mathcal{U} = \bigcup_{\alpha < \mathfrak{c}} \mathcal{U}_\alpha$. The proposition 2.1.1 implies that \mathcal{U} is a Canjar ultrafilter. \square

On one hand we have that $\mathfrak{d} = \mathfrak{c}$ implies the existence of a Canjar ultrafilter, on the other hand, the existence of Canjar ultrafilters implies the existence of p -points. As a conclusion, the existence of Canjar ultrafilters is independent of ZFC.

2.2 Borel Canjar Filters

Canjar filters always exist: the Frechét filter is a Canjar filter. There is also a non-Canjar filter: Let $\{\mathcal{P}_n : n \in \omega\}$ be a partition of ω in infinite sets and let $\mathcal{F} = \{A \subseteq \omega : \forall n \in \omega (\mathcal{P}_n \setminus A) \text{ is finite}\}$ (this is known as the dual filter of $\emptyset \times \text{Fin}$). Using a genericity argument, it is easy to see that the generic real for $\mathbb{M}(\mathcal{F})$ is a dominant real. It follows that the filter \mathcal{F} is an $F_{\sigma\delta}$ -filter, so it is natural to ask if there is an F_σ non-Canjar filter. In [Bre98], the author showed that every F_σ ideal is a Canjar ideal. In [HH], it was asked if every Borel Canjar ideal must be F_σ . In the following section, we will answer this question positively. In order to achieve this, we need extend a characterization of Canjar ultrafilters by Blass, Hrušák and Verner in [BHV13].

In [Laf89], Laflamme introduced the following notion for ultrafilters.

Definition 2.2.1. *An ideal \mathcal{I} is a strong P^+ -ideal if for every increasing sequence $\{C_n : n \in \omega\}$ of compact sets with $C_n \subseteq \mathcal{I}^+$, there is an interval partition $\mathcal{P} = \{P_n : n \in \omega\}$ such that if $\{X_n : n \in \omega\}$ is a sequence such that $X_n \in C_n$ for all $n \in \omega$, then $\bigcup_{n \in \omega} X_n \cap P_n \in \mathcal{I}^+$.*

Laflamme noted without a proof that Canjar ultrafilters were strong P^+ -filters and asked if these two notions were equivalent. This was answered positively by Blass, Hrušák and Verner in [BHV13]. We will now extend their result to the general case.

Definition 2.2.2. *An ideal \mathcal{I} is a coherent strong P^+ -ideal if for every increasing sequence $\{C_n : n \in \omega\}$ of compact sets with $C_n \subseteq \mathcal{I}^+$, there is an interval partition $\mathcal{P} = \{P_n : n \in \omega\}$ such that if $\{X_n : n \in \omega\}$ is a sequence such that $X_n \in C_n$ for all $n \in \omega$, and has the "coherence property" for \mathcal{P} , that is if $n < m$ then $X_m \cap P_n \subseteq X_n \cap P_n$, then $\bigcup_{n \in \omega} X_n \cap P_n \in \mathcal{I}^+$.*

The difference between strong P^+ and coherent strong P^+ resides only in the requirement of the coherence property of the sequence of the X_n . The coherence property is trivially satisfied in some cases: for example, in the case where the sequence $\{X_n : n \in \omega\}$ is decreasing or if \mathcal{I} is the dual ideal of an ultrafilter. We will now prove that an ideal is Canjar if and only if it satisfies the coherent strong P^+ -ideal property.

Proposition 2.2.1 (The ultrafilter case was proved in [BHV13]). *An ideal \mathcal{I} is Canjar if and only if \mathcal{I} is a coherent strong P^+ -ideal.*

Proof. (\Rightarrow). Assume that \mathcal{I} is a Canjar ideal. Let $\{C_n : n \in \omega\}$ be an increasing sequence of compact sets such that, for each $n \in \omega$, $C_n \subseteq \mathcal{I}^+$. For every $n \in \omega$, define $A_n = \{a \in \text{Fin} : X \in C_n \Rightarrow a \cap X \neq \emptyset\}$. We will show that $A_n \subseteq (\mathcal{I}^{<\omega})^+$: Let $I \in \mathcal{I}$, we have to see that there is $a \in A_n$ such that $a \cap I = \emptyset$. Observe that $\{\{X \in C_n : y \in X\}y \notin I\}$ is an open cover for C_n . Then, it follows that there is $a \in \text{Fin}$ such that $a \cap I = \emptyset$ and $C_n = \bigcup_{y \in a} \{X \in C_n : y \in X\}$. This means that $a \in A_n$ and $a \cap I = \emptyset$. Using the fact that $\mathcal{I}^{<\omega}$ is a P^+ -ideal, then the sequence $\{A_n : n \in \omega\}$ has positive pseudo-intersection A . We will now find the required interval partition: For each $n \in \omega$, let $t_n = \max(\bigcup_{i \leq n} A \setminus A_i) + n$ and let $P_n = (t_{n-1}, t_n]$ (define $t_{-1} = -1$). We will show that $\mathcal{P} = \{P_n : n \in \omega\}$ is the partition we are looking for. In other words, we will show that, if $\{X_n : n \in \omega\}$ is a sequence satisfying the coherence property and is such that each $X_n \in C_n$, then $X = \bigcup_{n \in \omega} X_n \cap P_n$ is \mathcal{I} -positive: Suppose $X \in \mathcal{I}$, and let $a \in A$ and let $n = \max\{m \in \omega : a \cap \bigcup_{i \leq m+1} P_i \neq \emptyset\}$. Observe that $a \in A_n$ (otherwise, $a \in A \setminus A_n$ and therefore $a \subseteq [0, t_n]$) thus $a \cap X_n = \emptyset$.

Using the coherence property, we get that $\bigcup_{i \leq n} X_n \cap P_i \subseteq \bigcup_{i \leq n} X_i \cap P_i \subseteq X$ so $a \cap X \neq \emptyset$. This contradicts the fact that X is $\mathcal{I}^{<\omega}$ positive.

(\Leftarrow). Assume that \mathcal{I} is a coherent strong P^+ -ideal, we will show that $\mathcal{I}^{<\omega}$ is a P^+ -ideal: Let $\{A_n : n \in \omega\}$ be a decreasing sequence of $\mathcal{I}^{<\omega}$ positive sets, we have to find a positive pseudo-intersection. The lemma 3 implies that $\{\mathcal{C}(A_n) : n \in \omega\}$ is an increasing sequence of compact sets such that each $\mathcal{C}(A_n) \subseteq \mathcal{I}^+$, so we use that \mathcal{I} is a coherent strong P^+ -ideal to find a suitable partition $\mathcal{P} = \{P_n : n \in \omega\}$. Let $a_n = \bigcup_{i \leq n} P_i$ and let $A = \bigcup_{n \in \omega} A_n \cap \mathcal{P}(a_n)$. Clearly A is a pseudo-intersection of the sequence $\{A_n : n \in \omega\}$, so the only thing left to do is to show that A is positive: Suppose this is not the case, then there is $I \in \mathcal{I}$ such that I intersects every element of A . Let $X_n = (I \cap a_n) \cup (\omega \setminus a_n)$. Observe that $X_n \in \mathcal{C}(A_n)$ and $\{X_n : n \in \omega\}$ satisfies the coherence property, therefore $I = \bigcup_{n \in \omega} (X_n \cap P_n) \in \mathcal{I}^+$ which is a contradiction. \square

It turns out that the coherence property is not needed. In [DCZ] the authors proved that \mathcal{I} is Canjar if and only if \mathcal{I} is a strong P^+ -ideal, answering a question from [GHMC17]. As an application of the last proposition, we will show that all F_σ ideals are Canjar ideals.

Proposition 2.2.2 ([Bre98]). *Every F_σ ideal is a Canjar ideal.*

Proof. Let \mathcal{I} be an F_σ ideal. We will show that it is a coherent strong P^+ -ideal. By a theorem of Mazur (see [Maz91]) there is a lower semicontinuous submeasure $\varphi : \mathcal{P}(\omega) \rightarrow [0, \infty]$ such that $\mathcal{I} = \{A \subseteq \omega : \varphi(A) < \omega\}$.

Let $\{C_n : n \in \omega\}$ be an increasing sequence of compact \mathcal{I} positive sets. For each $n \in \omega$ it is possible to use the compactness of C_n to construct an interval partition $\{P_n : n \in \omega\}$ such that, for each $X \in C_n$, $\varphi(P_n \cap X) > n$. Then it follows easily that $\bigcup_{n \in \omega} X_n \cap P_n \in \mathcal{I}^+$ whenever $X_n \in C_n$. \square

This last proposition can be improved: In [Bre98], the author showed that if \mathcal{I} is the union of less than \mathfrak{d} compact sets, then \mathcal{I} is a Canjar ideal. We will need some notions introduced in [LL02].

Definition 2.2.3. *A tree $T \subseteq ([\omega]^{<\omega})^{<\omega}$ is an \mathcal{I}^+ -tree of finite sets if for every $t \in T$, there is $X_t \in \mathcal{I}^+$ such that $\text{suc}_T(t) = [X_t]^{<\omega}$. An ideal \mathcal{I} is a P^+ (tree)-ideal if for every \mathcal{I}^+ -tree of finite sets T , there is $b \in [T]$ such that $\bigcup_{n \in \omega} b(n) \in \mathcal{I}^+$.*

It turns out that Canjar ideals are P^+ (*tree*) ideals.

Proposition 2.2.3. *If \mathcal{I} is a Canjar ideal, then \mathcal{I} is a P^+ (*tree*) ideal.*

Proof. Let $T \subseteq ([\omega]^{<\omega})^{<\omega}$ be an \mathcal{I}^+ -tree of finite sets. We will find $b \in [T]$ such that $\bigcup_{n \in \omega} b(n) \in \mathcal{I}^+$. Denote by $\omega^{\nearrow\omega}$ the set of all increasing finite sequences of natural numbers. Recursively define a subtree $T' = \{t_s : s \in \omega^{\nearrow\omega}\} \subseteq T$ with the following properties:

1. $t_\emptyset = \emptyset$,
2. $t_{\langle n \rangle} = X_\emptyset \cap [0, n)$ for every $n \in \omega$,
3. $t_{\langle n_0, \dots, n_{m+1} \rangle} = X_{t_{\langle n_0, \dots, n_m \rangle}} \cap [n_m, n_{m+1})$.

Let $Y_\emptyset = X_\emptyset$. If $s \frown \langle n \rangle \in \omega^{\nearrow\omega}$ define $Y_{s \frown \langle n \rangle} = (Y_s \cap n) \cup (X_{s \frown \langle n \rangle} \setminus n)$ (the sequence s is defining an interval partition and the Y_s are approximating the X_s following the partition). Let $C_n = \{Y_s : s \in \omega^{\nearrow\omega} \wedge |s| \leq n\}$. By induction it can be easily shown that C_n is a compact set (the general proof is a generalization that $Y_{\langle n \rangle}$ converges to Y_\emptyset). Observe that Y_s is X_s with a finite amount of modifications, therefore $C_n \subseteq \mathcal{I}^+$. Using the fact that \mathcal{I} is a Canjar ideal, we can find an interval partition $\mathcal{P} = \{P_n \mid n \in \omega\}$ witnessing that \mathcal{I} is a coherent strong P^+ ideal. For each $n \in \omega$, let $e(n)$ be the last point of P_n and let $b = \langle t_{e|n} \rangle_{n \in \omega}$. We will show that $\bigcup_{n \in \omega} t_{e|n} \in \mathcal{I}^+$. Observe that $Y_{e|n} \in C_n$ and $\{Y_{e|n} : n \in \omega\}$ satisfies the coherence property and therefore $\bigcup_{n \in \omega} Y_{e|n} \cap P_n \in \mathcal{I}^+$. Finally note that $\bigcup_{n \in \omega} Y_{e|n} \cap P_n = \bigcup_{n \in \omega} t_{e|n}$ thus $\bigcup_{n \in \omega} t_{e|n} \in \mathcal{I}^+$. \square

It turns out that the property of being Canjar is a stronger notion than being P^+ (*tree*). However, in the Borel context, these two notions coincide (see [HMA11]). An example of a non-Canjar P^+ (*tree*) ideal will be constructed on the final section of this chapter. We are now ready to prove the main result of this chapter.

Theorem 2.2.1. *If \mathcal{I} is a Borel ideal, then the following are equivalent,*

1. \mathcal{I} is Canjar,
2. \mathcal{I} is F_σ ,
3. \mathcal{I} is P^+ (*tree*).

Proof. The equivalence between 2 and 3 was proved by Hrušák and Meza in [HMA11] and the other equivalence follows from the proposition 2.2.2 and 2.2.3. \square

As an application of the last theorem, we can prove the following result of Veličković and Louveau.

Corollary 2.2.1 (Veličković, Louveau [LV99]). *If \mathcal{I} is a Borel non F_σ -ideal then $\text{cof}(\mathcal{I}) \geq \mathfrak{d}$.*

Proof. Suppose that \mathcal{I} is an ideal such that $\text{cof}(\mathcal{I}) < \mathfrak{d}$, then it follows that $\mathbb{M}(\mathcal{I}^*)$ has a dense subset of size smaller than \mathfrak{d} . Any forcing notion with size smaller than \mathfrak{d} can not add dominating reals, and therefore \mathcal{I} is a Canjar ideal. As a Consequence, if \mathcal{I} is a Borel ideal, then \mathcal{I} is an F_σ ideal. \square

There are Borel ideals of cofinality exactly \mathfrak{d} . For example, it is easy to show that $\text{Fin} \times \text{Fin}$, which is the ideal in $\omega \times \omega$ generated by all columns $C_n = \{\langle n, m \rangle : m \in \omega\}$ and all $A \subseteq \omega \times \omega$ such that A intersects every C_n in a finite set, is a Borel ideal ($F_{\sigma\delta\sigma}$ ideal) with cofinality \mathfrak{d} . We will now focus on ideals generated by almost disjoint families.

2.3 Canjar MAD families

Given an almost disjoint family \mathcal{A} , we denote by $\mathcal{I}(\mathcal{A})$ the ideal generated by \mathcal{A} . An almost disjoint family \mathcal{A} is *Canjar* if the ideal $\mathcal{I}(\mathcal{A})$ is Canjar. In [Bre98], the author constructed a non Canjar MAD family under $\mathfrak{b} = \mathfrak{c}$ and asked if it is possible to construct one without additional axioms. We now answer his question in the affirmative.

Proposition 2.3.1. *There is a non Canjar MAD family.*

Proof. Let $\mathcal{P} = \{A_n \mid n \in \omega\}$ be a partition of ω . For every $n \in \omega$ choose \mathcal{B}_n an almost disjoint family of subsets of A_n . Construct a tree $T \subseteq ([\omega]^{<\omega})^{<\omega}$ such that for every $t \in T$ there is $n_t \in \omega$ with the property that $\text{succ}(t) = [A_{n_t}]^{<\omega}$ and make sure that if $t \neq s$ then $n_t \neq n_s$, and for every m there is a t such that $n_t = m$. For every branch $b \in [T]$ let $A_b = \bigcup_{n \in \omega} b(n)$ and note that $\mathcal{A} = \{A_b \mid b \in [T]\} \cup \bigcup \{\mathcal{B}_n \mid n \in \omega\}$ is an

almost disjoint family and $\mathcal{P} \subseteq \mathcal{I}(\mathcal{A})^{++}$. Let \mathcal{A}' be any MAD family extending \mathcal{A} . Note that $\mathcal{P} \subseteq \mathcal{I}(\mathcal{A}')^+$ so T is an $\mathcal{I}(\mathcal{A}')^+$ -tree of finite sets but it has no positive branch. \square

Interestingly, we do not know if there is a Canjar MAD family in ZFC. Obviously they exist under $\mathfrak{a} < \mathfrak{d}$. We will now give some sufficient conditions for the existence of a Canjar MAD family. Usually, we will construct a MAD family $\mathcal{A} = \{A_\alpha \mid \alpha \in \kappa\}$ recursively and in such case we will denote by $\mathcal{A}_\alpha = \{A_\xi \mid \xi < \alpha\}$. Denote by $Part$ the set of all interval partitions (partitions in finite sets) of ω . We may define an order on $Part$ as follows: given $\mathcal{P}, \mathcal{Q} \in Part$ we say that $\mathcal{P} \leq^* \mathcal{Q}$ if for almost all $Q \in \mathcal{Q}$ there is $P \in \mathcal{P}$ such that $P \subseteq Q$. In [Bla10] it is proved that the smallest size of a dominating family of interval partitions is \mathfrak{d} .

First we will give a combinatorial reformulation of $\min\{\mathfrak{d}, \mathfrak{r}\}$.

Proposition 2.3.2. *If κ is an infinite cardinal, then $\kappa < \min\{\mathfrak{d}, \mathfrak{r}\}$ if and only if for every $\langle \mathcal{P}_\alpha \mid \alpha \in \kappa \rangle$ family of interval partitions of ω , there is an interval partition $\mathcal{Q} = \{Q_n \mid n \in \omega\}$ with the property that there are disjoint $A, B \in [\omega]^\omega$ such that for all $\alpha < \kappa$, both $\bigcup_{n \in A} Q_n$ and $\bigcup_{n \in B} Q_n$ contain infinitely many intervals of \mathcal{P}_α .*

Proof. Let $\kappa < \min\{\mathfrak{d}, \mathfrak{r}\}$ and $\langle \mathcal{P}_\alpha \mid \alpha \in \kappa \rangle$ be a family of interval partitions. We may assume that for every \mathcal{P}_α and $n \in \omega$ there is a \mathcal{P}_β such that every interval of \mathcal{P}_β contains n intervals of \mathcal{P}_α . Define $f_\alpha : \omega \rightarrow \omega$ such that $f_\alpha(n)$ is the left point of the n -th interval of \mathcal{P}_α (so $f_\alpha(0) = 0$). Since $\kappa < \mathfrak{d}$, there is $g : \omega \rightarrow \omega$ such that g is not dominated by any f_α , we may as well assume that g is increasing and $g(0) = 0$. Define the interval partition $\mathcal{Q} = \{Q_n \mid n \in \omega\}$ where $Q_n = [g(n), g(n+1))$. Let M_α be the set of all $n \in \omega$ such that Q_n contains an interval of \mathcal{P}_α .

Claim 1. M_α is infinite for every $\alpha < \kappa$.

By the assumption on our family, it is enough to show that each M_α is not empty. Since $g \not\leq^* f_\alpha$, there is $n \in \omega$ such that $f_\alpha(n) < g(n)$. But then it follows that some interval of \mathcal{P}_α must be contained in one Q_m with $m < n$.

Since $\kappa < \mathfrak{r}$, we know that $\{M_\alpha \mid \alpha < \kappa\}$ is not a reaping family, so there are disjoint $A, B \in [\omega]^\omega$ such that $\omega = A \cup B$ and for every α , both

$M_\alpha \cap A$ and $M_\beta \cap B$ are infinite. It is clear that A and B are the sets we were looking for.

Now we must show that the conclusion of the proposition fails for $\kappa = \mathfrak{d}$ and $\kappa = \mathfrak{r}$. Let $\mathcal{R} = \{M_\alpha \mid \alpha \in \mathfrak{r}\}$ be a reaping family. Define \mathcal{P}_α such that every interval of \mathcal{P}_α contains one point of M_α . Assume there is an interval partition $\mathcal{Q} = \{Q_n \mid n \in \omega\}$ and $A, B \in [\omega]^\omega$ as in the proposition. Let $X = \bigcup_{n \in A} Q_n$. Then no M_α reaps X , which is a contradiction since \mathcal{R} was a reaping family.

Finally, let $\langle \mathcal{P}_\alpha \mid \alpha \in \mathfrak{d} \rangle$ be a dominating family of partitions and let \mathcal{Q} be any other partition. Then there is a P_α such that every interval of P_α contains two intervals of \mathcal{Q} , so obviously there can not be any A and B as required. \square

Using the proposition, we may prove the following result.

Proposition 2.3.3. *If $\mathfrak{d} = \mathfrak{r} = \mathfrak{c}$ then there is a Canjar MAD family of size continuum (In particular, there is one if $\mathfrak{b} = \mathfrak{c}$ or $\text{cov}(\mathcal{M}) = \mathfrak{c}$).*

Proof. Let \mathcal{B} be a MAD family of size \mathfrak{c} . Enumerate $\langle \bar{X}_\alpha \mid \omega \leq \alpha < \mathfrak{c} \rangle$ the set of decreasing sequences of chains of finite subsets of ω and let $[\omega]^\omega = \{Y_\alpha \mid \omega \leq \alpha < \mathfrak{c}\}$. We will recursively construct a MAD family $\mathcal{A} = \{A_\alpha \mid \alpha \in \mathfrak{c}\}$ and $\mathcal{P} = \{P_\alpha \mid \alpha \in \mathfrak{c}\}$ such that,

1. for every $A_\xi \in \mathcal{A}_\alpha$ there is $B_\xi \in \mathcal{B}$ such that $A_\xi \subseteq B_\xi$. In this way, \mathcal{A}_α is almost disjoint but it is not MAD,
2. if \bar{X}_α is a decreasing sequence of positive sets of $(\mathcal{I}(\mathcal{A}_\alpha)^{<\omega})^+$ then P_α is a pseudointersection,
3. if $\beta \leq \alpha$ then $P_\alpha \in (\mathcal{I}(\mathcal{A}_\alpha)^{<\omega})^+$,
4. if Y_α is almost disjoint with \mathcal{A}_α then $A_\alpha \subseteq Y_\alpha$.

It should be obvious that if we manage to do the construction, then we would have built a Canjar MAD family. We start by taking any partition $\{A_n \mid n \in \omega\}$ of ω in infinite sets. Assume that we have already defined \mathcal{A}_α , we will see how to find A_α . If \bar{X}_α is not a sequence of elements in $(\mathcal{I}(\mathcal{A}_\alpha)^{<\omega})^+$ then we define $P_\alpha = \text{fin}$. Otherwise, (since $\mathfrak{d} = \mathfrak{c}$) we may find P_α a positive pseudo-intersection.

Now assume that Y_α is almost disjoint with \mathcal{A}_α (if not, take as Y_α any other set almost disjoint from \mathcal{A}_α , note there is always one since \mathcal{A}_α is not MAD). Call \mathcal{D} the set of all finite unions of elements of \mathcal{A}_α and for every $\xi \leq \alpha$ and $B \in \mathcal{D}$ define an interval partition $\mathcal{P}_{\xi B} = \{P_{\xi B}(n) \mid n \in \omega\}$ with the following properties:

1. for every $n \in \omega$ there is $s \subseteq P_{\xi B}(n)$ such that $s \in P_\xi$ and $s \cap B = \emptyset$,
2. every $P_{\xi B}(n)$ contains an element of Y_α .

Since $\langle \mathcal{P}_{\xi B} \mid \xi \leq \alpha \wedge B \in \mathcal{B} \rangle$ has size less than $\max\{\mathfrak{d}, \mathfrak{r}\}$, by the previous result, there is an interval partition $\mathcal{Q} = \{Q_n \mid n \in \omega\}$ and C, D disjoint such that both $\bigcup_{n \in C} Q_n$ and $\bigcup_{n \in D} Q_n$ contains infinitely many intervals of each $\mathcal{P}_{\xi B}$. Define $A'_\alpha = \bigcup_{n \in C} (Q_n \cap Y_\alpha)$, then A'_α satisfies all the requirements except that it may not be contained in some element of \mathcal{B} . However, since \mathcal{B} is MAD we may find $B_\alpha \in \mathcal{B}$ such that $A'_\alpha \cap B_\alpha$ is infinite and then we just define $A_\alpha = A'_\alpha \cap B_\alpha$. \square

Given an almost disjoint family \mathcal{A} , we will denote by $(\mathcal{I}(\mathcal{A})^{<\omega})^{++}$ the set of all $X \in (\mathcal{I}(\mathcal{A})^{<\omega})^+$ such that there is $\{A_n \mid n \in \omega\} \subseteq \mathcal{A}$ with the property that each A_n contains infinitely many elements of X . Note that if \mathcal{A}' is an almost disjoint family with $\mathcal{A} \subseteq \mathcal{A}'$ and $X \in (\mathcal{I}(\mathcal{A})^{<\omega})^{++}$ then $X \in (\mathcal{I}(\mathcal{A}')^{<\omega})^+$. The purpose of this definition is the following: assume that we want to construct (recursively) $\mathcal{A} = \{A_\alpha \mid \alpha \in \kappa\}$ a Canjar MAD family, at some stage α of the construction, we may look at some decreasing sequence $\langle X_n \mid n \in \omega \rangle \subseteq (\mathcal{I}(\mathcal{A}_\alpha)^{<\omega})^+$ and somehow we manage to find a pseudointersection P_α with $P_\alpha \in (\mathcal{I}(\mathcal{A}_\alpha)^{<\omega})^+$, we must make sure that P remains positive in the future extensions of \mathcal{A}_α . In the previous proof, we made sure that at each step of the construction, we preserved the positiveness of all the P_α . Another approach would be to make sure that $P_\alpha \in (\mathcal{I}(\mathcal{A}_\alpha)^{<\omega})^{++}$.

Lemma 2.3.1. *If \mathcal{A} is an almost disjoint family such that for every decreasing sequence $\langle X_n \mid n \in \omega \rangle$ of $(\mathcal{I}(\mathcal{A})^{<\omega})^+$ there is a pseudointersection $P \in (\mathcal{I}(\mathcal{A})^{<\omega})^{++}$, then \mathcal{A} is a Canjar MAD family.*

Proof. The proof follows easily from the proposition 2.1.1. \square

Lemma 2.3.2. *Let $\mathcal{A} = \{A_n \mid n \in \omega\}$ be an almost disjoint family and let $\langle X_n \mid n \in \omega \rangle$ in $(\mathcal{I}(\mathcal{A})^{<\omega})^+$ be a decreasing sequence. Then there is an increasing $f : \omega \rightarrow \omega$ such that for every $n \in \omega$ there is $s_n \in \mathcal{P}(f(n) - f(n-1)) \cap X_n$ and $s_n \cap (A_0 \cup \dots \cup A_n) = \emptyset$ (for ease of writing, assume that $f(-1) = 0$).*

Proof. It follows easily from the definitions. \square

Moreover, note that f can be obtained in a completely definable way. We must also remark that if we define $P = \bigcup_{n \in \omega} X_n \cap \mathcal{P}(f(n))$ and $B = \bigcup_{n \in \omega} (f(n) - A_0 \cup \dots \cup A_n)$ then P will be a positive pseudointersection of $\{X_n : n \in \omega\}$, B will contain infinitely many elements of P and $\mathcal{A} \cup \{B\}$ will be an AD family.

The following guessing principle was defined in [MHD04],

$\diamond(\mathfrak{b})$ For every Borel coloring $C : 2^{<\omega_1} \rightarrow \omega^\omega$ there is a $G : \omega_1 \rightarrow \omega^\omega$ such that for every $R \in 2^{\omega_1}$ the set $\{\alpha \mid C(R \upharpoonright \alpha) \neq G(\alpha)\}$ is stationary (such G is called a *guessing sequence for C*).

Recall that a coloring $C : 2^{<\omega_1} \rightarrow \omega^\omega$ is *Borel* if for every α , the function $C \upharpoonright 2^\alpha$ is Borel. It is easy to see that $\diamond(\mathfrak{b})$ implies that $\mathfrak{b} = \omega_1$ and in [MHD04] it is proved that it also implies $\mathfrak{a} = \omega_1$.

Proposition 2.3.4. *Assuming $\diamond(\mathfrak{b})$, there is a Canjar MAD family.*

Proof. For every $\alpha < \omega_1$ fix an enumeration $\alpha = \{\alpha_n \mid n \in \omega\}$. With a suitable coding, the coloring C will be defined on pairs $t = (\mathcal{A}_t, X_t)$ where $\mathcal{A}_t = \langle A_\xi \mid \xi < \alpha \rangle$ and $X_t = \langle X_n \mid n \in \omega \rangle$. We define $C(t)$ to be the constant 0 function in case \mathcal{A}_t is not an almost disjoint family or if X_t is not a decreasing sequence of $(\mathcal{I}(\mathcal{A}_t)^{<\omega})^+$. In the other case, let $C(t)$ be the function obtained by the previous lemma with $\mathcal{A} = \{A_{\alpha_n} \mid n \in \omega\}$ and X_t . Using $\diamond(\mathfrak{b})$, let $G : \omega_1 \rightarrow \omega^\omega$ be a guessing sequence for C . By changing G if necessary, we may assume that all the $G(\alpha)$ are increasing and if $\alpha < \beta$ then $G(\alpha) <^* G(\beta)$.

We will now define our MAD family: start by taking $\{A_n \mid n \in \omega\}$ a partition of ω . Having defined A_ξ for all $\xi < \alpha$, we proceed to define

$$A_\alpha = \bigcup_{n \in \omega} (G(\alpha)(n) - A_{\alpha_0} \cup \dots \cup A_{\alpha_n})$$

in case this is an infinite set, otherwise take any A_α that is almost disjoint from \mathcal{A}_α . We will see that \mathcal{A} is a Canjar MAD family. Let $X = \langle X_n \mid n \in \omega \rangle$ be a decreasing sequence in $(\mathcal{I}(\mathcal{A})^{<\omega})^+$. Consider the branch $R = (\langle A_\xi \mid \xi < \omega_1 \rangle, X)$ and pick $\beta^0, \beta^1, \beta^2, \dots$ such that $C(R \upharpoonright \beta^n) * \not\leq G(\beta^n)$. Choose α bigger than all the β^n and define $h = G(\alpha)$ and $P = \bigcup_{n \in \omega} \mathcal{P}(h(n)) \cap X_n$. It is clear that P is a pseudointersection of X . We will now just show that $P \in (\mathcal{I}(\mathcal{A}_\alpha)^{<\omega})^{++}$ and we will do this by proving that each A_{β^n} contains infinitely many elements of P .

Fix $n \in \omega$ and let $t = R \upharpoonright \beta^n$. Since $C(t) * \not\leq G(\beta^n)$ we may find m such that $C(t)(m) < G(\beta^n)(m) < h(m)$. In such case (by the property of $C(t)$) there is $s \in \mathcal{P}(C(t)(m)) \cap X_m$ disjoint from $A_{\beta_0^n}, \dots, A_{\beta_m^n}$ and then $s \subseteq A_{\beta^n}$ and $s \in P$. \square

We quote an instance of a very general theorem from [MHD04].

Proposition 2.3.5 ([MHD04]). *Let $\langle \mathbb{Q}_\alpha \mid \alpha \in \omega_2 \rangle$ be a sequence of Borel proper partial orders where each \mathbb{Q}_α is forcing equivalent to $\mathcal{P}(2)^+ \times \mathbb{Q}_\alpha$ and let \mathbb{P}_{ω_2} be the countable support iteration of this sequence. If $\mathbb{P}_{\omega_2} \Vdash \text{“}\mathfrak{b} = \omega_1\text{”}$ then $\mathbb{P}_{\omega_2} \Vdash \text{“}\diamond(\mathfrak{b})\text{”}$.*

With the aid of the previous result, we can prove that there are Canjar MAD families in many of the models obtained by countable support iteration.

Corollary 2.3.1. *Let $\langle \mathbb{Q}_\alpha \mid \alpha \in \omega_2 \rangle$ be a sequence of Borel proper partial orders where each \mathbb{Q}_α is forcing equivalent to $\mathcal{P}(2)^+ \times \mathbb{Q}_\alpha$ and let \mathbb{P}_{ω_2} be the countable support iteration of this sequence. Let $G \subseteq \mathbb{P}_{\omega_2}$ be generic, then there is a Canjar MAD family in $V[G]$.*

Proof. If in $V[G]$ happens that \mathfrak{b} is ω_2 then we already know there is a Canjar MAD family. Otherwise $\mathfrak{b} = \omega_1$ and then $\diamond(\mathfrak{b})$ holds in $V[G]$ so there is a Canjar MAD family. \square

Recall that a forcing is ω^ω -bounding if it does not add unbounded reals (or, equivalently, the ground model reals still form a dominating family). Given a forcing \mathbb{P} and a Canjar MAD family \mathcal{A} , we say that \mathcal{A} is \mathbb{P} MAD-Canjar indestructible if it remains Canjar MAD after forcing with \mathbb{P} . We will see that under CH, no proper ω^ω -bounding forcing of size ω_1

can destroy all Canjar MAD families. If \mathbb{P} is a partial order, \dot{a} is a \mathbb{P} name and $G \subseteq \mathbb{P}$ is a generic filter, we will denote by $\dot{a}[G]$ the evaluation of \dot{a} according to the generic filter G .

Proposition 2.3.6. *Assume CH and let \mathbb{P} be a proper ω^ω -bounding forcing of size ω_1 . Then there is a \mathbb{P} MAD-Canjar indestructible family.*

Proof. Using the Continuum Hypothesis and the properness of \mathbb{P} , we may find a set $H = \{(p_\alpha, \dot{W}_\alpha) \mid \alpha \in \omega_1\}$ such that for all p and \dot{X} , if p forces that \dot{X} is a decreasing sequence of positive sets, then there is α such that $p \geq p_\alpha$ and $p_\alpha \Vdash \dot{W}_\alpha = \dot{X}$.

We will construct a MAD family $\mathcal{A} = \{A_\alpha \mid \alpha \in \omega_1\}$ such that if p_α forces that \dot{W}_α is a decreasing sequence of positive sets in $(\mathcal{I}(\mathcal{A}_\alpha)^{<\omega})^+$, then there is $q \leq p_\alpha$ with the property that there is \dot{P}_α such that q forces that \dot{P}_α is a pseudointersection of \dot{W}_α and that \dot{P}_α is in $(\mathcal{I}(\mathcal{A}_\alpha)^{<\omega})^{++}$ (hence q will force that \dot{P}_α is in $(\mathcal{I}(\mathcal{A})^{<\omega})^+$).

First take $\{A_n \mid n \in \omega\}$ a partition of ω . Assume that we have defined \mathcal{A}_α . We will see how to define $\mathcal{A}_{\alpha+\omega}$. In case p_α does not force that \dot{W}_α is a decreasing sequence of positive sets in $(\mathcal{I}(\mathcal{A}_\alpha)^{<\omega})^+$ then take $\mathcal{A}_{\alpha+\omega}$ be any almost disjoint family extending \mathcal{A}_α . Now assume otherwise, write $\alpha = \{\alpha_n \mid n \in \omega\}$ and let $G \subseteq \mathbb{P}$ be a generic filter with $p_\alpha \in G$. Since \mathcal{A}_α is countable and $\dot{W}_\alpha[G] = \langle \dot{W}_\alpha(n)[G] \mid n \in \omega \rangle \in V[G]$ is a sequence of positive sets in $V[G]$, there is an interval partition $\mathcal{P} = \{P_n \mid n \in \omega\} \in V[G]$ such that for all $n \in \omega$, there is $s_n \subseteq P_n$ such that $s_n \in \dot{W}_\alpha(n)[G]$ and s_n is disjoint from $A_{\alpha_0} \cup \dots \cup A_{\alpha_n}$. Define $P_\alpha = \bigcup (P_n \cap \dot{W}_\alpha(n)[G])$. Let $q' \leq p_\alpha$ force that $\dot{\mathcal{P}}$ is an interval partition and every \dot{P}_n contains an element in $\dot{W}_\alpha(n)$ disjoint from $A_{\alpha_0} \cup \dots \cup A_{\alpha_n}$. Since \mathbb{P} is ω^ω -bounding, there is $q \leq q'$ and $\mathcal{Q} = \{Q_n \mid n \in \omega\}$ a ground model partition such that $q \Vdash \dot{\mathcal{P}} \leq \mathcal{Q}$. Let $\{D_n \mid n \in \omega\}$ be a partition of ω with $D_n = \{d_n^i \mid i \in \omega\}$. Define $A_{\alpha+n} = \bigcup_{n \in \omega} (P_{d_n^i} - A_{\alpha_0} \cup \dots \cup A_{\alpha_n})$, then $\mathcal{A}_{\alpha+\omega}$ is an AD family and q forces that each $A_{\alpha+n}$ contains infinitely many elements of \dot{P}_α . \square

Corollary 2.3.2. *There are Canjar MAD families in the Cohen, Random, Hechler, Sacks, Laver, Miller and Mathias model.*

Proof. We have already proved it for the models obtained by countable support iteration and in the Cohen and Hechler models since $\text{cov}(\mathcal{M})$ is

equal to \mathfrak{c} . It only remains to check it for the Random real model. Assume CH and denote by $\mathbb{B}(\kappa)$ the forcing notion for adding κ random reals. Let $G \subseteq \mathbb{B}(\omega_2)$ be a generic filter, we want to see that there is a Canjar MAD family in $V[G]$. By the previous proposition, we know there is \mathcal{A} a $\mathbb{B}(\omega_1)$ MAD-Canjar indestructible family. It is easy to see that \mathcal{A} is $\mathbb{B}(\omega_2)$ MAD-Canjar indestructible (since every new real in $V[G]$ appears in an intermediate extension after adding only ω_1 random reals). \square

Although there still may be models without Canjar MAD families, it is easy to show that there are always uncountable Canjar almost disjoint families. Let $C_n = \{n\} \times \omega$ and given a family of increasing functions $\mathcal{B} = \{f_\alpha \mid \alpha \in \omega_1\} \subseteq \omega^\omega$ such that if $\alpha < \beta$ then $f_\alpha <^* f_\beta$ define $\mathcal{A}_\mathcal{B} = \mathcal{B} \cup \{C_n \mid n \in \omega\}$ and note that it is an almost disjoint family.

Proposition 2.3.7. *There is a family $\mathcal{B} = \{f_\alpha \mid \alpha \in \omega_1\}$ such that $\mathcal{A}_\mathcal{B}$ is Canjar, so there is an uncountable Canjar almost disjoint family.*

Proof. If $\omega_1 < \mathfrak{d}$ then any well ordered dominating family will work. Assume that $\mathfrak{d} = \omega_1$. Let $\mathcal{B} = \{f_\alpha \mid \alpha \in \omega_1\}$ be a well-ordered dominating family. For every $\alpha < \omega_1$ define $L_\alpha = \{(n, m) \mid m < f_\alpha(n)\}$ and for a given X define $X(\alpha) = X \cap [L_\alpha]^{<\omega}$. We will show that $\mathcal{I}(\mathcal{A}_\mathcal{B})^{<\omega}$ is a P^+ -ideal and to show that, we will need the following “reflection property” due to Nyikos (see [Nyi92]),

Claim 2. *If $X \in (\mathcal{I}(\mathcal{A})^{<\omega})^+$ then $X(\alpha) \in (\mathcal{I}(\mathcal{A})^{<\omega})^+$ for some $\alpha < \omega_1$.*

Assume this is not the case, so for every $\alpha < \omega_1$ the set $X(\alpha) \in \mathcal{I}(\mathcal{A}_\mathcal{B})^{<\omega}$, which means there is $F_\alpha \in [\alpha]^{<\omega}$ and $n_\alpha \in \omega$ such that $Z_\alpha = \bigcup_{\xi \in F_\alpha} f_\xi \cup \bigcup_{i \leq n_\alpha} C_i$ intersects every element of $X(\alpha)$. By a trivial application of elementary submodels, there are $S \subseteq \omega_1$ a stationary set, F a finite subset of ω_1 and $n \in \omega$ such that $F = F_\alpha$ and $n_\alpha = n$ for every $\alpha \in S$, call $Z = \bigcup_{\xi \in F} f_\xi \cup \bigcup_{i \leq n} C_i \in \mathcal{I}(\mathcal{A}_\mathcal{B})$.

Given $s \subseteq \omega \times \omega$, define $\pi(s) = \{n \mid \exists m ((n, m) \in s)\}$. As $X \in (\mathcal{I}(\mathcal{A}_\mathcal{B})^{<\omega})^+$ we may find a sequence $Y = \{x_n \mid n \in \omega\} \subseteq X$ such that $x_n \cap Z = \emptyset$ and $\max(\pi(x_n)) < \min(\pi(x_{n+1}))$ for all $n \in \omega$. Since \mathcal{B} is a well-ordered dominating family of increasing functions, there is $\alpha \in S$ such that the set $Y \cap L_\alpha$ is infinite. Note that $Z_\alpha = Z$ so $x_n \cap Z_\alpha = \emptyset$ for all $x_n \in Y \cap L_\alpha$ which contradicts the choice of F_α and n_α .

We are ready to show that $\mathcal{I}(\mathcal{A}_{\mathcal{B}})^{<\omega}$ is a P^+ -ideal. Let $\langle X_n \mid n \in \omega \rangle$ be a decreasing sequence of positive sets. Find α such that $X_n(\alpha) \in (\mathcal{I}(\mathcal{A})^{<\omega})^+$ for all $n \in \omega$ (this is possible because if $\beta < \gamma$ and $X_n(\beta)$ is positive $X_n(\gamma)$ is positive). Let $\alpha = \{\alpha_n \mid n \in \omega\}$. For every $n \in \omega$ choose $x_n \in X_n$ such that x_n is disjoint from $\bigcup_{i \leq n} f_{\alpha_i} \cup \bigcup_{i \leq n} C_i$ then it is easy to see that $X = \{x_n \mid n \in \omega\}$ is a positive pseudointersection. \square

In particular,

Corollary 2.3.3. *There is a non Borel Canjar ideal generated by ω_1 sets.*

Proof. By the previous result, we know there is $\mathcal{B} = \{f_\alpha \mid \alpha \in \omega_1\}$ such that $\mathcal{I}(\mathcal{A}_{\mathcal{B}})$ is Canjar, it is enough to show it is not F_σ . Assume otherwise, so it must be F_σ . Let $\mathcal{I}(\mathcal{A}_{\mathcal{B}}) = \bigcup_{n \in \omega} C_n$ where each C_n is a compact set. Clearly, there is $n \in \omega$ such that C_n contains uncountably many elements of \mathcal{B} . Note that $C_n \cap \mathcal{B} = C_n \cap \omega^\omega$ so $A = C_n \cap \mathcal{B}$ is a Borel set. For a given Z subset of a Polish space, recall the following definition (see [TF95])

OCA(Z) If $c : Z^2 \rightarrow 2$ is a coloring such that $c^{-1}(0)$ is open, then either Z has an uncountable 0-monochromatic set, or Z is the union of countable many 1-monochromatic sets.

In [TF95] it is proved that OCA(Z) is true for every analytic set, so in particular OCA(A) is true. However, we will arrive to a contradiction using the same argument that OCA implies that $\mathfrak{b} = \omega_2$ (see [TF95]). \square

2.4 The consistency of $\mathfrak{b} < \mathfrak{s}$ and $\mathfrak{b} < \mathfrak{a}$

It is a well-known result of Shelah that the unboundedness number can be smaller than the splitting number. He achieved this result by using a countable support iteration of a creature forcing (see [AM10], [BR] or [She98]). Using a modification of the previous forcing, he also constructed a model where the unboundedness number is smaller than the almost disjointness number. Brendle and Raghavan in [BR] showed that the partial orders of Shelah can be decomposed as an iteration of two

simpler forcings. In this section we will show how to use this decomposition to give alternative proofs of Shelah's results. The consistency of $\mathfrak{b} < \mathfrak{s}$ and $\mathfrak{b} < \mathfrak{a}$ may also be achieved using finite support iteration, as was proved by Brendle [Bre98], and Brendle and Fischer [BF11]. We will need the following notion.

Definition 2.4.1. *Let \mathcal{B} be an unbounded \leq^* well ordered family of increasing functions. A filter \mathcal{F} a \mathcal{B} -Canjar filter if $\mathbb{M}(\mathcal{F})$ preserves the unboundedness of \mathcal{B} .*

We will give a combinatorial equivalence of this definition, similar to 2.1.1. Let $\vec{X} = \{X_n : n \in \omega\}$ be a decreasing sequence of sets such that $X_n \subseteq \text{Fin}$. For every $f \in \mathcal{B}$, we define the set $\vec{X}_f = \bigcup_{n \in \omega} (X_n \cap \mathcal{P}(f(n)))$. It is easy to see that \vec{X}_f is a pseudo-intersection of \vec{X} . Observe that if $f \leq^* g$, then $\vec{X}_f \subseteq^* \vec{X}_g$. We will say that \vec{X} has a *pseudo-intersection according to \mathcal{B}* if there is $f \in \mathcal{B}$ such that \vec{X}_f is positive. We will say that the filter $\mathcal{F}^{<\omega}$ is a P^+ -filter according to \mathcal{B} if every decreasing sequence \vec{X} of positive sets has a pseudo-intersection according to \mathcal{B} . The following proposition is the analogous of 2.1.1.

Proposition 2.4.1. *\mathcal{F} is a \mathcal{B} -Canjar filter if and only if $\mathcal{F}^{<\omega}$ is a P^+ -filter according to \mathcal{B} .*

Proof. The proof is similar to 2.1.1, we will repeat the proof for the convenience of the reader.

(\Rightarrow). Suppose that \mathcal{F} is a \mathcal{B} -Canjar filter, we will see that $\mathcal{F}^{<\omega}$ is a P^+ -filter according to \mathcal{B} . Let $\{X_n : n \in \omega\}$ be a decreasing sequence of $\mathcal{F}^{<\omega}$ positive sets and let $G \subseteq \mathbb{M}(\mathcal{F})$ be a generic filter. Working in $V[G]$ let $m_{gen} = \bigcup \{s \in [\omega]^{<\omega} : \exists F \in \mathcal{F} (\langle s, F \rangle \in G)\}$. By genericity $\text{Fin}(m_{gen})$ intersects every X_m infinitely, therefore, in $V[G]$, it is possible to define $g : \omega \rightarrow \omega$ with the property that $(m_{gen} \setminus n) \cap g(n)$ contains a member of X_n . Now, using that \mathcal{F} is \mathcal{B} -Canjar, we can find an $f \in \mathcal{B}$ such that $\mathbb{M}(\mathcal{F}) \Vdash "f \not\leq g"$. We will show that \vec{X}_f is $\mathcal{F}^{<\omega}$ positive: Let $F \in \mathcal{F}$, we will find $s \subseteq F$ such that $s \in \vec{X}_f$. Pick a condition $\langle t, G \cap F \rangle$ and $n \in \omega$ such that $\langle t, G \cap F \rangle \Vdash "m_{gen} \setminus n \subseteq F"$. Finally, pick a stronger condition $\langle t \cup s, G' \rangle \leq \langle t, G \rangle$ and $k > n$ such that $\langle t \cup s, G' \rangle \Vdash "f(k) \geq g(k)"$. This implies that, in the extension of a generic filter containing $\langle t \cup s, G' \rangle$, $s \subseteq g(k)$ and $s \in X_k$. It follows that $s \in \vec{X}_f$.

(\Leftarrow). Suppose that \mathcal{F} is not \mathcal{B} -Canjar, we will see that $\mathcal{F}^{<\omega}$ is not a P^+ -filter according to \mathcal{B} . Let \dot{g} be an $\mathbb{M}(\mathcal{F})$ -name of a function dominating \mathcal{B} . For each $f \in \mathcal{B}$ pick $\langle s_f, F_f \rangle \in \mathbb{M}(\mathcal{F})$ and $n_f \in \omega$ such that

$$\langle s_f, F_f \rangle \Vdash \text{“}\forall n \geq n_f (f(n) \leq \dot{g}(n))\text{”}.$$

Choose $s \in \omega^{<\omega}$, $n \in \omega$ and $\mathcal{B}' \subseteq \mathcal{B}$ such that \mathcal{B}' is cofinal in \mathcal{B} and for every $f \in \mathcal{B}'$, $s_f = s$ and $n_f = n$. For each $m \in \omega$, let

$$X_m = \{t \in [\omega \setminus s]^\omega : \exists F \in \mathcal{F} (\langle t, F \rangle \text{ knows the value of } \dot{g}(0), \dots, \dot{g}(m))$$

$$\text{and } \langle s \cup t, F \rangle \Vdash \text{“}\dot{g}(m) < \max(t)\text{”}\}.$$

It is easy to see that $\{X_m : m \in \omega\}$ is a decreasing sequence of sets. If $F \in \mathcal{F}$, then it is possible to find a $t \in [\omega \setminus s]^\omega$ and $F' \in \mathcal{F}$ such that $F' \subseteq F$ and $\langle s \cup t, F' \rangle \Vdash \text{“}\dot{g}(m) < \max(t)\text{”}$, so therefore each X_m is an $F^{<\omega}$ positive set. We will show that no pseudo-intersection according to \mathcal{B}' (and therefore according to \mathcal{B}) can be positive: Suppose this is not the case and let $f \in \mathcal{B}'$ be such that \vec{X}_f is a positive pseudo-intersection of $\{X_n : n \in \omega\}$. Note that, for each $k \in \omega$, $\vec{X}_f \cap (X_k \setminus X_{k+1})$ is finite, so let $f(k) = (\max(\bigcup \vec{X}_f \cap (X_k \setminus X_{k+1}))) + 1$ and let $h \in \mathcal{B}'$ and $m > n_h$ be such that $h(i) \geq f(i)$ for every $i > m$. Choose $k > m$ such that $X_k \setminus X_{k+1} \neq \emptyset$. It follows that

$$\langle s, F_h \rangle \Vdash \text{“}h(k) \leq \dot{g}(k)\text{”}.$$

Observe that $\vec{X}_f \cap X_k$ is positive, therefore there exist $t \in \vec{X}_f \cap X_k$ such that $t \subseteq F_h$, and therefore

$$\langle s \cup t, F_h \setminus t \rangle \Vdash \text{“}h(k) \leq \dot{g}(k)\text{”}$$

However this contradicts the fact that $f(k) \geq h(k) > \max(t)$ and $t \in X_k$. \square

Definition 2.4.2. We say \mathcal{F} is strongly Canjar if \mathcal{F} is \mathcal{B} -Canjar for every well ordered and unbounded \mathcal{B} .

Note that the proof that every F_σ filter is Canjar, actually shows that every F_σ filter is strongly Canjar.

Definition 2.4.3. Define \mathbb{F}_σ as the set of all F_σ filters and we consider it as a forcing notion by ordering it by inclusion.

It is easy to see that \mathbb{F}_σ is σ -closed and if $G \subseteq \mathbb{F}_\sigma$ is a generic filter, then $\bigcup G$ is an ultrafilter. We denote the name of this ultrafilter by \dot{U}_{gen} . Laflamme showed that this is a strong P -point, we will reprove this below.

Note that if \mathcal{U} is an ultrafilter and $X \subseteq fin$, then $X \in (\mathcal{U}^{<\omega})^+$ if and only if $\mathcal{C}(X) \in \mathcal{U}$. It follows that if \mathcal{F} is an F_σ filter then $\mathcal{F} \Vdash "X \in (\mathcal{U}^{<\omega})^+ "$ if and only if $\mathcal{C}(X) \subseteq \mathcal{F}$.

Proposition 2.4.2. Let \mathcal{B} be an unbounded well order family. Then \mathbb{F}_σ forces that \dot{U}_{gen} is \mathcal{B} -Canjar.

Proof. By the previous observation and since \mathbb{F}_σ is σ -closed, it is enough to show that if $\mathcal{F} \Vdash "\bar{X} = \langle X_n \rangle_{n \in \omega} \subseteq (\dot{U}_{gen}^{<\omega})^+ "$ then there is $\mathcal{G} \leq \mathcal{F}$ and $f \in \mathcal{B}$ such that $\mathcal{C}(\bar{X}_f) \subseteq \mathcal{G}$.

Let $\mathcal{F} = \bigcup \mathcal{C}_n$ where each \mathcal{C}_n is compact and they form an increasing chain. By lemma 2.1.2 there is $g : \omega \rightarrow \omega$ such that if $n \in \omega$, $F \in \mathcal{C}_n$ and $A_0, \dots, A_n \in \mathcal{C}(X_n \cap \mathcal{P}(g(n)))$ then $A_0 \cap \dots \cap A_n \cap F \neq \emptyset$. Since \mathcal{B} is unbounded, then there is $f \in \mathcal{B}$ such that $f \not\leq^* g$. We claim that $\mathcal{F} \cup \mathcal{C}(\bar{X}_f)$ generates a filter. Let $F \in \mathcal{C}_n$ and $A_0, \dots, A_m \in \mathcal{C}(\bar{X}_f)$ we must show that $A_0 \cap \dots \cap A_m \cap F \neq \emptyset$. Since f is not bounded by g , we may find $r > n, m$ such that $f(r) > g(r)$. In this way, $A_0, \dots, A_n \in \mathcal{C}(X_n \cap \mathcal{P}(g(n)))$ and then $A_0 \cap \dots \cap A_m \cap F \neq \emptyset$. Finally, we can define \mathcal{G} as the generated filter by $\mathcal{F} \cup \mathcal{C}(\bar{X}_f)$. \square

Recall that \mathbb{P} is *weakly ω^ω -bounding* if \mathbb{P} does not add dominating reals. Unlike the ω^ω -bounding property, the weakly ω^ω -bounding property is not preserved under iteration. However, Shelah proved the following preservation result,

Proposition 2.4.3 (Shelah, see [AM10]). If $\gamma \leq \omega_2$ is a limit ordinal and $\langle \mathbb{P}_\alpha, \dot{Q}_\alpha : \alpha \leq \gamma \rangle$ is a countable support iteration of proper forcings and each \mathbb{P}_α is weakly ω^ω -bounding (over V) then \mathbb{P}_γ is weakly ω^ω -bounding.

Note that \mathbb{P} is weakly ω^ω -bounding if and only if it preserves the unboundedness of every (any) dominating family. By applying the result of Shelah we can easily conclude the following result,

Corollary 2.4.1. *If V satisfies CH (it is enough to assume that V has a well ordered dominating family) and $\langle \mathbb{P}_\alpha, \dot{Q}_\alpha \mid \alpha \leq \omega_2 \rangle$ is a countable support iteration of proper forcings such that \mathbb{P}_α forces that \dot{Q}_α preserves the unboundedness of all well ordered unbounded families, then \mathbb{P}_{ω_2} is weakly ω^ω -bounding.*

We are now in position to build a model where the unboundedness number is less than the splitting number.

Theorem 2.4.1 (Shelah). *There is a model where $\mathfrak{b} < \mathfrak{s}$.*

Proof. Assume V satisfies CH and let $\langle \mathbb{P}_\alpha, \dot{Q}_\alpha \mid \alpha \leq \omega_2 \rangle$ be the countable support iteration where $\mathbb{P}_\alpha \Vdash \dot{Q}_\alpha = \mathbb{F}_\sigma * \mathbb{M}(\dot{U}_{gen})$. By the previous results, it follows that \mathbb{P}_{ω_2} is weakly ω^ω -bounding and then $\mathfrak{b} = \omega_1$ in the final model. On the other hand, since $\mathbb{F}_\sigma * \mathbb{M}(\dot{U}_{gen})$ adds an ultrafilter and then diagonalize it, it follows that it destroys all splitting families of the ground model. Therefore $\mathfrak{s} = \omega_2$ in the extension. \square

Before construction the model of $\mathfrak{b} < \mathfrak{a}$ we would like make some remarks. Recall the definition of almost ω^ω -bounding forcings,

Definition 2.4.4. *We say \mathbb{P} is almost ω^ω -bounding if for every name for a real \dot{f} and $p \in \mathbb{P}$, there is an increasing $g : \omega \rightarrow \omega$ such that for all $A \in [\omega]^\omega$ there is $p_A \leq p$ with the property that $p_A \Vdash \dot{f} \restriction A \not\leq^* g \restriction A$.*

The following is well known,

Lemma 2.4.1. *If \mathbb{P} is almost ω^ω -bounding then \mathbb{P} preserves all unbounded families of the ground model.*

Proof. Let \mathcal{B} be unbounded, \dot{f} a name for a real and $p \in \mathbb{P}$. Find $g : \omega \rightarrow \omega$ as above and since \mathcal{B} is unbounded, then there is $h \in \mathcal{B}$ and $A \in [\omega]^\omega$ such that $g \restriction A \leq h \restriction A$. It then clearly follows that p_A forces that \dot{f} does not dominate \mathcal{B} . \square

Given $A \in [\omega]^\omega$ denote by $e_A : \omega \rightarrow A$ be its enumerative function, note that if $A \subseteq^* B$ then $e_B \leq^* e_A$. It is a well known result of Talagrand (see [BJ95]) that a filter \mathcal{F} is non meager if and only if $\{e_A \mid A \in \mathcal{F}\}$ is unbounded. It follows that no almost ω^ω -bounding forcing can diagonalize a non meager filter. Since ultrafilters are non meager, we conclude the following.

Corollary 2.4.2. *If \mathcal{U} is an ultrafilter, then $\mathbb{M}(\mathcal{U})$ is not almost ω^ω -bounding.*

It follows by the works of Shelah, Brendle and Raghavan that $\mathbb{F}_\sigma * \mathbb{M}(\dot{\mathcal{U}}_{gen})$ is almost ω^ω -bounding, in spite that $\mathbb{M}(\dot{\mathcal{U}}_{gen})$ is not.

We will now build a model of $\mathfrak{b} < \mathfrak{a}$. In [Bre98] Brendle constructed a model of this result using finite support iteration. Although we will use countable support iteration, the following proof was inspired by the work of Brendle.

Given an AD family \mathcal{A} define $\mathbb{F}_\sigma(\mathcal{A}) = \{\mathcal{F} \in \mathbb{F}_\sigma \mid \mathcal{I}(\mathcal{A}) \cap \mathcal{F} = \emptyset\}$ and order it by inclusion. As before, it is easy to see that $\mathbb{F}_\sigma(\mathcal{A})$ is a σ -closed filter and it adds an ultrafilter, which we will denote by $\dot{\mathcal{U}}_{\mathcal{A}}$. The *Brendle game* $\mathcal{BR}(\mathcal{A})$ is defined as follows,

I		Y_0		Y_1		Y_2		\dots
II	\mathcal{F}, X		s_0		s_1		s_2	\dots

Where,

1. $\mathcal{F} \in \mathbb{F}_\sigma(\mathcal{A})$, $\mathcal{F} = \bigcup \mathcal{C}_n$, where the \mathcal{C}_n are compact and increasing, $X \subseteq fin$ and $\mathcal{C}(X) \subseteq \langle \mathcal{I}(\mathcal{A})^* \cup \mathcal{F} \rangle$.
2. $Y_m \in \mathcal{I}(\mathcal{A})^*$, $s_m \in [Y_m]^{<\omega}$ intersects all the elements of \mathcal{C}_m and $\max(s_m) < \min(s_{m+1})$.

Then I wins the game if $\bigcup_{n \in \omega} s_n$ contains an element of X .

Note that this is an open game for I, i.e., if she won, then she already won in a finite number of steps. In the following, $V[C_{\omega_1}]$ denotes an extension of V by adding ω_1 Cohen reals.

Lemma 2.4.2. *If \mathcal{A} is an AD family in V , then in $V[C_{\omega_1}]$ the player I has a winning strategy for $\mathcal{BR}(\mathcal{A})$.*

Proof. Assume this is not the case, since $\mathcal{BR}(\mathcal{A})$ is an open game it follows from the Gale-Steward theorem (see [Kec95]) that II has a winning strategy, call it π . Let $\mathcal{F} = \bigcup_{n \in \omega} \mathcal{C}_n \in \mathbb{F}_\sigma(\mathcal{A})$ and $X \subseteq fin$ be the first plays of II according to π (so $\mathcal{C}(X) \subseteq \langle \mathcal{I}(\mathcal{A})^* \cup \mathcal{F} \rangle$). By standard Cohen forcing arguments, we may as well assume \mathcal{F} , X and π are ground model sets. Call \mathbb{P} the set of all $p = \langle s_0, \dots, s_n \rangle$ such that there are $Y_0, \dots, Y_n \in \mathcal{I}(\mathcal{A})^*$

with the property that $(\mathcal{F}, X, Y_0, s_0, \dots, Y_n, s_n)$ is a partial play and the s_n are chosen using π . We order \mathbb{P} by extension, note that \mathbb{P} is countable, therefore is isomorphic to Cohen forcing and if $p = \langle s_0, \dots, s_n \rangle$ is a condition, then $\bigcup_{i < n} s_i$ does not contain an element of X .

Given $Y \in \mathcal{I}(\mathcal{A})^*$ and $m \in \omega$ the set $D_{Y,m}$ of all conditions p such that p contains a respond to Y and $|p| > m$ is open dense. Let $G \in V[C_{\omega_1}]$ be a (\mathbb{P}, V) generic filter. By the above observation, we conclude that $D = \bigcup G$ is a legal play on the game, and it is a winning run for II, so D does not contain any element of X . By genericity $D \in \langle \mathcal{I}(\mathcal{A})^* \cup \mathcal{F} \rangle^+$ however, $\omega - D \in \mathcal{C}(X) \subseteq \langle \mathcal{I}(\mathcal{A})^* \cup \mathcal{F} \rangle$ which is obviously a contradiction. \square

With the previous lemma we can conclude the following dichotomy,

Lemma 2.4.3. *Let $\mathcal{A} \in V$ be an AD family, then in $V[C_{\omega_1}]$ one of the following holds,*

1. \mathcal{A} can be extended to an \mathcal{F}_σ ideal or,
2. For every $\mathcal{F} \in \mathbb{F}(\mathcal{A})$ and $X_0, X_1, \dots \subseteq \text{fin}$ with the property that $\mathcal{C}(X_n) \subseteq \langle \mathcal{I}(\mathcal{A})^* \cup \mathcal{F} \rangle$ for all $n \in \omega$, there is $A \in \mathcal{A} \cap \mathcal{F}^+$ such that A contains an element of each X_n .

Proof. Assume \mathcal{A} can not be extended to an \mathcal{F}_σ ideal, let \mathcal{F} and X_n as above. By the previous lemma, let π be a winning strategy for player I. Consider the games where II began by playing \mathcal{F}, X_n and call \mathcal{W} the countable set of elements of $\mathcal{I}(\mathcal{A})^*$ that were played by I following π in any of this games. Note that if $W \in \mathcal{W}$ then W almost contains every element of \mathcal{A} except for finitely many. Let $\mathcal{A}' \subseteq \mathcal{A}$ be the countable set of all those elements of \mathcal{A} that are not almost contain in every element of \mathcal{W} . Since $\mathcal{I}(\mathcal{A})^*$ can not be extended to an \mathcal{F}_σ filter then it is not contained in $\langle \mathcal{F} \cup \{\omega - B \mid B \in \mathcal{A}'\} \rangle$ so there is $A \in \mathcal{A}$ such that $\omega - A \notin \langle \mathcal{F} \cup \{\omega - B \mid B \in \mathcal{A}'\} \rangle$, this implies that $A \in \mathcal{F}^+$ and A is almost contain in every member of \mathcal{W} . We will now show that A contains an element of each X_n . For every $n \in \omega$ consider the following play,

I		W_0		W_1		W_2		\dots
II	\mathcal{F}, X_n		s_0		s_1		s_2	\dots

Where the W_n are played by I according to π and $s_i \in [A]^{<\omega}$ and intersects every element of \mathcal{C}_i . This is possible since A is positive and is almost contained in every W_n . Since π is a winning strategy, this means that I the game, which entails that $\bigcup s_n \subseteq A$ contains an element of X_n . \square

It is easy to see that if $\mathcal{F} \in \mathbb{F}_\sigma(\mathcal{A})$ and $X \subseteq \text{fin}$, then $\mathcal{F} \Vdash "X \in \dot{\mathcal{U}}_{\mathcal{A}}^{<\omega+}"$ if and only if $\mathcal{C}(X) \subseteq \langle \mathcal{F} \cup \mathcal{I}(\mathcal{A})^* \rangle$. With this we may prove the following result.

Proposition 2.4.4. *Let \mathcal{B} be a well order unbounded family and \mathcal{A} an AD family, then in $V[C_{\omega_1}]$ either \mathcal{A} can be extended to an F_σ filter or $\mathbb{F}_\sigma(\mathcal{A}) \Vdash "M(\dot{\mathcal{U}}_{\mathcal{A}})$ is \mathcal{B} -Canjar].*

Proof. Assume \mathcal{A} can not be extended to an F_σ filter after adding ω_1 Cohen reals. In $V[C_{\omega_1}]$ let $\mathcal{F} \in \mathbb{F}_\sigma(\mathcal{A})$ and a sequence $\bar{X} = \langle X_n \mid n \in \omega \rangle$ such that \mathcal{F} forces that each X_n is in $\dot{\mathcal{U}}_{\mathcal{A}}^{<\omega+}$, so all the $\mathcal{C}(X_n)$ are contained $\langle \mathcal{F} \cup \mathcal{I}(\mathcal{A})^* \rangle$. We will find an extension of \mathcal{F} that forces that the X_n have a positive pseudointersection. Applying the previous lemma ω times, we may find distinct $A_0, A_1, A_2, \dots \in \mathcal{A}$ such that for A_n contains an element of X_m for every $n, m \in \omega$.

In this way, we may find $g : \omega \rightarrow \omega$ such that for all $n \in \omega$, there are $s_0, s_1, \dots, s_n \in X_n$ such that $s_i \subseteq A_i \cap (g(n) - n)$. By possibly enlarging g , we can assume that the pseudointersection given by g is $\mathcal{F}^{<\omega+}$. Since \mathcal{B} is unbounded, then there is $f \in \mathcal{B}$ such that $f \not\leq^* g$. It is easy to see that if we define \mathcal{G} as the filter generated by $\mathcal{F} \cup \mathcal{C}(\bar{X}_f)$ then \mathcal{G} forces that \bar{X} has a positive pseudointersection. \square

We are now in position to prove the result of Shelah.

Theorem 2.4.2 (Shelah). *There is a model where $\mathfrak{b} < \mathfrak{a}$.*

Proof. Assume V satisfies CH, define the countable support iteration $\langle \mathbb{P}_\alpha, \dot{Q}_\alpha \mid \alpha \in \omega_2 \rangle$ such that (with a suitable bookkeeping device) we destroy every MAD \mathcal{A} family either by adding Cohen reals, by forcing with an F_σ filter or with $\mathbb{F}_\sigma(\mathcal{A}) * "M(\dot{\mathcal{U}}_{\mathcal{A}})$. It is clear that this construction works. \square

2.5 Ideals generated by branches

If $b \in 2^\omega$ we denote by $\widehat{b} = \{b \upharpoonright n \mid n \in \omega\}$. Let A be a dense, co-dense subset of 2^ω . We define \mathcal{I}_A the *branching ideal* of A as the set of all $X \subseteq 2^{<\omega}$ such that there are $b_1, \dots, b_n \in A$ with the property that $X \subseteq \widehat{b}_1 \cup \dots \cup \widehat{b}_n$. Clearly, if $M \in [\widehat{b}]^\omega$ with $b \notin A$ then $M \in \mathcal{I}_A^+$, and also every infinite antichain, is positive.

Lemma 2.5.1. \mathcal{I}_A is P^+ for every $A \subseteq 2^\omega$.

Proof. This result follows since \mathcal{I}_A is the ideal generated by an infinite almost disjoint family. \square

We will now investigate when \mathcal{I}_A is P^+ (*tree*) and Canjar.

Proposition 2.5.1. *If A is the union of less than \mathfrak{d} compact sets, then \mathcal{I}_A is Canjar.*

Proof. Assume that $A = \bigcup_{\alpha < \kappa} C_\alpha$ where C_α is compact and $\kappa < \mathfrak{d}$ moreover, we may assume that for every $b_1, \dots, b_n \in A$ there is a C_α such that $b_1, \dots, b_n \in C_\alpha$. We will show that $\mathcal{I}_A^{<\omega}$ is a P^+ -ideal. Before starting the proof we must do an important observation: assume that $Y \in (\mathcal{I}_A^{<\omega})^+$ and for every $a \in Y$ define $U_a = \{b \in 2^\omega \mid a \cap \widehat{b} = \emptyset\}$ and since a is finite then U_a is open and $\langle U_a \mid a \in Y \rangle$ is an open cover of A . Therefore, every C_α is contained in only a finite number of U_a .

Let $\langle X_n \mid n \in \omega \rangle$ be a decreasing family of positive sets of $\mathcal{I}_A^{<\omega}$. For every $\alpha < \kappa$ we define $f_\alpha : \omega \rightarrow [2^{<\omega}]^{<\omega}$ such that for every if $n \in \omega$ then $f_\alpha(n) \subseteq X_n$ and $C_\alpha \subseteq \bigcup_{a \in f_\alpha(n)} U_a$. Since $\kappa < \mathfrak{d}$, there is $f : \omega \rightarrow [2^{<\omega}]^{<\omega}$ such that $f(n) \subseteq X_n$ and for all $\alpha < \kappa$ it happens that $f_\alpha(n) \subseteq f(n)$ for infinitely many $n \in \omega$. It is easy to see that $\bigcup_{n \in \omega} f(n)$ is a positive pseudointersection of $\langle X_n \mid n \in \omega \rangle$. \square

Given a topological space X , we say that an open cover \mathcal{U} is an ω -cover if for every $x_0, \dots, x_n \in X$ there is $U \in \mathcal{U}$ such that $x_0, \dots, x_n \in U$. We say that X is $S_{fin}(\Omega, \Omega)$ if for every sequence $\langle \mathcal{U}_n \mid n \in \omega \rangle$ of ω -covers, there are $F_n \in [\mathcal{U}_n]^{<\omega}$ such that $\bigcup_{n \in \omega} F_n$ is an ω -cover (see [SS] for more information concerning this type of spaces). The following was noted by Ariet Ramos.

Proposition 2.5.2. \mathcal{I}_A is Canjar if and only if A is $S_{fin}(\Omega, \Omega)$.

Proof. First assume that A is $S_{fin}(\Omega, \Omega)$ and let $\langle X_n \mid n \in \omega \rangle \subseteq (\mathcal{I}_A^{<\omega})^+$ be a decreasing sequence. Given any a we define $U_a = \{b \mid a \cap \widehat{b} = \emptyset\}$. Since each X_n is positive, $\mathcal{V}_n = \{U_a \mid a \in X_n\}$ is an ω -cover of A . In this way, $\langle \mathcal{V}_n \mid n \in \omega \rangle$ is a sequence of ω -covers, so there are $F_n \in [X_n]^{<\omega}$ such that $\{U_a \mid a \in \bigcup_{n \in \omega} F_n\}$ is an ω -cover. It is easy to see that $P = \bigcup_{n \in \omega} F_n$ is a positive pseudointersection of $\langle X_n \mid n \in \omega \rangle$.

Now, assume that \mathcal{I}_A is Canjar and let $\langle \mathcal{U}_n \mid n \in \omega \rangle$ be a sequence of ω -covers. Given an open set U , define $Y_U = \{a \mid \forall b(\widehat{b} \cap a = \emptyset \rightarrow b \in U)\}$. Define $X_n = \bigcup_{U \in \mathcal{U}_n} Y_U$. Since \mathcal{U}_n is an ω -cover, each X_n is positive. Since \mathcal{I}_A is Canjar, there are $F_n \in [X_n]^{<\omega}$ such that $P = \bigcup_{n \in \omega} F_n$ is a positive pseudointersection. For every $a \in F_n$ choose $U_a \in \mathcal{U}_n$ with the property that $a \in Y_{U_a}$. It is not difficult to check that $\{U_a \mid a \in F_n \wedge n \in \omega\}$ is an ω -cover. \square

Given an ideal \mathcal{I} we define $\mathcal{LF}(\mathcal{I})$ the *Laflamme Game on \mathcal{I}* as follows,

I	X_0		X_1		X_2		X_3	\dots
II		s_0		s_1		s_2		\dots

where each $X_n \in \mathcal{I}^+$ and s_n is a finite subset of X_n . The player *II* wins the game if $\bigcup s_n \in \mathcal{I}^+$. Laflamme proved in [LL02] that \mathcal{I} is a P^+ (tree) ideal if and only if player *I* does not have a winning strategy in $\mathcal{LF}(\mathcal{I})$. In case of branching ideals, the Laflamme game can be simplified. Given $A \subseteq 2^\omega$ define the game $\mathcal{LF}'(\mathcal{I})$ as follows,

I	b_0		b_1		b_2		b_3	\dots
II		s_0		s_1		s_2		\dots

where each $b_n \notin A$, s_n is an initial segment of b_n , $s_n \subsetneq s_{n+1}$ and $b_{n+1} \in \langle s_n \rangle$. The player *II* wins the game if $\bigcup s_n \notin A$. The analogue of the result of Laflamme is the following.

Proposition 2.5.3. \mathcal{I}_A is a P^+ (tree) ideal if and only if player *I* does not have a winning strategy in $\mathcal{LF}'(\mathcal{I})$.

Proof. It is easy to see that if I has a winning strategy in $\mathcal{LF}'(\mathcal{I})$ then she has one in $\mathcal{LF}(\mathcal{I})$ so \mathcal{I} is not P^+ (tree). For the other direction, assume that I does not have a winning strategy and let T be a \mathcal{I}_A^+ tree. We will show that there is $b \in [T]$ such that $\bigcup b \upharpoonright n \in \mathcal{I}_A^+$.

Case 1. For all $s \in T$ and $n \in \omega$ there is t an extension of s such that $\bigcup_{i < |t|} t \upharpoonright i$ can not be covered by n branches.

In this case, we simply choose s_0, s_1, \dots such that s_{n+1} extends s_n and it can not be covered by n branches. It is clear that $b = \bigcup s_n$ is as desired.

Case 2. Without loss of generality, there is $n \in \omega$ such that for every $t \in T$, the set $\bigcup_{i < |t|} t \upharpoonright i$ can be covered by n branches.

By an easy compactness argument, for every $s \in T$ there are $b_0^s, \dots, b_{n-1}^s \in 2^\omega$ such that $X_s \subseteq \widehat{b}_0^s \cup \dots \cup \widehat{b}_{n-1}^s$, $b_0^s \notin A$ and $X_s \cap \widehat{b}_0^s$ is infinite. Let $T' \subseteq T$ such that for every $t \in T'$ there is m_t with the property that $t = X_t \cap 2^{\leq m_t}$.

We say that s prefers t if s extends t , $m_s > m_t$ and $b_0^s \in \langle b_0^t \upharpoonright m_t \rangle$. We also say that t is *totally preferred* if for all $s \leq t$ there is $s' \leq s$ such that s' prefers t . We first claim that there is $t \in T$ that is totally preferred. Assume this is not the case, then we do the following:

1. Let $t_0 = \emptyset$.
2. Let $t_1 \leq t_0$ such that no extension of t_1 prefers t_0 .
3. Let $t_2 \leq t_1$ such that no extension of t_2 prefers t_1 .
4. \vdots

We keep this procedure until we find t_{n+1} , but then t_{n+1} must prefer some t_i (with $i \leq n$) which is a contradiction. Now assume t is totally preferred, we will describe π an strategy for player I .

1. First, player I plays b_0^t ,
2. if player II plays s_0 , then I finds $n_0 \geq |s_0|, \Delta(X_t)$ and let $t_0 = X_t \cap 2^{\leq n_0}$. Player I finds $t'_0 \leq t_0$ such that t'_0 prefers t and I plays $b_0^{t'_0}$.

3. if player II plays s_1 , then I finds $n_1 \geq |s_1|, \Delta(X_{t'_0})$ and let $t_1 = X_{t'_0} \cap 2^{\leq n_1}$. Player I finds $t'_1 \leq t_1$ such that t'_1 prefers t and I plays $b_0^{t'_1}$.
4. \vdots

since π is not a winning strategy, there are s_0, s_1, s_2, \dots such that if player II play s_n at round n then he will win in case I follows π . Let $d = (\pi(s_0, \dots, s_i) \upharpoonright n_i)$. Then $\bigcup d \notin A$ (since II won the game) and d is a branch through T . \square

We will now give a topological characterization of the sets such that its branching ideal is $P^+(tree)$. Recall that a topological space is a *Baire space* if no non-empty open sets are meager, and a space is called *completely Baire* if all of its closed subsets are Baire. Hurewicz proved that a space is completely Baire if and only if it does not contain a closed copy of \mathbb{Q} (see [Mil01] pages 78 and 79).

Proposition 2.5.4. \mathcal{I}_A is $P^+(tree)$ if and only if $2^\omega - A$ is completely Baire.

Proof. Assume that \mathcal{I}_A is $P^+(tree)$ and suppose that $2^\omega - A$ is not completely Baire, so there is a perfect set C such that $A \cap C = \{d_n \mid n \in \omega\}$ is countable dense in C . Consider the following strategy π for I in $\mathcal{LF}'(2^\omega - A)$.

1. I plays d_0 ,
2. if II plays s_0 , then I plays d_{n_1} where $n_1 = \min\{i > 0 \mid d_i \in \langle s_0 \rangle\}$,
3. if II plays s_1 , then I plays d_{n_2} where $n_2 = \min\{i > n_1 \mid d_i \in \langle s_1 \rangle\}$,
4. \vdots

Since this is not a winning strategy, there are s_0, s_1, s_2, \dots such that if I follows π and II plays s_i at the round i , then II will win. Let $a = \bigcup_{n \in \omega} s_n$. Then $a \in A \cap C$ since C is compact and II won the game, however, a is different than all the d_n , which is a contradiction.

Now assume that $A \cap C$ is uncountable whenever C is perfect and $A \cap C$ is dense in C . Aiming for a contradiction, assume that I has π a

winning strategy in $\mathcal{LF}'(2^\omega - A)$. Let $D \subseteq 2^\omega$ be the set of all $b \in 2^\omega$ such that there are s_0, s_1, \dots, s_n with the property that $\pi(s_0, s_1, \dots, s_n) = b$. Since π is a winning strategy, $D \subseteq A$ has no isolated points and $C = \overline{D}$ is perfect. Since D is countable, there is $b \in A \cap C - D$. Note that b corresponds to a legal play in $\mathcal{LF}'(2^\omega - A)$ in which II won (since $b \in A$) which is a contradiction. \square

For our next result, we need to recall a result from Kechris, Louveau and Woodin ([KLW87], see also [Kec95] Theorem 21.22).

Proposition 2.5.5 ([KLW87]). *If $A \subseteq 2^\omega$ is analytic and $A \cap B = \emptyset$ then one of the following holds,*

1. *there is F an F_σ set such that separates A from B or,*
2. *there is a perfect set $C \subseteq A \cup B$ such that $C \cap B$ is countable dense in C .*

With this we can easily prove the following.

Corollary 2.5.1. *If A is Borel and is not F_σ then \mathcal{I}_A is not P^+ (tree).*

Proof. If A is Borel but not F_σ then, by the Kechris-Louveau-Woodin theorem, there is a perfect set C such that $C \cap (2^\omega - A)$ is countable dense in C , which shows that \mathcal{I}_A is not P^+ (tree). \square

An alternative proof of the previous corollary would be to note that if A is Borel but not F_σ then \mathcal{I}_A will also be Borel but not F_σ , so it can not be P^+ (tree). The next result will give us an example of a non Canjar ideal that is P^+ (tree),

Proposition 2.5.6. *If B is Bernstein then \mathcal{I}_B is P^+ (tree) but not Canjar.*

Proof. Since the complement of a Bernstein set is Bernstein, it follows easily by the topological characterization of P^+ (tree) that \mathcal{I}_B is P^+ (tree). We will now show it is not Canjar. Build an increasing sequence $\langle \mathcal{C}_n : n \in \omega \rangle$ of compact sets in the following way,

1. we choose $b_0^0 \notin B$ and let $\mathcal{C}_0 = \{\widehat{b_0^0}\}$,
2. we choose $\langle b_n^{01} \rangle_{n \in \omega} \subseteq 2^\omega - B$ a convergent sequence to b_0^0 and define $\mathcal{C}_1 = \mathcal{C}_0 \cup \{\widehat{b_n^{01}} \mid n \in \omega\}$,

3. for every b_n^{01} we choose $\langle b_n^{012} \rangle_{n \in \omega} \subseteq 2^\omega - B$ a convergent sequence to b_n^{01} and define $\mathcal{C}_2 = \mathcal{C}_1 \cup \{\widehat{b_n^{012}} \mid n \in \omega\}$,

4. \vdots

It is clear that each $\mathcal{C}_n \subseteq \mathcal{I}_B^+$ and $\langle \mathcal{C}_n : n \in \omega \rangle$ forms an increasing sequence of compact sets. Let $\mathcal{P} = \{P_n \mid n \in \omega\}$ be a finite partition of $2^{<\omega}$ and define D as the set of all $x \in 2^\omega$ such that there is $\langle d_n \mid n \in \omega \rangle$ with the coherence property with respect to \mathcal{P} and $\widehat{x} \cap P_n = \widehat{d_n}$. It is easy to see that D is an uncountable closed set, so $B \cap D \neq \emptyset$ and hence \mathcal{I}_B is not Canjar. \square

Recall that a *Luzin set* is an uncountable set that has countable intersection with every meager set. Luzin sets exist under CH or after adding at least ω_1 Cohen reals. However, it is easy to see that the existence of a Luzin set implies that $\text{non}(\mathcal{M})$ is ω_1 , so their existence is not provable from ZFC. By a suitable modification of the previous argument, one can show the following.

Corollary 2.5.2. *If L is a (dense) Luzin set, then $\mathcal{I}_{\omega-L}$ is not Canjar.*

2.6 Open Questions

There are some questions we were unable to answer, probably the most interesting one is the following.

Problem 1. *Is there a Canjar MAD family? Is there one of cardinality continuum?*

We proved that if $\mathfrak{d} = \mathfrak{r} = \mathfrak{c}$ then there is a Canjar MAD family of size continuum, but we do not even know the answer to the following question.

Problem 2. *Does $\mathfrak{d} = \mathfrak{c}$ implies there is a Canjar MAD family?*

The characterization of Canjar ideals suggest the next questions.

Problem 3. *Are there coherent strong P^+ -ideals that are not strong P^+ ?*

We know there are P^+ -ideals that are not P^+ (tree), but we do not know the answer of the following question.

Problem 4. *Is there a Canjar ideal \mathcal{I} such that $\mathcal{I}^{<\omega}$ is not P^+ (tree)?*

These questions except the first one have recently been answered by Chodounský, Repovš, and Zdomsky, see [DCZ]

Chapter 3

Porous sets

In this chapter we will make use of finite arithmetic, so our notation regarding products of sets might be confusing. Only in this chapter, whenever we write n^m , we mean n^m as a natural number and not as a set of functions. If X, Y are sets, then ${}^Y X$ is the set of all functions from Y to X and ${}^{<\omega} X = \bigcup_{n \in \omega} {}^n X$. This exception for our notation will be exclusive to this chapter. The results of this chapter have already been submitted and accepted in [GHMC].

3.1 Introduction

In the literature there are different notions of porosity. We will enlist some of these notions:

Definition 3.1.1. *Given a metric space $\langle X, d \rangle$, a subset $A \subseteq X$ is*

- upper porous if for every $x \in A$ there is $\rho > 0$ and a sequence $r_n \rightarrow 0$ such that for every $n \in \omega$ there is $y_n \in X$ such that $B_{\rho \cdot r_n}(y_n) \subseteq B_{r_n}(x) \setminus A$,
- lower porous if for every $x \in A$ there exists $\rho_x > 0$ and $r_{0_x} > 0$ such that for any $0 \leq r \leq r_{0_x}$ there is $y \in X$ such that $B_{\rho_x \cdot r}(y) \subseteq B_r(x) \setminus A$,
- strongly porous if there is a $p > 0$ such that for any $x \in X$ and any $0 < r < p$, there is $y \in X$ such that $B_{p \cdot r}(y) \subseteq B_r(x) \setminus A$.

Observe that porous sets are nowhere dense sets. The notion of porosity in \mathbb{R} was already been used by A. Denjoy in [[Den41]], however the systematic study of porosity began in 1967 in [Dol67] and since then, many applications have been found ([PZ84] [BEH78], [LP03], [RZ01],

[Ren95] and [Zas01] for example). In this work, we will be interested in the study of cardinal invariants of the ideals generated by porous sets. In particular we are interested in comparing the different cardinal invariants of the σ -ideal generated by different notions of porosity (for example in [Bre96], [HZ12], [Rep89], [Rep90] and [Rep93]).

Denote by \mathbf{UP} the σ -ideal generated by upper-porous subsets of the real line. The cardinal invariants associated to the σ ideal \mathbf{UP} are studied in [Rep89], [Rep93] and in [Bre96]: In [Rep93], M. Repický proved that $\text{non}(\mathbf{UP}) \geq \mathfrak{m}_{\sigma\text{-centered}}$ and $\text{cov}(\mathbf{UP}) \leq \text{cof}(\mathcal{N})$ holds. He also proved ([Rep89]) that $\text{non}(\mathbf{UP}) \geq \text{add}(\mathcal{N})$ and in [Bre96], J. Brendle proved that $\text{add}(\mathbf{UP}) = \omega_1$ and $\text{cof}(\mathbf{UP}) = \mathfrak{c}$ holds. We are looking for analogies of these inequalities using the other notions of porosity.

It is easy to see that $A \subseteq X$ is upper/lower/strongly porous if and only if \bar{A} is upper/lower/strongly porous respectively. We will now show that, the notion of σ -lower porosity and σ -strong porosity coincide.

Proposition 3.1.1. *A subset $A \subseteq X$ is σ -strongly porous if and only if A is σ -lower porous.*

Proof. Clearly every strongly porous set is lower porous, so the only thing left to do is to show that every lower porous set is a σ -strongly porous set: let $A \subseteq X$ be a lower porous set. For each $n, m \in \mathbb{N}$, define

$$A_{n,m} = \{x \in A : \forall r \in (0, \frac{1}{m}) (\exists y \in X (B_{\frac{r}{n}}(y) \subseteq B_r(x) \setminus A))\}.$$

It is easy to see that $A = \bigcup_{n,m \in \mathbb{N}} A_{n,m}$, we have to show that each $A_{n,m}$ is a strongly porous set: let $x \in X$ and $r \in (0, 1)$, we will show that, for $\rho = \frac{1}{2nm}$, there is $y \in X$ such that $B_{\rho r}(y) \subseteq B_r(x) \setminus A$. There are two cases:

Case $r < \frac{1}{m}$. If $B_{\frac{1}{2n}}(x) \cap A_{n,m} = \emptyset$, then the conclusion follows easily. If not, then there is $a \in B_{\frac{1}{2n}}(x) \cap A_{n,m}$ so there is $y \in X$ such that $B_{\frac{r}{2n}}(y) \subseteq B_{\frac{r}{2}}(a) \setminus A_{n,m}$. Then we have that $B_{\rho r}(y) \subseteq B_{\frac{r}{2n}}(y) \subseteq B_{\frac{r}{2}}(a) \setminus A_{n,m} \subseteq B_r(x) \setminus A_{n,m}$. As a conclusion, for $\rho' = \frac{1}{2n}$, there is $y \in X$ such that $B_{\rho' r}(y) \subseteq B_r(x) \setminus A$.

Case $\frac{1}{m} \leq r < 1$. Using the previous case, we know that there is $y \in X$ such that $B_{\rho \cdot r}(y) = B_{\rho' \cdot \frac{r}{m}}(y) \subseteq B_{\frac{r}{m}}(x) \setminus A \subseteq B_r(x) \setminus A$ which is what we were looking for. \square

As a consequence, the notions of lower porosity and strong porosity generate the same σ -ideals, and therefore, the same cardinal invariants.

The notion we will use the most is the notion of strongly porous set. From now, whenever we write that a set is porous, we will mean that the set is strongly porous.

The study of porous sets from \mathbb{R} can be done studying the porous sets of ${}^\omega 2$ instead. We will also be interested in studying the following kind of porous sets.

Definition 3.1.2. *We will say that a set $A \subseteq {}^\omega 2$ is n -porous if for every $s \in <{}^\omega 2$ there is a $t \in {}^n 2$ such that $\langle s \hat{\ } t \rangle \cap A = \emptyset$.*

The connection between n -porous sets and porous sets is given by the following proposition.

Proposition 3.1.2. *A subset $A \subseteq {}^\omega 2$ is porous if and only if there is an $n \in \omega$ such that A is n -porous.*

Proof. (\Rightarrow). Let ρ be the witness for the strongly porous property and let $n \in \omega$ be such that $\frac{1}{2^n} < \rho$. We will see that A is n -porous: Let $s \in <{}^\omega 2$ and let $k = |s|$. Pick $x \in {}^\omega 2$ such that $x \upharpoonright k = s$. Use the property of ρ to find a $y \in {}^\omega 2$ such that $B_{\rho \cdot \frac{1}{2^k}}(y) \subseteq B_{\frac{1}{2^k}}(x) \setminus A$. Pick $t \in {}^n 2$ such that $s \hat{\ } t \sqsubseteq y$. It is easy to show that $\langle s \hat{\ } t \rangle \subseteq B_{\rho \cdot \frac{1}{2^k}}(y)$ and that $B_{\frac{1}{2^k}}(x) = \langle s \rangle$, therefore $\langle s \hat{\ } t \rangle \cap A = \emptyset$.

(\Leftarrow). Let $n \in \omega$ be such that A is n -porous and let $\rho = \frac{1}{2^{n+1}}$. We will show that for every $x \in X$ and any $r \in (0, 1)$, there is a $y \in X$ such that $B_{\rho \cdot r}(y) \subseteq B_r(x) \setminus A$: let $x \in X$ and let $r \in (0, 1)$. Pick the shortest $s \in <{}^\omega 2$ such that $s \sqsubseteq x$ and $\langle s \rangle \subseteq B_r(x)$. Let $t \in {}^n 2$ be such that $\langle s \hat{\ } t \rangle \cap A = \emptyset$ and let $y \in {}^\omega 2$ be such that $s \hat{\ } t \sqsubseteq y$. Then $B_{\rho \cdot r}(y) \subseteq \langle s \hat{\ } t \rangle \subseteq B_r(x) \setminus A$. \square

We are now ready to show that there is a natural connection between porous sets of \mathbb{R} and porous sets of ${}^\omega 2$.

Proposition 3.1.3. *Let $\varphi : {}^\omega 2 \rightarrow [0, 1]$ defined by $\varphi(f) = \sum_{i \in \mathbb{N}} \frac{f(i)}{2^i}$. Then $A \subseteq {}^\omega 2$ is porous if and only if $\varphi(A) \subseteq \mathbb{R}$ is porous.*

Proof. For each $k \in \omega$, let \mathcal{D}_k be the family of closed intervals contained in $[0, 1]$ of length $\frac{1}{2^k}$ of the form $[\frac{n}{2^k}, \frac{n+1}{2^k}]$ and let \mathcal{D}'_k be the family of open intervals contained in $[0, 1]$ of length $\frac{1}{2^k}$ of the form $(\frac{n}{2^k}, \frac{n+1}{2^k})$. It follows easily that a set $A \subseteq [0, 1]$ is strongly porous if and only if there is a $n \in \omega$ such that for every $k \in \omega$ and every $D' \in \mathcal{D}'_k$, it is possible to find $D \in \mathcal{D}_k$ such that $D \subseteq D' \setminus A$. To finish the proof observe that if $s \in {}^{<\omega}2$, then $T(\langle s \rangle) \in \mathcal{D}_{|s|}$ and if $D \in \mathcal{D}'_k$, then, for some $s \in {}^{<\omega}2$, $T^{-1}(D) \subseteq \langle s \rangle$. The proposition follows easily from these facts and from the proposition 3.1.2. \square

We will denote the σ -ideal generated by porous sets on ${}^\omega 2$ by \mathbf{SP} and by \mathbf{SP}_n the σ -ideal generated by n -porous sets. We will show that these are different σ -ideals.

Definition 3.1.3. A tree $T \subseteq {}^{<\omega}2$ is n -hyperperfect if for every $s \in T$ there is $t \in T$ such that $s \sqsubseteq t$ and, for every $\sigma \in {}^n 2$, $t \frown \sigma \in T$. A tree is hyperperfect if it is n -hyperperfect for every $n \in \omega$. A tree $T \subseteq {}^{<\omega}2$ is n -hyperperfect (hyperperfect) if there is an n -hyperperfect (hyperperfect) tree T such that $[T] = A$.

Observe that, if T is n -hyperperfect, then $[T] \notin \mathbf{SP}_n$. Likewise, if T is hyperperfect, then $[T] \notin \mathbf{SP}$. It is routine to construct, for each $n \in \omega$, an n -hyperperfect tree T such that $[T] \in \mathbf{SP}_{n+1}$. Also, it is easy to construct an hyperperfect tree T such that $[T] \in \mathcal{M} \cap \mathcal{N}$ and, as a consequence, $[{}^\omega 2]^\omega = \mathbf{SP}_1 \subsetneq \mathbf{SP}_2 \subsetneq \mathbf{SP}_3 \subsetneq \dots \subsetneq \mathbf{SP} \subsetneq \mathcal{M} \cap \mathcal{N}$.

Let \mathbb{HPP} be the collection of all hyperperfect trees ordered by inclusion. It is easy to see that this forcing adds a real which is not included in any old element of \mathbf{SP} . Another canonical forcing which adds a real which is not included in any old element of \mathbf{SP} is the forcing $\text{Borel}({}^\omega 2)/\mathbf{SP}$. In [HZ12], the authors proved that these two forcings are equivalent. We will prove it below:

Proposition 3.1.4. Let $B \subseteq {}^\omega 2$ be a Borel set, then either B contains the branches of an hyperperfect set or $B \in \mathbf{SP}$.

Proof. Let $B \subseteq {}^\omega 2$ be a Borel subset. Consider the following game:

I	s_0		s_1		s_2		\dots
II		t_0		t_1		t_2	\dots

where each $s_i \in {}^{<\omega}2$ and each $t_i \in {}^i2$. The second player wins if and only if $s_0 \hat{\ } t_0 \hat{\ } s_1 \hat{\ } t_1 \hat{\ } s_2 \hat{\ } t_2 \hat{\ } \dots \notin B$. We will now prove the following claims.

Claim 3. *If the first player has a winning strategy, then there is an hyperperfect tree T such that $[T] \subseteq B$.*

Proof. Let σ be a winning strategy for the first player. Recursively define a tree T using the following rule: if \bar{x} is a possible finite play $\langle s_0, t_0, s_1, t_1, \dots, s_n, t_n \rangle$ where the first player is following σ and the second player was the last player who played, then, for each $t \in {}^{n+1}2$, $s_0 \hat{\ } t_0 \hat{\ } s_1 \hat{\ } t_1 \hat{\ } \dots \hat{\ } s_n \hat{\ } t_n \hat{\ } \sigma(\bar{x}) \hat{\ } t \in T$. Clearly T is an hyperperfect tree and each branch of T corresponds to a game where the first player was following σ , therefore $[T] \subseteq B$. \square

Claim 4. *If the second player has a winning strategy, then there is $S \in \mathbf{SP}$ such that $B \subseteq S$.*

Proof. Let σ be a winning strategy for the second player. For each \bar{x} , a possible finite play $\langle s_0, t_0, s_1, t_1, \dots, s_n \rangle$ where the second player is following σ and the first player was the last player who played, recursively define $T_{\bar{x}}$ as follows:

- for all $t \in {}^n2$ such that $t \neq \sigma(\bar{x})$, $s_0 \hat{\ } t_0 \hat{\ } s_1 \hat{\ } t_1 \hat{\ } \dots \hat{\ } s_n \hat{\ } t \in T_{\bar{x}}$.
- if $\sigma \in T_{\bar{x}}$ and s is such that $\sigma = s_0 \hat{\ } i_0 \hat{\ } s_1 \hat{\ } i_1 \hat{\ } \dots \hat{\ } t_{n-1} \hat{\ } s$, then there is an $t \in {}^n2$ such that, $\langle s_0, t_0, s_1, t_1, \dots, t_{n-1}, s, t \rangle$ is a legal play where the second player is following σ . For all $\tau \in {}^n2$ such that $\tau \neq t$, $\sigma \hat{\ } \tau \in T_{\bar{x}}$.

Clearly, for each legal play \bar{x} where the second player is following σ , $T_{\bar{x}}$ is an n porous tree. We will show that, for every $f \in B$, there is a legal play \bar{x} where the second player is following σ such that $f \in [T_{\bar{x}}]$: Suppose this is not the case, then we have that $f \notin T_{\langle \emptyset \rangle}$, so there must be an $s \in {}^{<\omega}2$ and $t_0 \in 2^0$ such that the play $\bar{x}_0 = \langle s_0, t_0 \rangle$ is a play where the second player is following σ and $s_0 \hat{\ } t_0 \sqsubseteq f$. Recursively, using this idea, it is possible to find $\bar{x}_n = \langle s_0, t_0, s_1, t_1, \dots, s_n, t_n \rangle$ such that \bar{x}_n is a play where the second player is following σ and $s_0 \hat{\ } t_0 \hat{\ } \dots \hat{\ } s_n \hat{\ } t_n \sqsubseteq f$. Let $\bar{x} = \langle s_0, t_0, s_1, t_1, \dots \rangle$, then \bar{x} is a play where the second player is following σ , therefore $f = s_0 \hat{\ } t_0 \hat{\ } \dots \notin B$ which is a contradiction. \square

The conclusion follows from the previous claims and the Borel determinacy theorem. \square

As a consequence of this proposition, the forcing \mathbb{HIP} is forcing equivalent with $\text{Borel}^{(\omega 2)}/\text{SP}$ which has been thoroughly studied in Zapletal's book [Zap08]. Recall that M. Repický proved that $\text{cov}(\text{UP}) \leq \text{cof}(\mathcal{N})$ holds. It is natural to ask if it is possible to have the same inequality for the σ -ideal of porous sets of the real line (equivalently, for the σ -ideal of lower porous sets of the real line). In [HZ12], the authors proved that this is not the case; they proved that there is a model where the inequality $\text{cov}(\text{UP}) > \text{cof}(\mathcal{N})$ holds. For the convenience of the readers we will prove this in the next few pages. We will need the following theorems. Recall that a forcing \mathbb{P} has the *Sacks property* if for every \mathbb{P} name \dot{f} of a function of ω into ω and every $p \in \mathbb{P}$ there are an increasing function $g : \omega \rightarrow \omega$, a $q \leq p$ and a sequence $\{I_n : n \in \omega\}$ of finite subsets of ω such that, for every $n \in \omega$, $|I_n| \leq g(n)$ and $q \Vdash \dot{f} \in \prod_{n \in \omega} I_n$.

Theorem 3.1.1. *The forcing \mathbb{HIP} has the Sacks Property*

Proof. The proof is an usual fusion argument: Let \dot{f} be a \mathbb{P} -name of a function of ω into ω and let $T \in \mathbb{HIP}$. It may be the case that there is $S \leq T$ such that $S \Vdash \dot{f} \in V$. In such case, the conclusion follows trivially, so we will assume that this will not happen. Given $S \leq T$, define s_S as the longest initial segment of \dot{f} decided by S (by our assumption, this is a finite segment). Given $t \in S$, define

$$S_t = \{s \in {}^\omega 2 : s \subseteq t \vee t \subseteq s\}$$

It is clear that S_t is an hyperperfect tree such that $S_t \leq S$. Let $c : \omega \rightarrow \omega$ such that $c^{-1}(n)$ is infinite for every $n \in \omega$. Recursively we will define $\{t_\sigma \in T : \sigma \in \bigcup_{n \in \omega} \prod_{i < n} {}^{c(i)} 2\}$ and $\{S(\sigma) : \sigma \in \bigcup_{n \in \omega} \prod_{i < n} {}^{c(i)} 2\}$ with the following properties:

1. For all σ , $S(\sigma)$ is an hyper-perfect tree, $t_\sigma \in S(\sigma)$ and $S(\sigma) \leq T$,
2. For all σ and for all $\tau \in {}^{c(|\sigma|)} 2$, $t_\sigma \hat{\ } \tau \subseteq t_{\sigma \hat{\ } \tau}$ and $S(\sigma \hat{\ } \tau) \leq S(\sigma)$,
3. For all σ , and for all $\tau \in {}^{c(|\sigma|)} 2$, $\text{stem}(S(\sigma)_{t_\sigma}) \hat{\ } \tau \in S(\sigma)_{t_\sigma}$,
4. For all σ , $s_{S(\sigma)} > |\sigma|$.

The construction is not complicated: Let $t_\emptyset \in T$ be such that for all $\tau \in {}^1 2$, $\text{stem}(T_{t_\emptyset}) \hat{\ } \tau \in T$ (so $S(\emptyset) = T_{t_\emptyset}$), and if t_σ and $S(\sigma)$ has already been constructed, pick $S(\sigma \hat{\ } \langle \tau \rangle) \leq S(\sigma)$ so that $t_{\sigma \hat{\ } \langle \tau \rangle} \in S(\sigma \hat{\ } \langle \tau \rangle)$ and it decides a little more about f and pick $t_{\sigma \hat{\ } \langle \tau \rangle}$ so that 3 is satisfied.

To finish the proof, let T' be the tree generated by $\{t_\sigma \in T : \sigma \in \bigcup_{n \in \omega} \prod_{i < n} {}^{c(i)} 2\}$: 3 implies that T' is an hyperperfect tree, 1 implies that $T' \leq T$ and 1 and 2 implies that, for every $\sigma \in \bigcup_{n \in \omega} \prod_{i < n} {}^{c(i)} 2$, $T'_{t_\sigma} \leq S(\sigma)$. Then, if I_n is the set of all values of $\dot{g}(n)$ decided (property 4) by $S(\sigma)$ such that $\sigma \in \prod_{i < n} {}^{c(i)} 2$, we have that $|I_n|$ is finite and $T' \Vdash \text{``}\dot{g} \in \prod_{n \in \omega} I_n\text{''}$. \square

The forcing \mathbb{HP} has many interesting properties, which can be deduced from the theorems in [Zap08]: Observe that \mathbb{SP} is generated by a σ -compact collection of compact sets: let $K_n = \{C \in \mathcal{C}(\omega_2) : C \text{ is an } n\text{-porous set}\}$, where $\mathcal{C}(\omega_2)$ is the hyperspace of closed sets of ω_2 with the usual Vietoris topology (see [Eng77] for a detailed introduction to this topic), then K_n is compact in $\mathcal{C}(\omega_2)$: given $C \notin K_n$, there is an $s \in {}^{<\omega_2}$ such that for every $t \in {}^n 2$, $\langle s \hat{\ } t \rangle \cap C \neq \emptyset$. If $\mathcal{U} = \{C \in \mathcal{C}(\omega_2) : \forall t \in {}^n 2 (\langle s \hat{\ } t \rangle \cap C \neq \emptyset)\}$, then \mathcal{U} is an open set such that $C \in \mathcal{U}$ and $\mathcal{U} \cap K_n = \emptyset$. Using the fact that $\mathcal{C}(\omega_2)$ is a compact space, we have that $\bigcup_{n \in \mathbb{N}} K_n$ is a σ -compact collection of compact sets, and \mathbb{SP} is generated by $\bigcup_{n \in \mathbb{N}} K_n$. From this we can deduce many properties of the forcing of hyperperfect trees. For example:

Theorem 3.1.2 ([Zap08]). *Suppose that the σ -ideal \mathcal{I} on a compact metric space X is generated by a σ -compact collection of compact sets. Then the forcing $\text{Borel}(X)/\mathcal{I}$ preserves the Baire category, is bounding and does not add splitting reals.*

Also, it can be shown that \mathbb{HP} preserves p -points. We are ready to prove the following theorem from [HZ12].

Theorem 3.1.3. *It is consistent that $\text{cov}(\mathbb{SP}) > \text{cof}(\mathcal{N})$.*

Proof. Let $\mathbb{P}_{\omega_2} = \langle \mathbb{P}_\alpha, \dot{Q}_\alpha \rangle_{\alpha \in \omega_2}$ be a countable support iteration such that for each α , $\mathbb{P}_\alpha \Vdash \text{``}\dot{Q}_\alpha = \mathbb{HP}\text{''}$. By a standard reflection argument, in $V[G] \models \text{cov}(\mathbb{SP}) = \aleph_2$. Using 3.1.1 and the perservation theorem of Sacks property (see [BJ95]), $V[G] \models \text{cof}(\mathcal{N}) = \aleph_1$. \square

Therefore, in this model $\aleph_1 = \text{non}(\mathbf{SP}_1) \leq \text{non}(\mathbf{SP}_2) \leq \text{non}(\mathbf{SP}_3) \leq \dots \leq \text{non}(\mathbf{SP}) \leq \text{non}(\mathcal{M}) = \aleph_1$ and that $\mathfrak{c} = \text{cov}(\mathbf{SP}_1) \geq \text{cov}(\mathbf{SP}_2) \geq \text{cov}(\mathbf{SP}_3) \geq \dots \geq \text{cov}(\mathbf{SP}) = \mathfrak{c}$. In the following section we will show a way to separate these inequalities. We will also uncover a relationship between these cardinal invariants and the Martin numbers for σ - k -linked forcings.

Given $k \in \omega$ and a forcing notion \mathbb{P} a subset $A \subseteq \mathbb{P}$ is k -linked if for every collection $\{a_i : i \in k\}$ of k elements of A , there is an $a \in \mathbb{P}$ stronger than each a_i , that is, for every $i \in k$, $a \leq a_i$. \mathbb{P} is σ - k -linked if \mathbb{P} is the countable union of k -linked subsets of \mathbb{P} . We will denote \mathfrak{m}_k the *Martin number for σ - k -linked forcings*, that is, the smallest cardinal κ such that there is a σ - k -linked forcing \mathbb{P} and κ \mathbb{P} -dense subsets of \mathbb{P} such that no filter of \mathbb{P} intersects them all.

3.2 The Additivity and the Cofinality number.

Recall that J. Brendle (in [Bre96]) proved that $\text{add}(\mathbf{UP}) = \omega_1$ and $\text{cof}(\mathbf{UP}) = \mathfrak{c}$. In [HZ12], the authors asked if this inequality holds for the σ -ideal generated by porous sets of the real line. The main goal of this section is to prove that $\text{add}(\mathbf{SP}) = \omega_1$ and $\text{cof}(\mathbf{SP}) = \mathfrak{c}$. We will use the following notion.

Definition 3.2.1. Let $k \in \omega$. A tree $T \subseteq {}^{<\omega}2$ is a k -porous tree if for every $s \in {}^{<\omega}2$ there is $t \in {}^k2$ such that $s \hat{\ } t \notin T$.

Note that $A \subseteq {}^\omega 2$ is k -porous if and only if there is a k -porous tree T such that $[T]$ contains A .

Theorem 3.2.1. There is a family $\{T_f : f \in {}^\omega 2\}$ of 2-porous trees such that for every $X \in \mathbf{SP}$, the set $\{f \in {}^\omega 2 : [T_f] \subseteq X\}$ is countable.

Proof. We will construct the family $\{T_f : f \in {}^\omega 2\}$ as follows: For every $a \subseteq {}^{<\omega}2$ such that $|a| = 2^n$, let $\varphi_a : a \rightarrow {}^n 2$ be a bijective function. For every $i \in \omega$, let $\psi_i : \{a \subseteq {}^i 2 : \exists k \in \omega (|a| = 2^k)\} \rightarrow \omega \setminus \{0\}$ be an injective function. If $a \subseteq {}^i 2$ and $|a| = 2^k$, define

$$\sigma_a = \langle 0, \underbrace{1, \dots, 1}_{2\psi_i(a) \text{ times}}, 0 \rangle.$$

For each $\sigma \in {}^{<\omega}2$, we will recursively define a finite tree T_σ as follows: $T_\emptyset = \{\emptyset\}$ and if T_σ is defined, then

$$T_{\sigma \hat{\ } i} = \{s \in {}^{<\omega}2 : \exists t \in \text{end}(T_\sigma) (\exists j \in \omega (\exists a \subseteq {}^{|\sigma|+1}2 \\ (|a| = 2^j \wedge \sigma \hat{\ } i \in a \wedge s \sqsubseteq t \hat{\ } \sigma_a \hat{\ } \varphi_a(\sigma \hat{\ } i))))\} \cup \{s \in {}^{<\omega}2 : \\ \exists t \in \text{end}(T_\sigma) (s \sqsubseteq t \hat{\ } \langle 1, 1 \rangle)\}.$$

This tree can be described using a picture: for each end node of T_σ and for each $a \subseteq {}^{|\sigma|+1}2$ such that the cardinality of a is a power of 2 and $\sigma \hat{\ } i \in a$, the following structure is added to the tree $T_{\sigma \hat{\ } i}$:

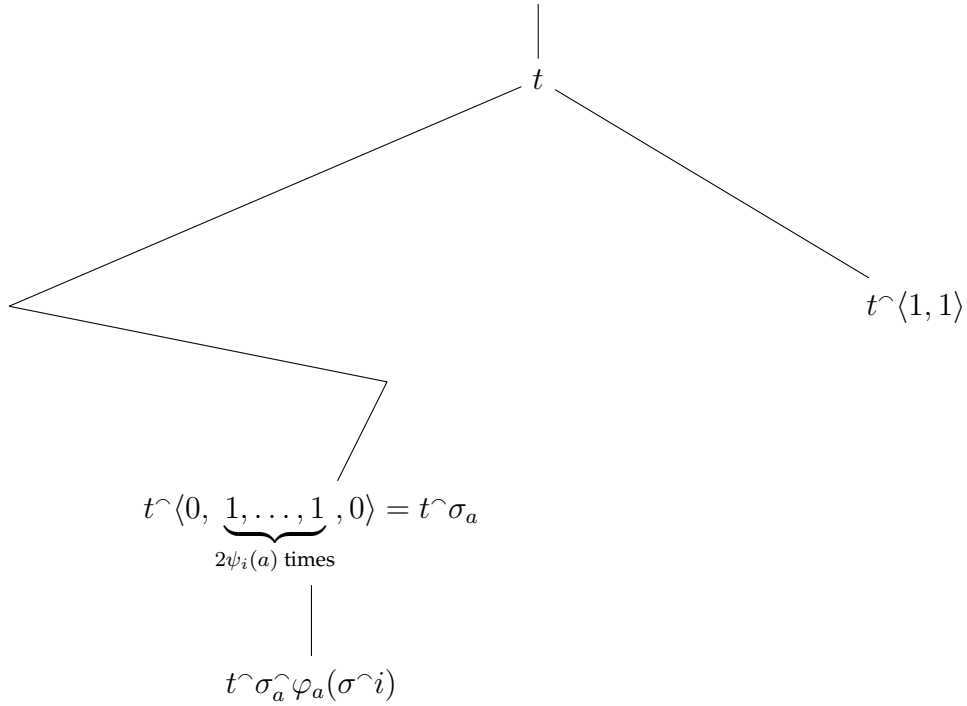

FIGURE 3.1: The tree T_σ with a fixed a

Observe that, for each $\sigma \in {}^{<\omega}2$, T_σ is a finite 2-porous tree: if s is a splitting point of T_σ (s is either an end node of the previous step or s is an end node concatenated with one zero and an even amount of ones), then $s \hat{\ } \langle 1, 0 \rangle \notin T_\sigma$. It is clear that, if $\sigma \sqsubseteq \tau$, then $T_\sigma \subseteq T_\tau$. For each $f \in {}^\omega 2$, define $T_f = \bigcup_{n \in \omega} T_{f \upharpoonright n}$. It follows easily that each T_f is a 2-porous tree.

We will show that the family $\{T_f : f \in {}^\omega 2\}$ is the family we were looking for: Let $X \in \text{SP}$. Without loss of generality we will assume that $X = \bigcup_{i \in \omega} [T_i]$, where T_i is an $i+1$ -porous tree. We must show that the set

$B = \{f \in {}^\omega 2 : [T_f] \subseteq X\}$ is countable: For each $s, t \in {}^{<\omega} 2$ and each $n \in \omega$, define $B_{s,t,n} = \{f \in {}^\omega 2 : t \sqsubseteq f, s \in T_t \wedge [T_f] \cap \langle s \rangle \subseteq [T_n]\}$. We will see that $B \subseteq \bigcup_{s,t \in {}^{<\omega} 2, n \in \omega} B_{s,t,n}$: If f is such that $f \in B$, then $[T_f] \subseteq \bigcup_{n \in \omega} [T_n]$. Using the Baire Category Theorem we can find $s \in T_f$ and $n \in \omega$ such that $[T_f] \cap \langle s \rangle \subseteq [T_n]$. Find $k \in \omega$ such that $s \in T_{f \upharpoonright k}$. It follows that $f \in B_{s, f \upharpoonright k, n}$. To finish the proof we will see that each $B_{s,t,n}$ has at most $2^{n+1} - 1$ elements: Suppose this is not the case and let $s, t \in {}^{<\omega} 2, n \in \omega$ and $\{f_i\}_{i < 2^{n+1}} \subseteq B_{s,t,n}$. Extend s to σ such that $\sigma \in \text{end}(T_t)$. Let $j \in \omega$ be such that the set $a = \{f_i \upharpoonright j : i < 2^{n+1}\}$ has 2^{n+1} elements and let

$$s_0 = \sigma \widehat{\langle \underbrace{1, \dots, 1}_{2 \cdot (j - |t| - 1) \text{ times}} \rangle} \sigma_a.$$

The tree T_n is $n + 1$ -porous, so there is a $\tau \in 2^{n+1}$ such that $s_0 \widehat{\tau} \notin T_n$. Find $k < 2^{n+1}$ such that $\varphi_a(f_k \upharpoonright j) = \tau$ and observe that $s_0 \widehat{\tau} = s_0 \widehat{\varphi_a(f_k \upharpoonright j)} \in T_{f_k}$. As a consequence, $[T_{f_k}] \cap \langle s \rangle \not\subseteq [T_n]$, but this contradicts the fact that $f_k \in B_{s,t,n}$. This implies that each $B_{s,t,n}$ is finite, and therefore B is countable. \square

We can now prove the main result of this section.

Corollary 3.2.1. $\text{add}(\text{SP}) = \omega_1, \text{cof}(\text{SP}) = \mathfrak{c}$.

Proof. Let $\{T_f : f \in {}^\omega 2\}$ be the family given by the theorem above. If $H \subseteq {}^\omega 2$ is an uncountable set, then the set $\bigcup\{[T_f] : f \in H\} \notin \text{SP}$. As a consequence, $\text{add}(\text{SP}) = \omega_1$. On the other hand, if $\kappa < \mathfrak{c}$ and if $\{X_\alpha : \alpha < \kappa\} \subseteq \text{SP}$, then there is an $f \in {}^\omega 2$ such that, for every $\alpha < \kappa$, $[T_f] \not\subseteq X_\alpha$ and therefore $\text{cof}(\text{SP}) = \mathfrak{c}$. \square

Observe that this last proof can be used to show that $\text{add}(\text{SP}_n) = \omega_1 = \text{add}(\text{SP})$ and $\text{cof}(\text{SP}_n) = \mathfrak{c} = \text{cof}(\text{SP})$. This answers a question from [HZ12].

3.3 Sacks forcing and anti-Sacks trees

Recall that a tree $T \subseteq {}^{<\omega} 2$ is a Sacks tree if $[S]$ is a nonempty perfect subset of ${}^\omega 2$. In other words, a tree $T \subseteq {}^{<\omega} 2$ is a *Sacks tree* if $T \neq \emptyset$ and for every $s \in T$, there is $t \in T$ such that $s \sqsubseteq t$ and both $t \frown 0, t \frown 1$ are nodes

of the tree T . The *Sacks forcing* \mathbb{S} is defined as the set of all Sacks trees ordered by inclusion; stronger trees are the smaller ones. This forcing is equivalent to the forcing $\text{Borel}^{(\omega 2)}/[\omega 2]^\omega$.

A generalization of the notion of Sacks tree can be seen in trees in ${}^{<\omega}k$. A tree $T \subseteq {}^{<\omega}k$ is a k -Sacks tree if $T \neq \emptyset$ and for every $s \in T$, there is $t \in T$ such that $s \sqsubseteq t$ and both $t \hat{\ }^i \in T$ for every $i \in k$. The k -Sacks forcing \mathbb{S}_k is defined as the set of all k -Sacks trees ordered by inclusion. There is a natural σ -ideal \mathcal{I} such that the k -Sacks forcing is equivalent to $\text{Borel}^{(\omega k)}/\mathcal{I}$. More information about this forcing can be found in [NR93].

Definition 3.3.1. Let $k \in \omega$. A tree $T \subseteq {}^{<\omega}k$ is a k -anti-Sacks tree if for every $s \in T$ there is $i < k$ such that $s \hat{\ }^i \notin T$. We will denote by \mathbf{AS}_k the σ -ideal generated by the branches of k anti-Sacks trees.

This notion corresponds to the analogue of the notion of 1-porous tree in ${}^{<\omega}k$. For example, the notion of 2-anti-Sacks tree is the same as being a single branch. The branches of a k -anti-Sacks tree form a nowhere dense set, so the σ -ideal generated by the branches of k -anti-Sacks trees \mathbf{AS}_k is a proper ideal. This ideal is closely related to the k -Sacks forcing:

Proposition 3.3.1. Let $B \subseteq {}^\omega k$ be a Borel set. Then either there is a countable collection of k -anti-Sacks trees $\{T_n\}_{n \in \omega}$ such that $B \subseteq \bigcup_{n \in \omega} [T_n]$ or there is a k -Sacks tree T such that $[T] \subseteq B$.

Proof. Let $B \subseteq {}^\omega k$ be a Borel subset. Consider the following game:

<i>I</i>	s_0		s_1		s_2		...
<i>II</i>		i_0		i_1		i_2	...

where each $s_j \in {}^{<\omega}k$ and each $i_j \in k$. The second player wins if and only if $s_0 \hat{\ }^{i_0} s_1 \hat{\ }^{i_1} s_2 \hat{\ }^{i_2} \dots \notin B$. We will need the following two claims.

Claim 5. If the first player has a winning strategy, then there is a k -Sacks tree T such that $[T] \subseteq B$.

Proof. Let σ be a winning strategy for the first player and recursively define T using the following rule: if \bar{x} is a possible finite play $\langle s_0, i_0, s_1, i_1, \dots, s_n, i_n \rangle$ where the first player is following σ and the second player was the

last player who played, then, for each $i \in k$, $s_0 \hat{i}_0 s_1 \hat{i}_1 \dots \hat{s}_n i_n \sigma(\bar{x}) \hat{i}$ $\in T$. Clearly T is a k -Sacks tree and each branch of T corresponds to a game where the first player was following σ , therefore $[T] \subseteq B$. \square

Claim 6. *If the second player has a winning strategy, then there is a countable collection of k -anti-Sacks trees $\{T_n\}_{n \in \omega}$ such that $B \subseteq \bigcup_{n \in \omega} [T_n]$.*

Proof. Let σ be a winning strategy for the second player. For each \bar{x} , a possible finite play $\langle s_0, i_0, s_1, i_1, \dots, s_n \rangle$ where the second player is following σ and the first player was the last player who played, recursively define $T_{\bar{x}}$ as follows:

- for all $i \in k$ such that $i \neq \sigma(\bar{x})$, $s_0 \hat{i}_0 s_1 \hat{i}_1 \dots \hat{s}_n i \in T_{\bar{x}}$.
- if $s \in T_{\bar{x}}$ and t is such that $s = s_0 \hat{i}_0 s_1 \hat{i}_1 \dots \hat{t}$, then there is an $n \in k$ such that, $\langle s_0, i_0, s_1, i_1, \dots, t, n \rangle$ is a legal play where the second player is following σ . For all $i \neq n$, $s \hat{i} \in T_{\bar{x}}$.

Clearly, for each legal play \bar{x} where the second player is following σ , $T_{\bar{x}}$ is a k -anti Sacks tree. We will show that, for every $f \in B$, there is a legal play \bar{x} where the second player is following σ such that $f \in T_{\bar{x}}$: Suppose this is not the case, then we have that $f \notin T_{\langle \emptyset \rangle}$, so there must be an $s \in {}^{<\omega}k$ and $i \in k$ such that the play $\bar{x}_0 = \langle s_0, i_0 \rangle$ is a play where the second player is following σ and $s_0 \hat{i}_0 \sqsubseteq f$. Recursively using this method, it is possible to find $\bar{x}_n = \langle s_0, i_0, s_1, i_1, \dots, s_n, i_n \rangle$ such that \bar{x}_n is a play where the second player is following σ and $s_0 \hat{i}_0 \dots \hat{s}_n i_n \sqsubseteq f$. Let $\bar{x} = \langle s_0, i_0, s_1, i_1, \dots \rangle$, then \bar{x} is a play where the second player is following σ , therefore $f = s_0 \hat{i}_0 \dots \notin B$. This is a contradiction. \square

The conclusion follows from the previous claims and from the Borel determinacy theorem. \square

Using this last proposition, it is easy to see that the k -Sacks forcing is forcing equivalent to $\text{Borel}({}^\omega k) / \text{AS}_k$.

The ideals SP_k and AS_{2^k} share many properties. Many of the results in this work will concern about properties of the ideals AS_k that are also valid for the ideal SP_k , and the proofs for both ideals are almost the same.

We will study the cardinal invariants of the ideal of porous sets using the anti-Sacks ideals.

Using a similar argument to the ones we gave in the last section, it is possible to show that $\text{add}(\mathbf{AS}_k) = \omega_1$ and that $\text{cof}(\mathbf{AS}_k) = \mathfrak{c}$. Alternatively, a proof of this fact can be found in [NR93].

3.4 The uniformity number

Recall that M. Repicky proved that $\text{non}(\mathbf{UP}) \geq \text{add}(\mathcal{N})$. One of the goals of this section is to prove that this inequality does not necessarily hold for the ideal \mathbf{SP} ; we will show the consistency of $\text{non}(\mathbf{SP}) < \text{add}(\mathcal{N})$. We will also develop some of the tools that we are going to use in the next section. The reader might find convenient to know that the tools that we are going to develop in this section are going to be developed twice: one for the ideal \mathbf{SP}_k and the other one for the ideal \mathbf{AS}_k and the proofs for both of these ideals are similar (the only differences are going to be arithmetic) so the reader can read one part of the proof and safely assume that the other part is going to be similar. The reason for doing this is that we do not know how close the relationship between these ideals is. We will refer the reader to the section of questions at the end of this chapter for more details about this issue.

We will also be studying the relationship between porosity, the notion of anti-Sacks tree and σ -linked forcings. In [HZ12], the authors proved that there is no relation between the cardinals $\mathfrak{m}_{\sigma\text{-centered}}$ and $\text{non}(\mathbf{SP})$. However, there is a strong relationship between the cardinals $\text{non}(\mathbf{SP}_k)$ and the Martin number for σ -linked forcings. We will use this relationship to study the connections between the Martin numbers of σ - k -linked forcings: It is easy to see that $\mathfrak{m}_2 \leq \mathfrak{m}_3 \leq \dots$ and, for each $k > 1$, it is possible to get the consistency of $\mathfrak{m}_k < \mathfrak{m}_{k+1}$ by forcing with a finite support iteration of σ - $(k+1)$ -linked forcings over a model of CH. In [BS03], the authors constructed a model where all the cardinals of the form \mathfrak{m}_{2^k} are different. We will prove that $\mathfrak{m}_2^k \leq \text{non}(\mathbf{SP}_k)$ and that $\mathfrak{m}_k \leq \text{non}(\mathbf{AS}_k)$ and we will use these facts to construct a model where all the Martin numbers \mathfrak{m}_i are different at the same time. In this model, the

cardinals $\text{non}(\mathbf{AS}_i)$ will be different all at once (so will be the cardinals $\text{non}(\mathbf{SP}_i)$).

The following notion can be stated in a very general context, however we will only state it for the case when the forcing is c.c.c. and the ideals are the ideal \mathbf{SP}_k and the ideal \mathbf{AS}_k . See [She98] for more details about this notion.

Definition 3.4.1. Let \mathbb{P} be a c.c.c. forcing notion and let $A \subseteq {}^\omega 2$ be such that $A \notin \mathbf{SP}_k$. We say that \mathbb{P} strongly preserves $\text{non}(\mathbf{SP}_k)$ in A if for every \mathbb{P} -name \dot{X} of a k -porous tree there is a $Y \in \mathbf{SP}_k$ such that, for every $x \in A$, if $x \notin Y$ then $\mathbb{P} \Vdash "x \notin [\dot{X}]"$. We will say that \mathbb{P} strongly preserves $\text{non}(\mathbf{SP}_k)$ if \mathbb{P} strongly preserves $\text{non}(\mathbf{SP}_k)$ in ${}^\omega 2$.

Definition 3.4.2. Let \mathbb{P} be a c.c.c. forcing notion and let $A \subseteq {}^\omega k$ be such that $A \notin \mathbf{AS}_k$. We say that \mathbb{P} strongly preserves $\text{non}(\mathbf{AS}_k)$ in A if for every \mathbb{P} -name \dot{X} of a k -anti-Sacks tree there is a $Y \in \mathbf{AS}_k$ such that, for every $x \in A$, if $x \notin Y$ then $\mathbb{P} \Vdash "x \notin [\dot{X}]"$. We will say that \mathbb{P} strongly preserves $\text{non}(\mathbf{AS}_k)$ if \mathbb{P} strongly preserves $\text{non}(\mathbf{AS}_k)$ in ${}^\omega k$.

It is easy to see that, if \mathbb{P} strongly preserves $\text{non}(\mathbf{AS}_k)$ in A , then $\mathbb{P} \Vdash "A \notin \mathbf{AS}_k"$ and if \mathbb{P} strongly preserves $\text{non}(\mathbf{AS}_k)$, then \mathbb{P} strongly preserves $\text{non}(\mathbf{AS}_k)$ in A for every $A \subseteq {}^\omega k$. We will now show that strongly preservation of $\text{non}(\mathbf{SP}_k)$ preserves the ground model as a non-porous set.

Lemma 3.4.1. Suppose that \mathbb{P} is a c.c.c. forcing notion such that it strongly preserves $\text{non}(\mathbf{SP}_k)$ for every $k > 0$, then $\mathbb{P} \Vdash "{}^\omega 2 \cap V \notin \mathbf{SP}"$.

Proof. Let $p \in \mathbb{P}$ and let $\{\dot{T}_n : n > 0\}$ be a collection of \mathbb{P} -names of trees such that $p \Vdash "\forall n > 0 (\dot{T}_n \text{ is a } n\text{-porous tree})"$. Then, by hypothesis, we can find a collection $\{Y_n : n \in \omega\}$ of subsets of ${}^\omega 2$ such that, for each $n > 0$, $Y_n \in \mathbf{SP}_n$ and if $x \notin Y_n$ then $p \Vdash "x \notin [\dot{T}_n]"$. Pick any $x \notin \bigcup_{n>0} Y_n$, then it follows that $p \Vdash "x \notin \bigcup_{n>0} [\dot{T}_n]"$ and therefore $\mathbb{P} \Vdash "{}^\omega 2 \cap V \notin \mathbf{SP}"$. \square

This last lemma is one of our main tools to solve Hrusak and Zindulka's question; we will now work with forcings that strongly preserve $\text{non}(\mathbf{SP}_k)$. It turns out that there is a well-known class of forcings with the property we desire. The next lemma shows that there is a connection between porous sets, anti-Sacks trees and σ - k -linked forcings.

Lemma 3.4.2. *Let \mathbb{P} be a forcing notion.*

1. *If \mathbb{P} is σ - k -linked, then \mathbb{P} strongly preserves \mathbf{AS}_k .*
2. *If \mathbb{P} is σ - 2^k -linked, then \mathbb{P} strongly preserves $\mathbf{non}(\mathbf{SP}_k)$.*

Proof. First we will prove 1. Let $\{\mathbb{P}_i : i \in \omega\} \subseteq \mathbb{P}$ be a sequence of k -linked subsets such that $\mathbb{P} = \bigcup_{i \in \omega} \mathbb{P}_i$. Let \dot{A} be a \mathbb{P} -name of a k -anti-Sacks tree. Define $T_n \subseteq {}^\omega k$ as follows:

$$T_n = \{s \in {}^{<\omega} k : \exists p \in \mathbb{P}_n (p \Vdash "s \in \dot{A}")\}.$$

We claim that, for each $n \in \omega$, T_n is a k -anti-Sacks tree. Suppose this is not the case, so there is an $s \in T_n$ such that, for every $i \in k$, $s \hat{\ } i \in T_n$. For every $i \in k$, we can pick a condition $p_i \in \mathbb{P}_n$ such that $p_i \Vdash "s \hat{\ } i \in \dot{A}"$. Let $p \in \mathbb{P}$ be such that, for every $i \in k$, $p \leq p_i$. Then $p \Vdash "\forall i \in k (s \hat{\ } i \in \dot{A})"$. This contradicts the fact that \dot{A} is a \mathbb{P} -name of a k -anti-Sacks tree.

To conclude the proof of 1, note that for every $x \in {}^\omega k$, if $p \Vdash "x \in [\dot{A}]"$, then $x \in [T_n]$, where n is such that $p \in \mathbb{P}_n$.

Now we will prove 2 using a similar method. Let $\{\mathbb{P}_i : i \in \omega\} \subseteq \mathbb{P}$ be a sequence of 2^k -linked subsets such that $\mathbb{P} = \bigcup_{i \in \omega} \mathbb{P}_i$. Let \dot{T} be a \mathbb{P} -name of a k -porous tree. Define $T_n \subseteq {}^\omega k$ as follows:

$$T_n = \{s \in {}^{<\omega} 2 : \exists p \in \mathbb{P}_n (p \Vdash "s \in \dot{T}")\}.$$

We claim that, for each $n \in \omega$, T_n is a k -porous tree. Suppose this is not the case, so there is an $s \in T_n$ such that, for every $i \in k$, $s \hat{\ } i \in T_n$. For every $i < k$, we can pick a condition $p_i \in \mathbb{P}_n$ such that $p_i \Vdash "s \hat{\ } i \in \dot{T}"$. Let $p \in \mathbb{P}$ be such that, for every $i < 2^k$, $p \leq p_i$. Then $p \Vdash "\forall i \in k (s \hat{\ } i \in \dot{T})"$. This contradicts the fact that \dot{T} is a \mathbb{P} -name of a k -porous tree.

To finish the proof of 2, note that for every $x \in {}^\omega 2$, if $p \Vdash "x \in [\dot{A}]"$, then $x \in [T_n]$, where n is such that $p \in \mathbb{P}_n$. \square

The lemma above is optimal in the sense that, for each k , there is a σ - $(k-1)$ -linked forcing \mathbb{P}_k such that $\mathbb{P}_k \Vdash "{}^\omega k \cap V \in \mathbf{AS}_k"$ and therefore \mathbb{P}_k does not strongly preserve \mathbf{AS}_k . Also, there is an example of a σ - (2^k-1) -linked forcing \mathbb{P}_k such that $\mathbb{P}_k \Vdash "{}^\omega 2 \cap V \in \mathbf{SP}_k"$, so the part

of $\text{non}(\text{SP}_n)$ is optimal too. We will show an example in the following pages.

We shall show that the property of strongly preserve $\text{non}(\text{AS}_k)$ (and strongly preserve $\text{non}(\text{SP}_k)$) is preserved along finite support iterations.

Lemma 3.4.3. *Let $\mathcal{I} \in \{\text{SP}_n, \text{AS}_k : n > 0, k > 1\}$ and let $A \subseteq {}^\omega k$ (with a suitable $k \in \omega$).*

1. *if \mathbb{P} is a forcing notion such that \mathbb{P} strongly preserves $\text{non}(\mathcal{I})$ in A and $\dot{\mathbb{Q}}$ is a \mathbb{P} -name for a forcing such that $\mathbb{P} \Vdash \text{“}\dot{\mathbb{Q}} \text{ strongly preserves } \text{non}(\mathcal{I}) \text{ in } A\text{”}$, then $\mathbb{P} * \dot{\mathbb{Q}}$ strongly preserves $\text{non}(\mathcal{I})$ in A ,*
2. *if $\langle \mathbb{P}_\alpha, \dot{\mathbb{Q}}_\alpha : \alpha \leq \gamma \rangle$ is a finite support iteration of c.c.c. forcings such that $\mathbb{P}_\alpha \Vdash \text{“}\dot{\mathbb{Q}}_\alpha \text{ strongly preserves } \text{non}(\mathcal{I}) \text{ in } A\text{”}$ for each $\alpha \in \gamma$, then \mathbb{P}_γ strongly preserves $\text{non}(\mathcal{I})$ in A .*

Proof. The part (1) is easy, we will only give a sketch of the proof: If \dot{X} is a $\mathbb{P} * \dot{\mathbb{Q}}$ -name for a k -anti-Sacks tree (or a k -porous tree), it is possible to find a collection $\{\dot{X}_n : n \in \omega\}$ of \mathbb{P} -names of k -anti-Sacks trees (or k -porous trees) such that, in the intermediate model, they are witnesses for $\mathbb{P} \Vdash \text{“}\dot{\mathbb{Q}} \text{ strongly preserves } \text{non}(\mathcal{I}) \text{ in } A\text{”}$. Using the strong preservation property a second time (now in V) for each \dot{X}_n will give us the conclusion we want.

We will proceed with part (2) by induction on γ . It is easy to see that the lemma holds for successor ordinals, and if γ has uncountable cofinality we can use a standard reflection argument to show that \mathbb{P} strongly preserves $\text{non}(\mathcal{I})$ in A , so it is enough to show that the lemma holds for $\gamma = \omega$: let \dot{T} be a \mathbb{P} -name of a k -anti-Sacks tree (or a k -porous tree). For each $n \in \omega$, let \dot{T}_n be a \mathbb{P}_n -name for the following set.

$$\dot{T}_n = \{s \in {}^{<\omega} k : \mathbb{P}_{(n,\omega)} \Vdash \text{“}s \in \dot{T}\text{”}\}.$$

It is easy to see that each \dot{T}_n is name for a k -anti-Sacks tree (or a k -porous tree). Now we use that each \mathbb{P}_n strongly preserves $\text{non}(\mathcal{I})$ to find a family $\{T_i^j : i, j \in \omega\}$ such that, for each $n \in \omega$, if $x \in A$ and $x \notin \bigcup_{i \in \omega} [T_i^n]$, then $\mathbb{P}_n \Vdash \text{“}x \notin [\dot{T}_n]\text{”}$. It is easy to see that the set $Y = \bigcup \{[T_i^j] : i, j \in \omega\}$ is the set we are looking for. \square

We will now prove the consistency of $\text{non}(\mathbf{SP}) < \text{add}(\mathcal{N})$. For constructing the model we are looking for, we will use the amoeba forcing \mathbb{A} in the following presentation:

$$\mathbb{A} = \{B \in \text{Borel}(2^\omega) : \mu(B) > \frac{1}{2}\}.$$

Here $\text{Borel}(2^\omega)$ represents the collection of Borel subsets of the Cantor space and μ is the standard Lebesgue measure over ${}^\omega 2$. The order is given by $A \leq B$ if and only if $A \subseteq B$. It is easy to see that any generic filter for \mathbb{A} codifies a closed set of measure $\frac{1}{2}$. We will now prove some properties of the amoeba forcing (these properties can also be found on [BJ95]).

Lemma 3.4.4. *The amoeba forcing is σ - n -linked for every $n \in \omega$.*

Proof. Let $n \in \omega$. For every clopen C in 2^ω , define

$$\mathbb{A}_C = \{A \in \mathbb{A} : \mu(C \setminus A) < \frac{1}{n} \cdot (\mu(C) - \frac{1}{2})\}$$

We will show that $\mathbb{A} = \bigcup \{\mathbb{A}_C : C \text{ is a clopen in } 2^\omega\}$: Let $A \in \mathbb{A}$ and let $\varepsilon > 0$ such that $\mu(A) = \frac{1}{2} + \varepsilon$. Find an open set $U \subseteq 2^\omega$ such that $A \subseteq U$ and $\mu(U \setminus A) < \frac{\varepsilon}{n}$. Now find a clopen set $C \subseteq U$ such that $\mu(C) > \frac{1}{2} + \varepsilon$. Then

$$\mu(C \setminus A) < \mu(U \setminus A) < \frac{\varepsilon}{n} = \frac{1}{n} \cdot (\frac{1}{2} + \varepsilon - \frac{1}{2}) < \frac{1}{n} \cdot (\mu(C) - \frac{1}{2}).$$

Therefore $A \in \mathbb{A}_C$. Now we must show that, for every clopen set $C \subseteq 2^\omega$, the intersection K of an arbitrary family $\{A_j : j \in n\} \subseteq \mathbb{A}_C$ is an element of \mathbb{A} . This is a consequence of the following calculations:

$$\mu(C) \leq \mu(K) + \sum_{j \in n} \mu(C \setminus A_j) < \mu(K) + \frac{1}{n} \cdot (\sum_{j \in n} \mu(C) - \frac{1}{2}) = \mu(K) + \mu(C) - \frac{1}{2}.$$

As a consequence, $\frac{1}{2} < \mu(K)$. Therefore $K \in \mathbb{A}$. \square

We will now see that the finite support iteration of length κ of the amoeba forcing increases $\text{add}(\mathcal{N})$ to κ . This is a consequence of the following lemma:

Lemma 3.4.5. $\mathbb{A} \Vdash \text{“}\bigcup(\mathcal{N} \cap V) \in \mathcal{N}\text{”}$.

Proof. Let $G \subseteq \mathbb{A}$ be a generic filter. Working in $V[G]$, for each $s \in {}^\omega 2$, let $G_s = \{s \hat{\ } A : A \in G\}$, where $s \hat{\ } A = \{s \hat{\ } f : f \in A\}$. Using genericity it is easy to see that, for each $s \in {}^\omega 2$, $\bigcap G_s \subseteq \langle s \rangle$, $\bigcap G_s$ is a closed set, $(\bigcup(\mathcal{N} \cap V)) \cap \bigcap G_s = \emptyset$ and $\mu(\bigcap G_s) = \frac{1}{2^{|s|+1}}$. We are ready to show that $\mu(\bigcup(\mathcal{N} \cap V)) = 0$. Let $\varepsilon > 0$. For each $n \in \omega$ we will find a sequence $s_0, s_1, \dots, s_{m_n} \in {}^{<\omega} 2$ with the following properties:

1. $\forall i, j < m_n (i \neq j \Rightarrow \langle s_i \rangle \cap \langle s_j \rangle = \emptyset)$,
2. $\forall n \in \omega \forall i \leq m_n (\bigcup_{k < n} \bigcup_{j < m_k} \bigcap G_{s_k}) \cup \langle s_i \rangle = \emptyset$,
3. $\sum_{i < m_n} \mu(\langle s_i \rangle) > \frac{1-\varepsilon}{2^n}$.

This can be easily done using induction and using the facts that the sets $\bigcap G_s$ are closed and $\mu(\bigcap G_s) = \frac{1}{2^{|s|+1}}$. Finally, observe that $\bigcup_{k \in \omega} \bigcup_{j < m_k} \bigcap G_{s_k}$ is an F_σ set disjoint with $(\bigcup(\mathcal{N} \cap V))$, and its measure is bigger than $1 - \varepsilon$, therefore the measure of $(\bigcup(\mathcal{N} \cap V))$ is smaller than ε . This is the conclusion we wanted. \square

We are ready to answer Hrusak and Zindulka's question. The method of the proof was suggested to us by J. Brendle.

Theorem 3.4.1. *If ZFC is consistent, then $\text{ZFC} + \text{non}(\mathbf{SP}) < \text{add}(\mathcal{N})$ is consistent.*

Proof. Start with a model V such that $V \models CH$. Let $\mathbb{P} = \{\mathbb{P}_\alpha, \dot{\mathbb{Q}}_\alpha : \alpha < \omega_2\}$ be a finite support iteration of the amoeba forcing. It follows from the lemmas 3.4.2, 3.4.3 and 3.4.4 that \mathbb{P} strongly preserves $\text{non}(\mathbf{SP}_k)$ for every $k \in \omega$ and therefore $\mathbb{P} \Vdash "2^\omega \cap V \notin \mathbf{SP}"$. As a consequence, we have that $V[G] \models \text{non}(\mathbf{SP}) = \omega_1$. A standard reflection argument and the lemma 3.4.5 implies that $V[G] \models \text{add}(\mathcal{N}) = \omega_2$, hence $V[G] \models \text{non}(\mathbf{SP}) < \text{add}(\mathcal{N})$. \square

Now we will focus on studying the Martin numbers for σ - k -linked forcings. In the Lemma 3.4.2 we already worked out a relationship between the σ -linked forcings, the porous sets and the anti-Sacks trees. We will now focus into constructing a class of examples that will show that the Lemma 3.4.2 is optimal. Given $k > 2$ let

$\mathbb{P}_k = \{\langle s, F \rangle : \begin{array}{l} \text{(a) } s \text{ is a } k\text{-anti-Sacks tree of height } \text{ht}(s), \\ \text{(b) } F \in [{}^\omega k]^{<\omega} \text{ and } \lceil F \upharpoonright \Delta_F \rceil \text{ is a finite } k\text{-anti-Sacks tree,} \\ \text{(c) } s \subseteq \lceil F \upharpoonright \Delta_F + 1 \rceil, \end{array}\}$

where $F \upharpoonright k = \{f \upharpoonright k : f \in F\}$, $\lceil F \rceil = \{s \in {}^{<\omega}k : \exists f \in F (s \subseteq f)\}$ and $\Delta_F = \min\{n \in \omega : |F \upharpoonright n| = |F|\}$. The order is defined by $\langle s', F' \rangle \leq \langle s, F \rangle$ if and only if $s \subseteq s'$ and $F \subseteq F'$. This forcing notion will be used to work with the ideal \mathbf{AS}_k . For the ideal \mathbf{SP}_k , we will be using a similar forcing notion. Given $k > 1$:

$\mathbb{P}_k = \{\langle s, F \rangle : \begin{array}{l} \text{(a) } s \text{ is a finite } k\text{-porous tree of height } \text{ht}(s), \\ \text{(b) } F \in [{}^\omega 2]^{<\omega}, \text{ and } \lceil F \upharpoonright \Delta_F \rceil \text{ is a finite } k\text{-porous tree,} \\ \text{(c) } s \subseteq \lceil F \upharpoonright \Delta_F + 1 \rceil. \end{array}\}$

The order is defined by $\langle s', F' \rangle \leq \langle s, F \rangle$ if and only if $s \subseteq s'$ and $F \subseteq F'$. The principal property of these forcings is that they destroy the non-porosity of the ground model:

Proposition 3.4.1. *Given a $k > 2$ and an $i > 1$, $\mathbb{P}_k \Vdash "{}^\omega k \cap V \in \mathbf{AS}_k"$ and $\mathbb{P}_i \Vdash "{}^\omega 2 \cap V \in \mathbf{SP}_i"$.*

Proof. First we will show that $\mathbb{P}_k \Vdash "{}^\omega k \cap V \in \mathbf{AS}_k"$: We will now show that, for every $f \in {}^\omega k$ and $n \in \omega$, the following sets are dense in \mathbb{P} :

$$D_f = \{\langle s, F \rangle \in \mathbb{P}_k : \exists \sigma \in {}^{<\omega}k (\sigma \frown (f \upharpoonright (\omega \setminus |\sigma|)) \in F)\},$$

$$E_n = \{\langle s, F \rangle \in \mathbb{P}_k : \Delta_F > n \wedge s = \lceil F \upharpoonright \Delta_F + 1 \rceil\}.$$

(D_f is dense): Let $\langle s, F \rangle \in \mathbb{P}_k$. Pick a σ in such a way that, if $F' = F \cup \{\sigma \frown (f \upharpoonright (\omega \setminus |\sigma|))\}$, $\lceil F' \upharpoonright \Delta'_F \rceil$ is a k -anti-Sacks tree. Then it follows that $\langle s, F' \rangle \in \mathbb{P}_k$ and $\langle s, F' \rangle \leq \langle s, F \rangle$.

(E_n is dense): Let $\langle s, F \rangle \in \mathbb{P}_k$ and let $f' = \chi_{\{n+\Delta_F+1\}}$ and pick any $f \in F$. It is easy to see that, if $F' = F \cup \{f + f'\}$, then $\langle \lceil F' \upharpoonright \Delta'_F + 1 \rceil, F' \rangle \in E_n$ and $\langle \lceil F' \upharpoonright \Delta'_F + 1 \rceil, F' \rangle \leq \langle s, F \rangle$.

If $G \subseteq \mathbb{P}_k$ is a filter meeting all these dense sets, then, using that the sets E_n are dense, it follows that $T = \bigcup \{s : \exists F (\langle s, F \rangle \in G)\}$ is a k -anti-Sacks tree. If $\sigma \in {}^{<\omega}k$ and if $C[\sigma] = \{\sigma \frown x \upharpoonright (\omega \setminus |\sigma|) : x \in [T]\}$, then, using that the D_f are dense, it follows that ${}^\omega k \cap V \subseteq \bigcup \{C[\sigma] : \sigma \in {}^{<\omega}k\} \in \mathbf{AS}_k$.

The proof of $\mathbf{P}_k \Vdash \text{“}\omega 2 \cap V \in \mathbf{SP}_k\text{”}$ is similar, the reader only has to replace every instance of the phrase k -anti-Sacks tree for k -porous tree, and replace every instance of \mathbb{P}_k for \mathbf{P}_k . \square

Note that the last proposition implies that \mathbb{P}_k does not have the strongly preservation of non(\mathbf{AS}_k) property and therefore, the Lemma 3.4.2 implies that \mathbb{P}_k is not σ - k -linked. A similar reasoning implies that \mathbf{P}_k is not σ - 2^k -linked. Contrasting this, we have the following proposition.

Proposition 3.4.2. *For each $k > 1$, \mathbb{P}_{k+1} is σ - k -linked and \mathbf{P}_k is σ - $(2^k - 1)$ -linked.*

Proof. First we will see that \mathbb{P}_{k+1} is σ - k -linked: For any two finite $(k+1)$ -anti-Sacks trees s, t of height $\text{ht}(s), \text{ht}(t)$ respectively, define

$$P(s, t) = \{\langle s, F \rangle \in \mathbb{P}_{k+1} : \text{ht}(t) > \Delta_F \wedge F \upharpoonright \text{ht}(t) = t\}.$$

It is easy to see that $\mathbb{P}_{k+1} = \bigcup \{P(s, t) : s, t \text{ are finite } (k+1)\text{-anti-Sacks trees}\}$. We will show that every $P(s, t)$ is k -linked: Let $\{\langle s, F_i \rangle : i < k\} \subseteq P(s, t)$ and let $F = \bigcup_{i < k} F_i$. We must show that $\langle s, F \rangle \in \mathbb{P}_{k+1}$. The properties **(a)** and **(c)** are easily verified, so the only thing left to do is to show that $[F \upharpoonright \Delta_F]$ is a $(k+1)$ -anti-Sacks tree: Let $\sigma \in [F \upharpoonright \Delta_F]$. If $|\sigma| < \text{ht}(t)$, then, because of $F \upharpoonright \text{ht}(t) = t$, it is possible to find an $i \in k$ such that $\sigma \wedge \langle i \rangle \notin [F \upharpoonright \Delta_F + 1]$. If $|\sigma| \geq \text{ht}(t)$, then, for every $i < k$, σ only has (at most) one immediate successor in F_i and therefore it is always possible to find a $j \in k$ such that $\sigma \wedge \langle j \rangle \notin [F \upharpoonright \Delta_F + 1]$.

The proof that \mathbf{P}_k is σ - $(2^k - 1)$ -linked is almost the same: For any two finite $(k+1)$ -porous trees s, t of height $\text{ht}(s), \text{ht}(t)$ respectively, define

$$P(s, t) = \{\langle s, F \rangle \in \mathbb{P}_{k+1} : \text{ht}(t) > \Delta_F + 2^n \wedge F \upharpoonright \text{ht}(t) = t\}.$$

It is easy to see that $\mathbb{P}_{k+1} = \bigcup \{P(s, t) : s, t \text{ are finite } k\text{-porous trees}\}$. We will show that every $P(s, t)$ is $(2^k - 1)$ -linked: Let $\{\langle s, F_i \rangle : i < 2^k - 1\} \subseteq P(s, t)$ and let $F = \bigcup_{i < 2^k - 1} F_i$. We must show that $\langle s, F \rangle \in \mathbb{P}_{k+1}$. The properties **(a)** and **(c)** are easily verified, so the only thing left to do is to show that $[F \upharpoonright \Delta_F]$ is a k -porous tree: Let $\sigma \in [F \upharpoonright \Delta_F]$. If $|\sigma| < \Delta_F$, then, because $F \upharpoonright \text{ht}(t) = t$, it is possible to find an $\tau \in {}^k 2$ such that $\sigma \wedge \tau \notin [F \upharpoonright \Delta_F + 1]$. If $|\sigma| \geq \text{ht}(t)$, then, for every $i < k$, σ only has (at

most) one immediate successor in F_i and therefore it is always possible to find a $\tau \in {}^k 2$ such that $\sigma \hat{\ } \tau [F \upharpoonright \Delta_F + 1]$. \square

From these last two propositions we get the following relation of cardinal invariants.

Corollary 3.4.1. *For each $k > 1$, $\mathfrak{m}_k \leq \text{non}(\mathbf{AS}_{k+1})$ and $\mathfrak{m}_{2^{k-1}} \leq \text{non}(\mathbf{SP}_k)$.*

Proof. This follows easily from the proof of the Proposition 3.4.1 and the last proposition. \square

Now we are going to focus into constructing a model where all the Martin numbers for σ -linked forcings are different at once. For achieving this, our main tool is going to be the theory of anti-Sacks trees that we developed in this work. In this model, all the cardinals of the form $\text{non}(\mathbf{AS}_k)$ are going to be pairwise different. Also, we can do it in such a way that the cardinals $\text{non}(\mathbf{SP}_k)$ are pairwise different too.

The strong preservation of $\text{non}(\mathbf{AS}_k)$ property is not always easy to get on ${}^\omega k$. Sometimes we will strongly preserve $\text{non}(\mathbf{AS}_k)$ on smaller sets with special properties. The following notion is going to be helpful for the proof of the main theorem.

Definition 3.4.3. *Given a regular cardinal κ and $\mathcal{I} \in \{\mathbf{SP}_n, \mathbf{AS}_k : n > 0, k > 1\}$, we will say that a set L is $\langle \kappa, \mathcal{I} \rangle$ -Luzin if $|L| = \kappa$ and $\mathcal{I} \upharpoonright L = [L]^{<\kappa}$.*

Observe that the existence of a $\langle \kappa, \mathcal{I} \rangle$ -Luzin set implies that $\text{non}(\mathcal{I}) \leq \kappa$. This kind of Luzin sets are going to help us to strongly preserve $\text{non}(\mathcal{I})$ in forcings with small cardinality.

One way to construct Luzin sets is using Cohen reals. Recall that Cohen reals are added at every limit step of countable cofinality of a finite support iteration of arbitrary length (see [BJ95]). We will use Cohen reals to construct $\langle \kappa, \mathcal{I} \rangle$ -Luzin sets.

Lemma 3.4.6. *Let κ be a regular cardinal, let $i > 2$, $k > 1$ and let $\mathbb{L} = \langle \mathbb{L}_\alpha, \dot{\mathbb{Q}}_\alpha : \alpha \in \kappa \rangle$ be a finite support iteration of length κ such that $\mathbb{L}_\alpha \Vdash \dot{\mathbb{Q}}_\alpha = \mathbb{P}_i * \mathbf{P}_k$, then*

$\mathbb{L} \Vdash \text{“There is a } \langle \kappa, \mathbf{AS}_i \rangle\text{-Luzin set and there is a } \langle \kappa, \mathbf{SP}_k \rangle\text{-Luzin set”}$.

Proof. Working in $V[G]$, let $L = \{f_\alpha : \alpha \in \kappa \wedge \alpha \text{ has countable cofinality}\}$ be a family of Cohen reals such that each f_α is added at the α -th stage of the iteration. Using the Proposition 3.4.1, it is easy to show that $V[G] \models [L]^{<\kappa} \subseteq \mathbf{AS}_i \upharpoonright L$. On the other hand, if $T \in V[G]$ is such that $V[G] \models T$ is an i -anti-Sacks tree, then, by a standard reflection argument, there is an intermediate model such that $T \in V[G(\beta)]$. As a consequence, $V[G] \models \forall \gamma > \beta (f_\gamma \notin [T])$. This implies that $V[G] \models \mathbf{AS}_i \upharpoonright L \subseteq [L]^{<\kappa}$. The $\langle \kappa, \mathbf{SP}_k \rangle$ -Luzin set is found in a similar way. \square

In the lemma above, it is clear that if we replace $\mathbb{L}_\alpha \Vdash \dot{\mathbb{Q}}_\alpha = \mathbb{P}_i * \mathbf{P}_k$ for $\mathbb{L}_\alpha \Vdash \dot{\mathbb{Q}}_\alpha = \mathbb{P}_i$, then, in the extension, we still have a $\langle \kappa, \mathbf{AS}_i \rangle$ -Luzin set (but we may not have a $\langle \kappa, \mathbf{SP}_k \rangle$ -Luzin set). The following theorem is the main tool we will use to construct the model where all the Martin numbers for σ -linked forcings are different.

Theorem 3.4.2. *If ZFC is consistent, then $\text{ZFC} + \forall i > 2 (\exists L_i (L_i \text{ is } \langle \aleph_i, \mathbf{AS}_i \rangle\text{-Luzin})) + \forall k > 1 (\exists L'_i (L'_i \text{ is } \langle \aleph_{2^k}, \mathbf{SP}_k \rangle\text{-Luzin}))$ is consistent.*

Proof. Let $\mathbb{L} = \langle \mathbb{L}_\alpha, \dot{\mathbb{Q}}_\alpha : \alpha \in \omega_\omega \rangle$ be a finite support iteration of length ω_ω such that, for each $i > 1$ and each $\alpha \in [\omega_i, \omega_{i+1})$, $\mathbb{L}_\alpha \Vdash \dot{\mathbb{Q}}_\alpha = \mathbb{P}_{i+1} * \mathbf{Q}_{i+1}$, where $\mathbf{Q}_{i+1} = \mathbf{P}_{i+1}$ when $i+1$ is a number of the form $2^k + 1$ and $\mathbf{Q}_{i+1} = \{\emptyset\}$ in all the other cases (for $\alpha < \omega_2$, $\mathbb{L}_\alpha \Vdash \dot{\mathbb{Q}}_\alpha = \{\emptyset\}$). We will show that the extension is the model we are looking for: We will show that there are $\langle \aleph_i, \mathbf{AS}_i \rangle$ -Luzin sets for every $i > 2$: Using the lemma above, for each $i > 2$, in $V[G_{\omega_i}]$ there is a $\langle \aleph_i, \mathbf{AS}_i \rangle$ -Luzin set L_i . The only thing left to do is to show that L_i remains $\langle \aleph_i, \mathbf{AS}_i \rangle$ -Luzin in $V[G]$. Using that \mathbb{L} is c.c.c. it is easy to see that, in $V[G]$, $[L_i]^{<\omega_i} \subseteq \mathbf{AS}_i \upharpoonright L_i$, so we only need to show that $\mathbf{AS}_i \upharpoonright L_i \subseteq [L_i]^{<\omega_i}$ holds in $V[G]$: First, using Lemma 3.4.2 and Lemma 3.4.3, we observe that $\mathbb{L}_{[\omega_i, \omega_\omega]}$ strongly preserves $\text{non}(\mathbf{AS}_i)$ in L_i , so if \dot{T} is a $\mathbb{L}_{[\omega_i, \omega_\omega]}$ -name of a i -anti-Sacks tree, then, in $V[G_{\omega_i}]$, there is a $X \in \mathbf{AS}_i \upharpoonright L_i$ such that $\mathbb{L}_{[\omega_i, \omega_\omega]} \Vdash \dot{T} \cap L_i \subseteq X$. Then it follows that $\mathbf{AS}_i \upharpoonright L_i \subseteq [L_i]^{<\omega_i}$ holds in $V[G]$. The proof that there are $\langle \aleph_{2^k}, \mathbf{SP}_k \rangle$ -Luzin sets is similar. \square

The actual value of \mathfrak{c} in the model above may depend on V . For example, if $V \models \text{GCH}$, then it is easy to see that $V[G] \models \mathfrak{c} = \aleph_{\omega+1}$. We will now see that small forcings preserve $\text{non}(\mathbf{AS}_k)$ and $\text{non}(\mathbf{SP}_k)$ in Luzin sets.

Lemma 3.4.7. *Let κ be a regular cardinal, let $\mathcal{I} \in \{\mathbf{SP}_n, \mathbf{AS}_k : n > 0, k > 1\}$ and let L be a $\langle \kappa, \mathcal{I} \rangle$ -Luzin. If \mathbb{P} is a forcing notion such that $|\mathbb{P}| < \kappa$, then \mathbb{P} strongly preserves $\text{non}(\mathcal{I})$ in L .*

Proof. We will do the case when $\mathcal{I} \in \{\mathbf{AS}_i : i > 1\}$, the other cases are similar: Let \dot{A} be a \mathbb{P} -name of an i -anti-Sacks tree and let $\mathbb{P} = \{p_\alpha : \alpha \in \mu\}$. For each $\alpha \in \mu$ define $T_\alpha = \{s \in {}^{<\omega}k : p_\alpha \Vdash "s \in \dot{A}"\}$. Observe that each T_α defines an i -anti-Sacks tree: if that is not the case, then p_α would force that \dot{A} is not an i -anti-Sacks tree. If $Y = \bigcup\{[T_\alpha] \cap L : \alpha \in \mu\}$ then $Y \in \mathbf{AS}_k$. If $x \in L$ and $p_\alpha \Vdash "x \in [\dot{A}]"$, then $x \in [T_\alpha] \cap L \subseteq Y$ and therefore \mathbb{P} strongly preserves $\text{non}(\mathbf{AS}_i)$ in L . \square

We will now construct the model we are looking for.

Theorem 3.4.3. *If ZFC is consistent, then $\text{ZFC} + \forall k > 1 (\mathfrak{m}_k = \text{non}(\mathbf{AS}_{k+1}) = \aleph_{k+1}) + \forall i > 1 (\mathfrak{m}_{2^i-1} = \text{non}(\mathbf{SP}_i) = \aleph_{2^i+1}) + \text{non}(\mathbf{SP}) = \aleph_{\omega+1}$ is consistent.*

Proof. Start with a model V like the one constructed in Theorem 3.4.2 and $V \models \mathfrak{c} = \aleph_{\omega+1}$. Using a standard bookkeeping argument (like the one that is used to construct a model for Martin's axiom), it is possible to construct a finite support iteration \mathbb{P} of length $\omega_{\omega+1}$ of σ - k -linked forcings of size smaller than \aleph_{k+1} (for every $k > 1$), such that any partial order which appears in an intermediate model is listed cofinally along the iteration. Now, using the lemmas 3.4.2, 3.4.3 and 3.4.7, it is possible to show that, for every $k > 2$, \mathbb{P} strongly preserves $\text{non}(\mathbf{AS}_k)$ in L_k . If $G \subseteq \mathbb{P}$ is a generic filter over V , then $V[G] \models \text{non}(\mathbf{AS}_k) \leq \aleph_k$. We note that, as each small σ - k -linked forcing appears in an intermediate model in the iteration, we have $V[G] \models \aleph_{k+1} \leq \mathfrak{m}_k$. As a consequence $V[G] \models \aleph_{k+1} = \mathfrak{m}_k = \text{non}(\mathbf{AS}_{k+1})$. Using a similar argument, it is possible to show that, for each $i > 1$, $V[G] \models \aleph_{2^i+1} = \mathfrak{m}_{2^i-1} = \text{non}(\mathbf{SP}_i)$. To finish the proof, use the fact that $\text{non}(\mathbf{SP})$ does not have countable cofinality and that, for every $n \in \omega$, $\text{non}(\mathbf{SP}_n) \leq \text{non}(\mathbf{SP})$ to show that $V[G] \models \text{non}(\mathbf{SP}) = \mathfrak{c} = \aleph_{\omega+1}$. \square

It follows from $\mathbf{SP}_1 \subseteq \mathbf{SP}_2 \subseteq \mathbf{SP}_3 \subseteq \dots$ that $\omega_1 = \text{non}(\mathbf{SP}_1) \leq \text{non}(\mathbf{SP}_2) \leq \text{non}(\mathbf{SP}_3) \leq \dots \leq \text{non}(\mathbf{SP})$ and we proved in the theorem above that each inequality can be consistently strict. It is important

to remark that none of these numbers is comparable with $\mathfrak{m}_{\sigma\text{-centered}}$: We already showed the consistency of $\text{non}(\mathbf{SP}_k) < \mathfrak{m}_{\sigma\text{-centered}}$. The argument for the other inequality can be found in [HZ12] and it goes as follows: Start with a model of $\mathfrak{m}_{2^k} = \omega_2+$ there is a Suslin tree, and force with the Suslin tree, then in the extension, $\mathfrak{m}_{\sigma\text{-centered}} = \omega_1$ but $\text{non}(\mathbf{SP}) = \omega_2$ (the Suslin tree does not add new reals). For more details about forcing with a Suslin tree see [Far96]. Clearly the same argument can be applied to $\text{non}(\mathbf{AS}_k)$.

3.5 The covering number

It follows from the fact that $\mathbf{AS}_2 \subseteq \mathbf{AS}_3 \subseteq \dots$ that $\text{cov}(\mathbf{SP}) \leq \dots \leq \text{cov}(\mathbf{AS}_3) \leq \text{cov}(\mathbf{AS}_2) = \mathfrak{c}$. We can show that every pair of these numbers can be consistently different.

Proposition 3.5.1. *Let $k > 1$, if ZFC is consistent, then $\text{ZFC} + \text{cov}(\mathbf{AS}_{k+1}) < \text{cov}(\mathbf{AS}_k)$ is consistent.*

Proof. Let V be a model such that $V \models \text{cov}(\mathbf{AS}_k) = \mathfrak{c} = \omega_2$ (for example, the Cohen model). Let \mathbb{P} be a finite support iteration of length ω_1 of the \mathbb{P}_{k+1} forcing defined in the last section and let $G \subseteq \mathbb{P}$ be a generic filter over V . It follows that \mathbb{P} is an iteration of σ - k -linked forcing notions and therefore \mathbb{P} strongly preserves $\text{non}(\mathbf{AS}_k)$. In $V[G]$, consider the family $C = \{V[G_\alpha] \cap {}^\omega(k+1) : \alpha < \omega_1\}$. Using Proposition 3.4.1, it is easy to show that $V[G] \models C \subseteq \mathbf{AS}_{k+1}$ and $V[G] \models \bigcup C = {}^\omega(k+1)$. As a consequence we have that $V[G] \models \text{cov}(\mathbf{AS}_{k+1}) = \omega_1$. On the other hand, if $\{T_\alpha : \alpha \in \omega_1\}$ is a collection of \mathbb{P} -names for k -anti-Sacks trees, then we can use the fact that \mathbb{P} strongly preserves $\text{non}(\mathbf{AS}_k)$ to show that there is a collection $\{C_\alpha : \alpha \in \omega_1\} \subseteq \mathbf{AS}_k$ such that if $x \in {}^\omega k$ and $x \notin \bigcup \{C_\alpha : \alpha \in \omega_1\}$, then $\mathbb{P} \Vdash "x \notin \bigcup_{\alpha \in \omega_1} [T_\alpha]"$. This, together with $V \models \text{cov}(\mathbf{AS}_k) > \omega_1$, implies that $V[G] \models \text{cov}(\mathbf{AS}_{k+1}) < \text{cov}(\mathbf{AS}_k)$. \square

Observe that a similar proposition the cardinals $\text{cov}(\mathbf{SP}_k)$ can be done using the forcings \mathbf{P}_k .

An alternative proof of this proposition follows from the results proven in [NR93]. If $k > 1$, then a tree $T \subseteq {}^{<\omega}\omega$ is a k -tree if every $s \in T$ has at most k immediate successors. A forcing notion \mathbb{P} has the k -localization

property if $\mathbb{P} \Vdash \text{“}\forall f \in {}^\omega\omega (\exists T \in V (T \text{ is a } k\text{-tree and } f \in [T]))\text{”}$. It is easy to see that if \mathbb{P} has the k -localization property, then $\mathbb{P} \Vdash \text{“}\bigcup(\mathbf{AS}_{k+1} \cap V) = {}^\omega k + 1\text{”}$. Let $\mathbb{S}_k = \{T \subseteq {}^{<\omega}k : \forall s \in T(\exists t \in T(\forall i \in k(s \sqsubseteq t \wedge t \hat{\ } i \in T)))\}$ be the k -Sacks forcing ordered by inclusion. It turns out that \mathbb{S}_k is forcing equivalent to $\text{Borel}({}^\omega k)/\mathbf{AS}_k$ and that if \mathbb{P} is the countable support iteration or the countable support product of length ω_2 of the forcing \mathbb{S}_k , then \mathbb{P} has the k -localization property (see [NR93]). As a consequence, in the extension $\text{cov}(\mathbf{AS}_{k+1}) = \omega_1$ and $\text{cov}(\mathbf{AS}_k) = \omega_2$.

3.6 Questions

We will finish this chapter with some questions about the cardinals of the ideals \mathbf{SP}_k . Obviously it is impossible to separate infinitely many of the $\text{cov}(\mathbf{SP}_n)$ at the same time. This suggests the following:

Question 1. *How many of the $\text{cov}(\mathbf{SP}_n)$ can be separated at the same time?*

We do not even know how to separate three of them. Another question we have is the following:

Question 2. *Is it possible to get the consistency of $\text{ZFC} + \forall k \in \omega (\text{cov}(\mathbf{SP}) < \text{cov}(\mathbf{SP}_k))$?*

We are interested in the relationship between $\text{non}(\mathbf{SP})$ and $\text{cov}(\mathbf{SP})$. It follows from the fact that the Cohen forcing is σ -centered that, in the Cohen model, $\text{non}(\mathbf{SP}) < \text{cov}(\mathbf{SP})$. However, we do not know if it is possible to construct a model where $\text{non}(\mathbf{SP}) > \text{cov}(\mathbf{SP})$.

Question 3. *Is $\text{non}(\mathbf{SP}) \leq \text{cov}(\mathbf{SP})$?*

A related question, as to whether $\text{non}(\mathbf{AS}_n) \leq \text{cov}(\mathbf{AS}_n)$ was asked in [NR93]. Finally, we would like to discuss about the relation of the cardinal numbers of the ideals \mathbf{SP}_k and \mathbf{AS}_{2^k} . In this work we showed that these ideals share a lot of properties, however we do not know if they share the same cardinal invariants. There is a connection between 2^k -anti-Sacks trees and k -porous sets given by the following argument: Let $\varphi_k : 2^k \rightarrow {}^k 2$ be a bijective function. Let $\psi_k : {}^\omega(2^k) \rightarrow {}^\omega 2$ defined by $\psi_k(x) = \varphi_k(x(0)) \frown \varphi_k(x(1)) \frown \dots$. Clearly, if $\psi_n(A) \in \mathbf{SP}_n$, then $A \in$

\mathbf{AS}_{2^n} . We do not know if this can be used to show a relation between the cardinal invariants of the ideals \mathbf{SP}_k and \mathbf{AS}_{2^k} .

Question 4. *Is $\text{non}(\mathbf{SP}_k) = \text{non}(\mathbf{AS}_{2^k})$? Is $\text{cov}(\mathbf{SP}_k) = \text{cov}(\mathbf{AS}_{2^k})$?*

Chapter 4

The Michael Space Problem

4.1 Introduction

One of the most common examples of topological spaces is the Sorgenfrey line. The *Sorgenfrey line* \mathbb{R}_l is the topological space whose set of points is \mathbb{R} and the topology is generated by the intervals of the form $(a, b]$. It is easy to show that \mathbb{R}_l is a Lindelöf space, but $\mathbb{R}_l \times \mathbb{R}_l$ is not Lindelöf. The conclusion is that the Lindelöf property is not preserved under products. However, there are some topological spaces which preserves the "*Lindelöfness*" in products.

Definition 4.1.1. A Lindelöf space X is productively Lindelöf if for every Lindelöf space Y , $X \times Y$ is Lindelöf.

There are some examples of this kind of spaces: the compact spaces and the σ -compact spaces (countable unions of compact spaces) are productively Lindelöf. It is natural to ask if all Lindelöf metrizable spaces are productively Lindelöf. It turns out this is not the case; we will show that there is a Lindelöf metrizable space which is not productively Lindelöf:

Let $B \subseteq \mathbb{R}$ be any Bernstein set and let X_B be the real line with the topology generated by the euclidean topology and the sets of the form $\{x\}$ with $x \in B$. We will prove that B is not a productively Lindelöf space, i.e. X_B is a Lindelöf space and that $B \times X_B$ is not a Lindelöf space:

(X_B is Lindelöf). Let \mathcal{U} be any open cover for X_B . Use the fact that $X_B \setminus B$ is Lindelöf to find a countable subcover $\mathcal{U}' \subseteq \mathcal{U}$ for $X_B \setminus B$. Observe that $X_B \setminus \bigcup \mathcal{U}'$ is an euclidian closed set, therefore only a countable

amount of points of B are outside of $\bigcup \mathcal{U}'$. From this, it follows easily that X_B is a Lindelöf space.

($X_B \times B$ is not Lindelöf). This follows from the fact that $\{\langle b, b \rangle : b \in B\}$ is an uncountable closed discrete subspace.

This example may seem pathological and one would like to construct a definable example, however, it turns out that finding an example of a metrizable productively Lindelöf spaces that are not σ -compact is hard: In [Tal11], Franklin D. Tall shows, under CH, that every productively Lindelöf space is σ -compact.

In particular, under CH, there is a Lindelöf space X such that $X \times \omega^\omega$ is not Lindelöf. This yields a natural question, first asked by E. Michael in [Mic63]:

Question 5. *Is there a Lindelöf space X such that $X \times \omega^\omega$ is not Lindelöf?*

Such kind of spaces are called *Michael Spaces* and, until today, it is still unknown if they exists in ZFC. Partial answers of this question can be found in [Mic71], [Als90], [AG95] and [Moo99].

We are interested in studying these kinds of spaces and its relationship between different combinatorial notions such as ideals and filters or cardinal invariants.

4.2 Michael Spaces and Cardinal Invariants

E. Michael was the first person to construct a Michael Space. In [Mic63] he defined a class of spaces and proved that, under CH, one of them was a Michael space. We are going to construct the class of spaces that E. Michael defined in his article. These spaces are similar to the example that we constructed at the beginning of the chapter:

Identify $2^\omega = \mathbb{Q} \cup \omega^\omega$ and let $A \subseteq \omega^\omega$. Define X_A be the topological space such that its set of points is $\mathbb{Q} \cup A$, topology is generated by the product topology on 2^ω and the sets of the form of $\{a\}$ with $a \in A$. By using a similar argument that the one we gave above, $X_A \times \omega^\omega$ is not a Lindelöf space whenever A is an uncountable set. It turns out that X_A may not be a Lindelöf space. For studying this, we will need the following definition.

Definition 4.2.1. *An uncountable set $A \subseteq \omega^\omega$ is concentrated on \mathbb{Q} if for every compact set $K \subseteq \omega^\omega$ (according to the product topology) the intersection $A \cap K$ is countable.*

Note that the notion of concentrated has a certain similarity with the notion of Luzin sets, but replacing the meager property with the compact property. We will see that this notion encloses exactly the cases where X_A is Lindelöf. The proof of the following proposition can also be found in [Dou84].

Proposition 4.2.1. *X_A is a Lindelöf space if and only if A is concentrated.*

Proof. (\Rightarrow). Let $K \subseteq \omega^\omega$ be a compact set. Define $\mathcal{U} = \{\omega^\omega \setminus K\} \cup \{\{a\} : a \in A\}$. Then \mathcal{U} is an open cover of X_A , so there is a countable subcover $\mathcal{U}' \subseteq \mathcal{U}$. The conclusion follows from the fact that $K \cap A = \{a \in A : \{a\} \in \mathcal{U}'\}$.

(\Leftarrow). Let \mathcal{U} be an open cover of basic sets of X_A . Pick a countable subset $\mathcal{U}' \subseteq \mathcal{U}$ such that $Q \subseteq \bigcup \mathcal{U}'$. Observe that $\omega^\omega \setminus \bigcup \mathcal{U}'$ is a compact set (with respect of the product topology) and therefore $A \setminus \bigcup \mathcal{U}'$ is countable. The conclusion follows easily from this last observation. \square

It is not surprising that concentrated sets cannot be found in ZFC alone. In [Dou84], van Douwen characterized the existence of concentrated sets in terms of cardinal invariants.

Proposition 4.2.2 ([Dou84]). *There exists a concentrated set if and only if $\mathfrak{b} = \omega_1$.*

Proof. (\Rightarrow). Let $A \subseteq \omega^\omega$ be a concentrated set, and let $A' \in [A]^{\omega_1}$, we will show that A' is an unbounded set: Let $f \in \omega^\omega$ and let $K = \{g \in \omega^\omega : g \leq^* f\}$. It follows that K is a σ -compact set, and therefore $K \cap A$ is countable, so there is a $g \in A' \setminus K$. In other words, there is a function $g \in A'$ not bounded by f .

(\Leftarrow). Let $A = \{f_\alpha : \alpha \in \omega_1\}$ be an unbounded family well-ordered by \leq^* . We will show that A is a concentrated set: Let $K \subseteq \omega^\omega$ be a compact set and let $f \in \omega^\omega$ be a function such that $g \leq f$ for every $g \in K$. It follows that only a countable amount of f_α can be smaller than f , so the conclusion follows immediately. \square

As a corollary, we get the Michael space that E. Michael constructed in [Mic63].

Theorem 4.2.1. *Under $\mathfrak{b} = \omega_1$ there is a Michael space.*

Proof. Let A be a concentrated set, then X_A is a Lindelöf space and $X_A \times \omega^\omega$ is not Lindelöf. \square

The Michael space problem has been thoroughly studied in the literature. In [Als90], K. Alster constructed a Michael space under MA. In [Moo99], J. Moore gave a combinatorial characterization of the existence of a Michael space, which we will present in this work. Before we continue, we will need to define the following topological cardinal invariant: If X is a non-Lindelöf space, then $L(X)$ will denote the smallest cardinality of an open cover without a countable subcover. The following notion was introduced in [Moo99].

Definition 4.2.2. *A sequence $\{X_\alpha : \alpha \leq \kappa\} \subseteq \mathcal{P}(\omega^\omega)$ is a κ -Michael sequence if the sequence is \subseteq -increasing, for every $\alpha < \kappa$, $X_\alpha \neq X_\kappa = \omega^\omega$, and for every K_σ set $K \subseteq \omega^\omega$, the ordinal $\delta_K = \min\{\alpha \leq \kappa : K \subseteq X_\alpha\}$ does not have uncountable cofinality.*

If, additionally, for every analytic set $A \subseteq \omega^\omega$, the ordinal $\delta_A = \min\{\alpha \leq \kappa : A \subseteq X_\alpha\}$ is either κ or does not have uncountable cofinality, then the sequence is said to be reduced.

Observe that there are no κ -Michael sequences with $\kappa < \mathfrak{b}$ such that κ has uncountable cofinality: If $\{X_\alpha : \alpha \leq \kappa\}$ is a sequence of subsets of ω^ω such that for all $\alpha < \kappa$, $X_\alpha \neq \omega^\omega$, then it is possible to pick an $f_\alpha \in \omega^\omega \setminus X_\alpha$. If $\kappa < \mathfrak{b}$, then it is possible to find a K_σ set K such that $f_\alpha \in K$ for each $\alpha < \kappa$. It is evident that, for each $\alpha < \kappa$, X_α does not contain K , and therefore $\delta_K = \kappa$.

J. Moore proved in [Moo99] that the existence of one of these sequence is almost equivalent to the existence of a Michael space. We present a weaker version of said theorem:

Theorem 4.2.2. *1. If there is a κ with uncountable cofinality such that there is a κ -Michael sequence, then there is a Michael space.*

2. If there is a Michael space X such that $L(X \times \omega^\omega) = \kappa$, then there is a κ -Michael sequence.

Proof. (1.) Let $\{X_\alpha : \alpha \leq \kappa\}$ be a κ -Michael sequence and let $M_\alpha = \bigcup_{\beta \leq \alpha} \{\beta\} \times (2^\omega \setminus X_\beta)$. We will show that M_α is a Lindelöf space by induction over α : It follows that M_0 is a separable metric space, and therefore it is Lindelöf. Assume that M_β is Lindelöf for every $\beta < \alpha$, we will show that M_α is Lindelöf. If α has countable cofinality, then it is easy to see that M_α is a Lindelöf space. Assume that α has uncountable cofinality and let \mathcal{U} be an open cover for M_α . We will think that \mathcal{U} consists of sets of the form $U \times I$, where U is an open set of 2^ω and I is an interval of $[0, \alpha + 1]$. Pick a countable $\mathcal{U}' \subseteq \mathcal{U}$ such that \mathcal{U}' covers $\{\alpha\} \times 2^\omega \setminus X_\alpha$ and let $K = \{x \in 2^\omega : \langle \alpha, x \rangle \notin \bigcup \mathcal{U}'\}$. Observe that K is a compact set of ω^ω and $K \subseteq X_\alpha$, so we will use the fact that α has uncountable cofinality and that $\{X_\alpha : \alpha \leq \kappa\}$ is a κ -Michael sequence to find a $\beta < \alpha$ such that $K \subseteq X_\beta$. Then, we observe that there must be a δ such that $\beta \leq \delta < \alpha$ and that \mathcal{U}' covers $(2^\omega \setminus K) \times (\delta, \alpha + 1]$. Now we can use the inductive hypothesis to find a countable $\mathcal{U}'' \subseteq \mathcal{U}$ such that \mathcal{U}'' covers M_δ . It follows that $\mathcal{U}' \cup \mathcal{U}''$ covers M_α . This argument finishes the induction and then, for each $\alpha \leq \kappa$, M_α is a Lindelöf space.

Finally, we must show that $M_\kappa \times \omega^\omega$ is not a Lindelöf space: First, observe that the set $D = \{\langle \alpha, x, x \rangle : \langle \alpha, x \rangle \in M_\kappa \text{ and } x \in \omega^\omega\}$ is closed in $M_\kappa \times \omega^\omega$. Then, observe that $\mathcal{U} = \{M_\alpha \times \omega^\omega : \alpha \in \kappa\}$ is an open cover for D without countable subcovers (without subcovers with cardinality smaller than $\text{cof}(\kappa)$).

(2.) Let X be a Michael space, let κ be such that $L(X \times \omega^\omega) = \kappa$ and let $\{U_\alpha : \alpha \in \kappa\}$ be an open cover of $X \times \omega^\omega$ without countable subcover. For each $\alpha \leq \kappa$, let $X_\alpha = \{x \in \omega^\omega : X \times \{x\} \subseteq \bigcup_{\beta < \alpha} U_\beta\}$. We will see that $\{X_\alpha : \alpha \leq \kappa\}$ is a κ -Michael sequence: It is immediate to see that the sequence is \subseteq -increasing and that, for every $\alpha < \kappa$, $X_\alpha \neq X_\kappa = \omega^\omega$. The only thing left to show is that, for every K_σ set $K \subseteq \omega^\omega$, δ_K does not have uncountable cofinality: Suppose that δ_K has uncountable cofinality, then it follows that $\mathcal{U}' = \{U_\alpha : \alpha \in \delta_K\}$ is an open cover for $X \times K$ without a countable subcover, however this is impossible because the product of a Lindelöf space with a σ -compact space is a Lindelöf space. \square

If we take a look at the proof of the part 1 of theorem above, we observe that there is little we can say about $L(M_\kappa \times \omega^\omega)$. The only thing

we can say about it is that $L(M_\kappa \times \omega^\omega) \leq \kappa$. If you start with a reduced κ -Michael sequence, then $L(M_\kappa \times \omega^\omega) = \kappa$. The original version of the last theorem is stronger, but we will only make use of the weaker version that we stated above. The original version is the following theorem.

Theorem 4.2.3 ([Moo99]). *Let κ be a cardinal with uncountable cofinality. Then there is a Michael space M with $L(M \times \omega^\omega) = \kappa$ if and only if there is a reduced κ -Michael sequence.*

There is something more about Michael sequences that we can say about in the case that $\mathfrak{d} < \aleph_\omega$. Observe that if M is a Michael space then $L(M \times \omega^\omega) \leq \mathfrak{d}$: This follows easily from the fact that ω^ω can be covered with \mathfrak{d} compact sets. So, according to the Theorem 2, if there is a κ -Michael sequence, then there is a Michael space with $L(M \times \omega^\omega) = \lambda$, $\lambda \leq \mathfrak{d}$ and λ with uncountable cofinality (it follows from $\lambda < \aleph_\omega$). Applying the same theorem again, we can find a λ -Michael sequence. Therefore, the existence of Michael sequences implies the existence of a λ -Michael sequence with $\mathfrak{b} \leq \lambda \leq \mathfrak{d}$. A similar argument can be done to prove that the existence of a reduced Michael sequence implies the existence of a reduced λ -Michael sequence with $\mathfrak{b} \leq \lambda \leq \mathfrak{d}$ (for this, you need to use the original version of Moore's theorem, also you can drop the requirement of $\mathfrak{d} < \aleph_\omega$). In [Moo99], also constructed, under $\mathbf{MA} + \mathfrak{c} = \aleph_{\omega+1}$, a Michael space M such that $L(M \times \omega^\omega) = \aleph_\omega$, so it is possible to have a Michael space M such that $L(M \times \omega^\omega)$ has countable cofinality (hence the importance of κ having uncountable cofinality in the argument that there are no κ -Michael sequences with $\kappa < \mathfrak{b}$).

As an application of the theorem 2, we can easily prove that $\mathfrak{b} = \omega_1$ implies the existence of a Michael space: Let $\{f_\alpha : \alpha \in \omega_1\}$ be an \leq^* -unbounded family and define, for each $\alpha \leq \omega_1$, $X_\alpha = \{f \in \omega^\omega : \forall \beta < \alpha (f \not\leq^* f_\beta)\}$. It is easy to see that $\{X_\alpha : \alpha \leq \omega_1\}$ is a reduced \mathfrak{b} -Michael sequence. For our next application, we will need the following lemma, whose proof can be found in [Sol94].

Lemma 4.2.1 ([Sol94]). *Let $A \subseteq \omega^\omega$ be an analytic set and let \mathcal{F} be a cover of A by closed sets. If \mathcal{F} has no countable subcover, then there is a nonempty G_δ subset $G \subseteq A$ homeomorphic to ω^ω such that, for every $F \in \mathcal{F}$, $F \cap G$ is nowhere dense in G .*

Theorem 4.2.4 ([Moo99]). *If $\mathfrak{d} = \text{cov}(\mathcal{M})$, then there is a Michael space.*

Proof. Let $\{f_\alpha : \alpha \in \mathfrak{d}\} \subseteq \omega^\omega$ be a \leq -dominating family and define $X_\alpha = \{f \in \omega^\omega : \exists \beta < \alpha (f \leq f_\beta)\}$. We will see that $\{X_\alpha : \alpha \leq \mathfrak{d}\}$ is a \mathfrak{d} -Michael sequence: The only non-trivial work we have to do is to show that, for every F_σ set $K \subseteq \omega^\omega$, δ_K has countable cofinality. For $\alpha \in \mathfrak{d}$, define $f_\alpha \downarrow = \{g \in \omega^\omega : g \leq f_\alpha\}$. Observe $\{f_\alpha \downarrow : \alpha \in \delta_K\}$ is a cover of K by closed sets. Using the lemma 4.2.1 we see that, if you can not find a countable subcover (ie if δ_K does not have countable cofinality), then you can find a set $D \subseteq K$ homeomorphic to ω^ω such that $f_\alpha \downarrow \cap D$ is nowhere dense in D . The latter is impossible because $\delta_K < \text{cov}(\mathcal{M})$, therefore δ_K has countable cofinality. \square

In the proof of the last theorem, the choice of the dominating family was not important; the proof will still work no matter which dominating family you pick. In general, this may not be the case, as seen in the following theorem that appears in [Moo99].

Theorem 4.2.5. *There is a compact set $K \subseteq \omega^\omega$ and a family of functions $\{f_\alpha : \alpha \in \text{cov}(\mathcal{M})\} \subseteq \omega^\omega$ such that, for each $\alpha \in \text{cov}(\mathcal{M})$, f_α only bounds a nowhere dense set in K and for each $f \in K$ there is $\alpha \in \text{cov}(\mathcal{M})$ such that $f \leq f_\alpha$*

Proof. Let $\{t_n : n \in \omega\}$ be an enumeration of $2^{<\omega}$ and let $\{C_\alpha : \alpha \in \text{cov}(\mathcal{M})\}$ be a family of closed nowhere dense sets such that $2^\omega = \bigcup \{C_\alpha : \alpha \in \text{cov}(\mathcal{M})\}$. Let \mathcal{K} be

$$\mathcal{K} = \{A \subseteq \omega : \text{there is a single } x \in 2^\omega \text{ such that}$$

$$\{t_n : n \in A\} = \{x \upharpoonright k : k \in \omega\}\}.$$

It can be easily shown that $\mathcal{K} \subseteq \mathcal{P}(\omega)$ is closed, and therefore \mathcal{K} is compact. For each $\alpha \in \text{cov}(\mathcal{M})$, define

$$B_\alpha = \{n \in \omega : t_n \text{ is an initial segment for an element of } C_\alpha\}.$$

Observe that, for each $\alpha \in \text{cov}(\mathcal{M})$, the set $\{A \in \mathcal{K} : A \subseteq B_\alpha\}$ is a closed nowhere dense set in \mathcal{K} . Now let $\Psi : \mathcal{P}(\omega) \rightarrow \omega^\omega$ such that $\Psi(A)(n) = |A \cap n|$. It can be easily shown that Ψ is an embedding and that $A \subseteq$

B implies $\Psi(A) \leq \Psi(B)$, so let $K = \Psi(\mathcal{K})$ and let $f_\alpha = \Psi(B_\alpha)$. The conclusion follows easily. \square

The last theorem blocks the possibility of copying the proof of the Theorem 4.2.4 in case that $\text{cov}(\mathbb{M}) < \mathfrak{d}$. If we are not careful, we might end up picking a dominant family, such that it has the family that we constructed in the theorem above as an initial segment, stopping our chances of getting a Michael sequence.

It is still unknown if you can find a dominating family such that it defines a \mathfrak{d} -Michael sequence. We do not know if the generic reals of the Laver or Mathias model can be used to construct a Michael sequence for example.

4.3 Michael Ultrafilters

Back in the proof of the theorem 4.2.4, J. Moore used a \leq^* -dominating family to construct a Michael sequence, so it is natural to try to change the order given by the finite sets to make some room for making mistakes. We will study the notion of the order given by ultraproducts in the terms of Michael sequences.

Definition 4.3.1. Given an ultrafilter \mathcal{U} over ω and two functions $f, g \in \omega^\omega$, we will say that $f \leq_{\mathcal{U}} g$ if $\{n \in \omega : f(n) \leq g(n)\} \in \mathcal{U}$.

Observe that $\leq_{\mathcal{U}}$ is a linear order that extends \leq^* . The *dominating number according to \mathcal{U}* , also called *cofinality of the ultrapower given by \mathcal{U}* , is the following cardinal invariant:

$$\mathfrak{d}_{\mathcal{U}} = \min\{|F| : F \subseteq \omega^\omega \text{ is } \leq_{\mathcal{U}} \text{-dominating}\}.$$

Given any ultrafilter \mathcal{U} , the inequality $\mathfrak{b} \leq \mathfrak{d}_{\mathcal{U}} \leq \mathfrak{d}$ can be easily verified. Note that $\mathfrak{d}_{\mathcal{U}}$ is always a regular cardinal. In [Can89], Canjar proved that there is always an ultrafilter \mathcal{U} such that $\mathfrak{d}_{\mathcal{U}} = \text{cof}(\mathfrak{d})$, therefore the inequality $\mathfrak{d}_{\mathcal{U}} \leq \mathfrak{d}$ is optimal, at least in the cases where \mathfrak{d} is regular. It turns out that \mathfrak{g} is related to the cofinalities of the ultrapowers. The following theorem was proved originally in [BM99]

Theorem 4.3.1. For every ultrafilter \mathcal{U} , $\mathfrak{d}_{\mathcal{U}} \geq \mathfrak{g}$.

Proof. Let $\{f_\alpha : \alpha \in \mathfrak{d}_\mathcal{U}\}$ be an increasing, $\leq_\mathcal{U}$ -dominating family of strictly increasing functions. For each infinite $X \subseteq \omega$, define $\text{Next}_X : \omega \rightarrow \omega$ as $\text{Next}_X(n) = \min X \setminus n$. Given $\alpha \in \mathfrak{d}_\mathcal{U}$, define $G_\alpha = \{X \subseteq \omega : \text{Next}_X \leq_\mathcal{U} f_\alpha\}$. We will show that $\mathcal{G} = \{G_\alpha : \alpha \in \mathfrak{d}_\mathcal{U}\}$ is a witness for \mathfrak{g} :

Obviously $\bigcap \mathcal{G} = \emptyset$, so we only need to show that \mathcal{G} is a family of groupwise dense sets: Clearly G_α is closed under infinite subsets and under finite modifications, so the only thing left to do is to show that, given a partition $\{I_k : k \in \omega\}$ of ω into finite sets, we can find $A \in [\omega]^\omega$ such that $\bigcup_{k \in A} I_k \in G_\alpha$. Recursively construct $P \subseteq \omega$ such that if $k \in P$, then for every $i \in k \cap P$ and for every $x \in I_i$, $f_\alpha(x) \leq \min I_k$. Let P_0, P_1 be a partition of P such that if $k \in P_0$, then $\min P \setminus (k+1) \in P_1$. For every $i \in 2$, define $A_i = \bigcup_{k \in P_i} I_k$. Observe that, if $n \notin I_0$ and $f_\alpha(n) > \text{next}_{A_0}(n)$, then $f_\alpha(n) \leq \text{next}_{A_1}(n)$, and as a consequence, either $A_0 \in G_{f_\alpha}$ or $A_1 \in G_{f_\alpha}$. \square

In [BM99], the authors proved that neither \mathfrak{s} or $\text{cov}(\mathcal{M})$ are lower bounds for $\mathfrak{d}_\mathcal{U}$, so \mathfrak{g} and \mathfrak{b} are the best lower bound we can get using only the usual cardinal invariants (the ones that are in Van Dowen and in the Cichoń diagrams).

In this work we will try to construct Michael sequences using ultrafilters, we will consider two different approaches.

Definition 4.3.2. *An ultrafilter \mathcal{U} is a Michael Ultrafilter if there is an increasing $\leq_\mathcal{U}$ -dominating sequence $\{f_\alpha : \alpha \in \mathfrak{d}_\mathcal{U}\}$ with the following property \star : For every F_σ set $K \subseteq \omega^\omega$, the ordinal $\delta_K = \min\{\alpha \leq \kappa : \forall f \in K(\exists \beta < \alpha(f \leq_\mathcal{U} f_\beta))\}$ does not have uncountable cofinality. An ultrafilter \mathcal{U} is a strongly Michael Ultrafilter if every increasing $\leq_\mathcal{U}$ -dominating sequence $\{f_\alpha : \alpha \in \mathfrak{d}_\mathcal{U}\}$ has the property \star .*

Of course, if an ultrafilter is strongly Michael, then it is Michael, and if there is a Michael ultrafilter \mathcal{U} , then you can easily construct a $\mathfrak{d}_\mathcal{U}$ -Michael sequence and therefore a Michael space. There is an easy way to classify strongly Michael ultrafilters. First, we will need the following cardinal invariants:

Let \mathcal{U} be an ultrafilter and let $A \in [\omega]^\omega$, then the *internal \mathcal{U} -dominating number according to A* is the following cardinal invariant:

$$\mathfrak{d}_{\mathcal{U}}(A) = \min\{|F| : F \subseteq A \wedge (\forall a \in A (\exists f \in F (a \leq_{\mathcal{U}} f)))\}$$

In other words, it is the smallest size of a $\leq_{\mathcal{U}} \upharpoonright_A$ -dominating family. Observe that this is always a regular cardinal. We define *the internal dominating number according to A* as the following cardinal

$$\mathfrak{d}(A) = \min\{|F| : F \subseteq A \wedge (\forall a \in A (\exists f \in F (f \geq^* a)))\}.$$

Note that $\mathfrak{d}_{\mathcal{U}}(\omega^\omega) = \mathfrak{d}_{\mathcal{U}}$, $\mathfrak{d}(\omega^\omega) = \mathfrak{d}$ and $\mathfrak{d}(A) \geq \mathfrak{d}_{\mathcal{U}}(A)$ for every $A \in \omega^\omega$.

Even with relative "simple" sets, the internal dominating number can be large:

For each $A \subseteq \omega$ such that $\{a_n : n \in N\}$ is its increasing enumeration (if A is infinite, $N = \omega$, if not, N is a natural number) let $\varphi_A : \omega \rightarrow \omega$ be defined as follows:

$$\varphi_A(k) = \begin{cases} a_0 & \text{if } k = a_0 \\ a_{n+1} - a_n & \text{if } k = a_{n+1} \\ 0 & \text{if } k \notin A. \end{cases}$$

Observe that $\varphi : \mathcal{P}(\omega) \rightarrow \omega^\omega$ is a topological embedding. The following properties are easy to verify.

Proposition 4.3.1. *Let φ be the function defined above, then:*

1. *if $B \subseteq^* A$, then $\varphi_B \upharpoonright B \geq^* \varphi_A \upharpoonright B$,*
2. *if \mathcal{A} is an uncountable family of subsets of ω , and $\varphi(\mathcal{A}) = \{\varphi_A : A \in \mathcal{A}\}$, then $\mathfrak{d}(\varphi(\mathcal{A})) = |\mathcal{A}|$.*

Proof. (1) Let $n \in A$ be such that $B \setminus n \subseteq A$. Let $m \in B \setminus n$, and let $m_B \in B$ be the previous element of m in B and let m_A be the previous element of m in A . Clearly $m_A \geq m_B$ and therefore $\varphi_B(m) = m - m_B \geq m - m_A = \varphi_A(m)$.

(2) Let $\mathcal{F} \subset \mathcal{A}$ be such that $|\mathcal{F}| < |\mathcal{A}|$, we are going to show that $\{\varphi_B : B \in \mathcal{F}\}$ is not an internal dominating family. Let $A \in \mathcal{A}$ be such that, for every $B \in \mathcal{F}$, $B \not\subseteq^* A$. Now, we will show that for every $n \in \omega$ there is $m > n$ such that $\varphi_A(m) > \varphi_B(m)$: Given $n \in \omega$, find $m > n$ such

that $m \in A \setminus B$ or $m \in B \setminus A$. If $m \in A \setminus B$, then $\varphi_A(m) > 0 = \varphi_B(m)$. If $m \in B \setminus A$, then let $m' = \min(A \setminus m)$. It follows from the definition of φ_A and φ_B that $\varphi_A(m') > \varphi_B(m')$. \square

The proposition above gives us a wide range of examples with large internal dominating number. For example, if $\mathcal{A} \subseteq \mathcal{P}(\omega)$ is definable and uncountable, let $\varphi(\mathcal{A}) = \{\varphi_B : B \in \mathcal{A}\}$. It is clear that $\varphi(\mathcal{A})$ share the same topological properties than A (for example, if A is compact then $\varphi(\mathcal{A})$ is compact), then $\mathfrak{d}(\varphi(\mathcal{A})) = \mathfrak{c}$.

We will now prove a characterization of the notion of being strongly Michael ultrafilter.

Theorem 4.3.2. *An ultrafilter \mathcal{U} is strongly Michael if and only if for every σ -compact set $K \subseteq \omega^\omega$, if $\mathfrak{d}_{\mathcal{U}}(K) > \omega$, then $\mathfrak{d}_{\mathcal{U}}(K) \geq \mathfrak{d}_{\mathcal{U}}$.*

Proof. (\Rightarrow). Let $K \subseteq \omega^\omega$ be a σ -compact set such that $\mathfrak{d}_{\mathcal{U}}(K) > \omega$ and suppose that $\mathfrak{d}_{\mathcal{U}}(K) < \mathfrak{d}_{\mathcal{U}}$. Let $\{f_\alpha : \alpha \in \mathfrak{d}_{\mathcal{U}}(K)\}$ be an internal $\leq_{\mathcal{U}}$ -dominating family inside of K and extend it to a $\leq_{\mathcal{U}}$ -dominating $\{f_\alpha : \alpha \in \mathfrak{d}_{\mathcal{U}}\}$. It follows that $\delta_K = \mathfrak{d}_{\mathcal{U}}(K)$, which does not have countable cofinality. As a consequence \mathcal{U} is not a strongly Michael ultrafilter.

(\Leftarrow). Let $\{f_\alpha : \alpha \in \mathfrak{d}_{\mathcal{U}}\}$ be a $\leq_{\mathcal{U}}$ -dominating family and let $K \subseteq \omega^\omega$ be a σ -compact set. Let $\{g_\alpha : \alpha \in \mathfrak{d}_{\mathcal{U}}(K)\}$ be an internal $\leq_{\mathcal{U}}$ -dominating family inside of K . For each $\alpha \in \mathfrak{d}_{\mathcal{U}}(K)$ pick $\beta(\alpha) = \min\{\beta : g_\alpha \leq_{\mathcal{U}} f_\beta\}$. We have two cases:

Case 1 $\mathfrak{d}_{\mathcal{U}}(K) \leq \omega$. The family $\{\beta(\alpha) : \alpha \in \mathfrak{d}_{\mathcal{U}}\}$ is cofinal in δ_K , therefore δ_K has countable cofinality.

Case 2 $\mathfrak{d}_{\mathcal{U}}(K) \geq \mathfrak{d}_{\mathcal{U}}$. Observe that there is an $\gamma < \mathfrak{d}_{\mathcal{U}}(K)$ such that, for every γ' such that $\gamma < \gamma' < \mathfrak{d}_{\mathcal{U}}(K)$, $\beta(\gamma') = \beta(\gamma)$. Using this, it is easy to see that $\delta_K = \beta(\gamma) + 1$. \square

Now we will focus in some cases where strongly Michael ultrafilters exist. The following result is easy to show.

Proposition 4.3.2. *Suppose that \mathcal{U} is an ultrafilter such that $\mathfrak{d}_{\mathcal{U}} = \omega_1$, then \mathcal{U} is a strongly Michael ultrafilter. In particular, if $\mathfrak{d} = \omega_1$, then every ultrafilter is a strongly Michael ultrafilter.*

Proof. If K is a σ -compact set such that $\mathfrak{d}_{\mathcal{U}}(K) > \omega$, then $\mathfrak{d}_{\mathcal{U}}(K) \geq \mathfrak{d}_{\mathcal{U}} = \omega_1$. If $\mathfrak{d} = \omega_1$, then, for every \mathcal{U} ultrafilter, we have that $\mathfrak{d}_{\mathcal{U}} = \omega_1$. \square

This proposition shows that there are some models where every ultrafilter is a strongly Michael ultrafilter. Later in this chapter, we will show examples of models where there are no strongly Michael ultrafilters. We will need the following notion.

Definition 4.3.3. *An ultrafilter \mathcal{U} is everywhere Michael if for all σ -compact sets $K \subseteq \omega^\omega$, either $\mathfrak{d}_{\mathcal{U}}(K) \leq \omega$ or $\mathfrak{d}_{\mathcal{U}}(K) = \mathfrak{c}$.*

Everywhere Michael ultrafilters are the ultrafilters in which the compact sets behaves as nice as possible. Naturally, everywhere Michael implies strongly Michael, however, these notions are not necessarily equivalent. It is easy to see that, in the Sacks model, every ultrafilter is strongly Michael (a consequence of $\mathfrak{d} = \omega_1$). Also, it can be easily seen that, no matter which ultrafilter \mathcal{U} you pick, $\mathfrak{d}_{\mathcal{U}}(\varphi(\mathcal{P}(\omega))) = \chi(\mathcal{U})$. To finish the argument, we recall the fact that Sacks forcing preserves p -points, and, as a consequence, in the Sacks model there are ultrafilters such that $\mathfrak{d}_{\mathcal{U}}(\varphi(\mathcal{P}(\omega))) = \aleph_1$.

The internal dominating number will be specially helpful in the study of everywhere Michael ultrafilters. We will need the following well-known proposition.

Proposition 4.3.3. *Let \mathcal{I} be an F_σ -ideal such that $\text{cof}(\mathcal{I}) > \omega$, then $\text{cof}(\mathcal{I}) > \text{cov}(\mathcal{M})$.*

Proof. Let $\mathcal{D} \subseteq \mathcal{I}$ be a cofinal family. For each $A \in \mathcal{D}$, it can be easily shown that the family $A \downarrow = \{B \in \mathcal{I} : B \subseteq^* A\}$ is the countable union of closed sets. Then, lemma 4.2.1 implies that $|\mathcal{D}| \geq \text{cov}(\mathcal{M})$. \square

The following cardinal invariant will help us in the study of Michael ultrafilters.

$$\mu = \min\{\text{cof}(\mathcal{I}) : \mathcal{I} \text{ is an } F_\sigma \text{ ideal and } \text{cof}(\mathcal{I}) > \omega\}$$

In [HRRZ14], the authors construct a model where $\max\{\text{cof}(\mathcal{M}), \mathfrak{u}\} < \mu$. In the same article, the authors show that, in the Laver model, $\mu = \omega_1$, therefore $\text{cov}(\mathcal{M})$ is the best lower bound we have (among all the cardinals in Cichoń and Van Dowen's diagrams). An upper bound for μ is $\text{cof}(\mathcal{N})$, which is the cofinality of the summable ideal (a proof of this can

be found in [HHH07]). We will see how this cardinal invariant is related to everywhere Michael ultrafilters.

We will relate this cardinal to the internal dominating. We will need the following notion

Lemma 4.3.1. $\mu = \min\{\mathfrak{d}(K) : K \text{ is a } \sigma\text{-compact subset of } \omega^\omega \text{ and } \mathfrak{d}(K) > \omega\}$.

Proof. Let $\mu' = \min\{\mathfrak{d}(K) : K \text{ is a } \sigma\text{-compact subset of } \omega^\omega \text{ and } \mathfrak{d}(K) > \omega\}$. If \mathcal{I} is a F_σ ideal, then $K_{\mathcal{I}} = \{\chi_I : I \in \mathcal{I}\}$ is a σ -compact set such that $\mathfrak{d}(K) = \text{cof}(\mathcal{I})$. Using that $\text{cof}(\mathcal{I})$ is a regular cardinal, it is not hard to find a compact set $K' \subseteq K$ such that $\mathfrak{d}(K) = \mathfrak{d}(K')$. This shows that $\mu \leq \mu'$.

Given a compact set K such that $\mathfrak{d}(K) > \omega$ we can find an internally unbounded compact set $K' \subseteq K$ such that $\mathfrak{d}(K) = \mathfrak{d}(K')$. It turns out that $I_{K'}$ is an F_σ ideal and we already showed in a paragraph above that $\omega < \text{cof}(I_K) \leq \mathfrak{d}(K)$. This shows that $\mu' \leq \mu$. \square

It is not hard to show that $\mu \geq \text{cov}(\mathcal{M})$: If $K \subseteq \omega^\omega$ is a σ -compact set such that $\mathfrak{d}(K) > \omega$, then it is possible to find an internally unbounded compact set K' such that $\mathfrak{d}(K) = \mathfrak{d}(K')$. Observe that every $f \in K'$ only bounds a meager set inside K' , so no family with cardinality smaller than $\text{cov}(\mathcal{M})$ can be an internal \leq^* -dominating family inside K' . It is easy to show that $\mu \leq \text{cof}(\mathcal{N})$ (the summable ideal is an F_σ ideal). This cardinal is known to be *small* in any model with the Laver property (see [HRRZ14]), for example, $\mu = \omega_1$ in both Laver and Mathias model, so not even \mathfrak{b} is a lower bound. It is also known (see [HRRZ14]) that neither \mathfrak{u} or $\text{cof}(\mathcal{M})$ are lower bounds for μ . The reader can find more information about the cardinal μ [Hru11] and [HRRZ14]. We will use the following functions through the rest of the work:

Definition 4.3.4. Given an infinite set $A \subseteq \omega$ we will say that an infinite compact set $K \subseteq \omega^\omega$ is internally unbounded in A if for every $f \in K$ and for every $s \in \omega^\omega$ such that $\langle s \rangle \cap K \neq \emptyset$, there is a $g \in \langle s \rangle \cap K$ such that $g \upharpoonright A \not\leq^* f \upharpoonright A$. Given a family \mathcal{F} of subsets of ω and a compact $K \subseteq \omega^\omega$, we will say that K is internally unbounded in \mathcal{F} if K is internally unbounded in F for every $F \in \mathcal{F}$.

Observe that, if A is an infinite set and if K is internally unbounded in A then, for each $g \in K$ the set $\{f \in K : f \upharpoonright_A \leq^* g \upharpoonright_A\}$ is a meager set.

Lemma 4.3.2. *Let \mathcal{U} be an ultrafilter and let $K \subseteq \omega^\omega$ be a compact set such that $\mathfrak{d}_{\mathcal{U}}(K) > \omega$. Then, there is a compact set K' such that K' is internally unbounded in \mathcal{U} and $\mathfrak{d}_{\mathcal{U}}(K) = \mathfrak{d}_{\mathcal{U}}(K')$.*

Proof. Let

$$\Omega = \{s \in \omega^{<\omega} : \langle s \rangle \cap K \neq \emptyset \wedge \exists f_s \in K (\forall g \in \langle s \rangle \cap K (g \leq_{\mathcal{U}} f_s))\}.$$

Define $K' = \bigcap_{s \in \Omega} K \setminus \langle s \rangle$. It is easy to see that K' is an internally unbounded compact set in \mathcal{U} . To see that $\mathfrak{d}_{\mathcal{U}}(K) = \mathfrak{d}_{\mathcal{U}}(K')$, note that for each $f \in K$, either $f \in K'$ or there is an $s \in \Omega$ such that $f \in \langle s \rangle$. The collection of $f \in K$ with the later condition can be dominated by a countable collection of functions (namely the f_s), therefore $\mathfrak{d}_{\mathcal{U}}(K) = \mathfrak{d}_{\mathcal{U}}(K')$. \square

Cohen reals over internally dominating compact sets are especially well-behaved. They have a property that Cohen reals over regular compact sets lack: Cohen reals over internally dominating compact sets are unbounded: they cannot be bounded by functions inside K . Also, this property is hereditary: If K is an internally dominating compact set and A is an infinite set of natural numbers, then $K \upharpoonright A$ is an internally dominating compact set, so not only Cohen reals over a internally dominating compact set are unbounded, but they are unbounded in any restriction of K . We are ready to prove the following theorem.

Theorem 4.3.3. *Suppose that \mathfrak{c} is a regular cardinal.*

1. *If $\text{cov}(\mathcal{M}) = \mathfrak{c}$, then every filter \mathcal{F} such that $\chi(\mathcal{F}) < \mathfrak{c}$ can be extended to an everywhere Michael ultrafilter.*
2. *If $\mu < \mathfrak{c}$, then there is a filter \mathcal{F} that cannot be extended to an everywhere Michael ultrafilter.*

Proof. (1). Let \mathcal{F} be a filter basis such that $|\mathcal{F}| < \mathfrak{c}$. Let $\{A_\alpha : \alpha \in \mathfrak{c}\} = [\omega]^\omega$. $\{f_\alpha : \alpha \in \mathfrak{c}\} = \omega^\omega$ and let $\{K_\alpha : \alpha \in \mathfrak{c}\}$ be an enumeration of all internally unbounded compact sets, where each one is listed cofinally.

Now we construct $\{M_\alpha : \alpha \in \mathfrak{c}\}$ a list of subelementary models of $H(\kappa)$ such that, for each $\alpha \in \mathfrak{c}$, $|M_\alpha| < \mathfrak{c}$ and $(\bigcup_{\beta < \alpha} M_\beta) \cup \{A_\alpha, K_\alpha, f_\alpha, c_\alpha\} \subseteq M_\alpha$ where $\{c_\alpha : \alpha \in \mathfrak{c}\}$ is a collection of functions such that $c_{\alpha+1} \in K_\alpha$ is Cohen over M_α . Recursively we will construct, for each $\alpha \in \mathfrak{c}$, a filter basis F_α such that if K_α is internally unbounded in $\bigcup_{\beta < \alpha} F_\beta$:

1. $F = F_0$ and $F_\beta \subseteq F_\alpha$ whenever $\beta < \alpha$,
2. for each $\alpha > 0$, $F_\alpha \subseteq M_{\alpha+1}$,
3. for each $\alpha > 0$, either $A_\alpha \in F_\alpha$ or $\omega \setminus A_\alpha \in F_\alpha$,
4. for each $\alpha > 0$ and every $f \in K_\alpha \cap M_\alpha$, the set $\{n \in \omega : f(n) \leq c_{\alpha+1}(n)\} \in F_\alpha$.

Suppose we have already constructed F_β for $\beta < \alpha$. Now, K_α is an internally unbounded compact set and $c_{\alpha+1}$ is Cohen, so therefore the set $B(A, f) := \{n \in A : f_\alpha(n) \leq c_{\alpha+1}(n)\}$ is infinite for every $A \in M_\alpha$. In particular, for every $F \in \bigcup_{\beta < \alpha} F_\beta$ and for every $f \in K_\alpha \cap M_\alpha$ the set $B(F, f)$ is an infinite subset of F , and therefore $B(F, f) \in (\bigcup_{\beta < \alpha} F_\beta)^+$. So, in order to prove that $\bigcup_{\beta < \alpha} F_\beta \cup \{B(F, f) : f \in K_\alpha \cap M_\alpha, F \in \bigcup_{\beta < \alpha} F_\beta\}$ is a filter basis, we only need to show that, if $f_1, f_2, \dots, f_n \in K_\alpha \cap M_\alpha$, then $\bigcap_{i \leq n} B(F, f_i)$ is infinite: For every $i \leq n$, define $D_i = \{k \in F : f_i(k) \geq \max\{f_j(k) : j \leq n\}\}$. Observe that $\bigcup_{i \leq n} D_i = F$, so pick any $i \leq n$ such that D_i is infinite. Finally, note that $B(f_i, D_i) \subseteq \bigcap_{i \leq n} B(F, f_i)$ and therefore $F'_\alpha = \bigcup_{\beta < \alpha} F_\beta \cup \{B(F, f) : f \in K_\alpha \cap M_\alpha, F \in \bigcup_{\beta < \alpha} F_\beta\}$ is a filter basis. Clearly, F'_α satisfies 1, 2 and 4, so the only thing left to do is to add either A_α or its complement, so add whichever is positive (we will do this even if K_α is not internally unbounded in $\bigcup_{\beta < \alpha} F_\beta$ and observe that this can be done inside $M_{\alpha+1}$. This finishes the construction

Let $\mathcal{U} = \bigcup_{\alpha < \mathfrak{c}} F_\alpha$. Clearly \mathcal{U} is an ultrafilter extending \mathcal{F} . We will show that \mathcal{U} is an everywhere Michael ultrafilter: Let K be a σ -compact set such that $\mathfrak{d}_\mathcal{U}(K) > \omega$, we will show that $\mathfrak{d}_\mathcal{U}(K) = \mathfrak{c}$. First, using the lemma 4.3.2 we can easily find a compact set K_c such that $\mathfrak{d}_\mathcal{U}(K) = \mathfrak{d}_\mathcal{U}(K_c)$.

First, note that we can find an internally unbounded in \mathcal{U} compact set $K' \subseteq K$ such that $\mathfrak{d}_\mathcal{U}(K) = \mathfrak{d}_\mathcal{U}(K')$. Let $D \in [K']^{< \mathfrak{c}}$, let $\beta < \mathfrak{c}$ be such that

for each $D \subseteq M_\beta$ and $K_\beta = K_c$. Then it follows that $c_{\beta+1} \leq_{\mathcal{U}}$ -dominates each $f \in D$. This implies that $\mathfrak{d}_{\mathcal{U}}(K) = \mathfrak{c}$.

(\Rightarrow). Suppose that $\mu < \mathfrak{c}$ and let \mathcal{F} be an F_σ filter such that $\chi(\mathcal{F}) < \mathfrak{c}$ and let \mathcal{U} be any ultrafilter extending \mathcal{F} . Then $\mathfrak{d}_{\mathcal{U}}(K_{\mathcal{F}}) < \mathfrak{c}$. \square

This last theorem has a similar flavor to a theorem proved independently by Bartoszyński and Judah [BJ95] and Canjar [MC90].

Theorem 4.3.4. *Every filter \mathcal{F} such that $\chi(\mathcal{F}) < \mathfrak{c}$ can be extended to a selective ultrafilter if and only if $\text{cov}(\mathcal{M}) = \mathfrak{c}$.*

It is natural to ask the relationship between everywhere Michael ultrafilters (or even strongly Michael ultrafilters) and selective ultrafilters. We already proved that $\mu \geq \text{cov}(\mathcal{M})$, so the generic existence of selective ultrafilters implies the generic existence of Michael ultrafilters. We will study the relationship between these two notions in the following section.

4.4 Selectivity and Michael spaces.

The most natural candidate for a selective ultrafilter is a generic filter for $\mathcal{P}(\omega)/\text{Fin}$. Recall that $\mathcal{P}(\omega)/\text{Fin}$ is a σ -closed forcing which preserves cardinals below \mathfrak{h} , if $\kappa < \mathfrak{h}$, then this forcing does not add any new function from $\kappa \rightarrow \text{ON}$ and collapses \mathfrak{c} to \mathfrak{h} (see [BJ95] for a proof of these facts).

We already know that $\text{cov}(\mathcal{M}) = \mathfrak{c}$ implies the existence of both strongly Michael ultrafilters and selective ultrafilters, so it is natural to ask whether the existence of a selective ultrafilter implies the existence of a strongly Michael ultrafilter. We will start this section with the following theorem

Theorem 4.4.1. *Suppose that $\mathfrak{p} = \mathfrak{h}$, then*

$$\mathcal{P}(\omega)/\text{Fin} \Vdash \text{“}\dot{\mathcal{U}}_{gen} \text{ is a strongly Michael ultrafilter”}.$$

Proof. Note that $\mathcal{P}(\omega)/\text{Fin} \Vdash \mathfrak{d}_{\dot{\mathcal{U}}_{gen}} = \mathfrak{c}$ so we can use the fact that $\mathcal{P}(\omega)/\text{Fin}$ do not add new reals to see that the only thing we have to do is to prove that if K is a compact set such that $\mathcal{P}(\omega)/\text{Fin} \Vdash \mathfrak{d}_{\dot{\mathcal{U}}_{gen}}(K) > \omega$, then there is an infinite A such that $A \Vdash \mathfrak{d}_{\dot{\mathcal{U}}_{gen}}(K) = \mathfrak{c}$. Let K be a

compact set, let $\kappa < \mathfrak{h}$, let A be an infinite set and let $\{\dot{f}_\alpha : \alpha < \kappa\}$ be a sequence of $\mathcal{P}(\omega)/\text{Fin}$ names such that

$$A \Vdash “\{\dot{f}_\alpha : \alpha < \kappa\} \subseteq K \text{ is } \leq_{\dot{U}_{gen}} \text{ increasing}”.$$

It is routine to check that there is $B \subseteq A$ and a sequence $\{f_\alpha : \alpha < \kappa\} \subseteq K$ such that

- for every $\alpha < \beta < \kappa$, $f_\alpha \leq_B^* f_\beta$,
- for every $\alpha < \kappa$, $B \Vdash “\dot{f}_\alpha = f_\alpha”$.

It is easy to show that $\mathfrak{d}(K \upharpoonright B) > \omega$. Now, as $\kappa < \mathfrak{p} \leq \mu$, then there is an $f \in K$ such that, for every $\alpha < \kappa$, the set $P_\alpha = \{n \in B : f(n) \geq f_\alpha(n)\}$ is infinite. Note that the family $\{P_\alpha : \alpha < \kappa\}$ is decreasing so we can find a pseudo-intersection P . It follows easily that, for every $\alpha < \kappa$

$$P \Vdash “f_\alpha \leq_{\dot{U}_{gen}} f”.$$

□

The case where $\mathfrak{p} < \mathfrak{h}$ is more difficult. We will show a compact set that might be complicated to deal with. The following definition appears in [HRRZ14].

Definition 4.4.1. *An ideal \mathcal{I} on ω is gradually fragmented if there is a partition $\{a_i : i \in \omega\}$ into finite sets on ω and a collection of submeasures $\{\varphi_i : i \in \omega\}$ such that:*

- for each $i \in \omega$, φ_i is a submeasure on a_i ,
- for every $i \in \omega$, there is an $j, k \in \omega$ such that for all $l \in \omega$ and every $m > k$ and for every $B \subseteq \mathcal{P}(a_n)$, if B is such that $|B| = l$ and $\varphi_m(b) < i$ for every $b \in B$, then $\varphi_m(\bigcup B) < j$,
- $\mathcal{I} = \{b \subseteq \omega : \exists k(\forall j(\varphi_j(a_j \cap b) < k))\}$.

It is not difficult to see that these ideals are F_σ ideals. Observe that if \mathcal{I} is a gradually fragmented ideal and $A \in [\omega]^\omega$, then $\mathcal{I} \upharpoonright A$ is gradually

fragmented. A typical example of this kind of ideals is the *polynomial growth ideal* (first appeared in [Maz00])

$$\mathcal{I} = \{A \subseteq \omega : \exists k \in \omega (\forall n \in \omega (|(A \cap 2^n)| \leq n^k))\}.$$

In [HRRZ14], the authors proved that these ideals have small cofinality in both the Mathias and in the Laver model. Before doing that, we need to introduce the notion of Laver property:

Definition 4.4.2. *A forcing \mathbb{P} has the Laver property if for every \mathbb{P} -name for a function f such that there is $g \in \omega^\omega$ such that $\mathbb{P} \Vdash "f \leq^* g"$, then there is a sequence of sets $\{L_i : i \in \omega\}$.*

Proposition 4.4.1. *Let \mathbb{P} be a proper forcing notion such that \mathbb{P} has the Laver property and let \mathcal{I} be a gradually fragmented ideal. Then*

$$\mathbb{P} \Vdash "\mathcal{I} \cap V \text{ is cofinal in } \mathcal{I}."$$

Proof. Let $\{a_k : k \in \omega\}$ be a partition into finites sets of ω and let $\{\varphi_i : i \in \omega\}$ be a collection of submeasures such that they witness that \mathcal{I} is a gradually fragmented ideal. Let \dot{I} be a \mathbb{P} -name and let $p \in \mathbb{P}$ such that $p \Vdash "\dot{I} \in \mathcal{I}"$. Let $k \in \omega$ and $p' \leq p$ be such that $p' \Vdash "\forall i \in \omega (\varphi_i(I \cap a_i) < k)"$. \square

As a consequence, there are models where all the gradually fragmented ideals have cofinality ω_1 , but $\mathfrak{h} > \omega_1$ (for example, the Mathias model). The following cardinals will be crucial for the study of this problem.

Given a set $K \subseteq \omega^\omega$, define

$$\mathfrak{b}^*(K) = \min\{|F| : F \subseteq K (\forall A \in [\omega]^\omega (\forall g \in K (\exists f \in F (f \upharpoonright A \not\leq^* g \upharpoonright A))))\}.$$

It is easy to show that $\mathfrak{b}^*(K) \leq \mathfrak{d}(K)$, and they are equal whenever $\mathfrak{b}^*(K)$ is small.

Proposition 4.4.2. *If $\mathfrak{b}^*(K) < \mathfrak{p}$, then $\mathfrak{d}(K) = \mathfrak{b}^*(K)$.*

Proof. Let $F \subseteq K$ be a witness for $\mathfrak{b}^*(K) \leq \mathfrak{p}$. We will see that F is an internal \leq^* -dominating family: Suppose this is not the case and let $g \in K$ be such that for every $f \in F$, $g \not\leq^* f$. For each $f \in F$, define $A_f = \{n \in \omega : g(n) > f(n)\}$ and let $\mathcal{A} \subseteq \{A_f : f \in F\}$ be a maximal centered family. Let A be a pseudointersection of \mathcal{A} . It is easy to show that, for each $f \in F$, $g \upharpoonright A \geq^* f \upharpoonright A$. This contradicts that $F \subseteq K$ is a witness for $\mathfrak{b}^*(K)$. \square

We conjecture that the gradually fragmented ideals can be used to construct (in the Mathias model) an example of a compact set such that, after forcing with $\mathcal{P}(\omega)/\text{Fin}$, the compact set will have a small dominating number according to the generic ultrafilter.

4.5 Michael ultrafilters may not exist

We already showed that it is consistent that every ultrafilter is a strongly Michael Ultrafilter (for example, under CH), we already showed that it is consistent that some ultrafilters are not strongly Michael (in the Mathias or in the Laver model). We will show that it is consistent that no ultrafilter is strongly Michael. We will use the following notion.

Definition 4.5.1. *Let \mathcal{F} and \mathcal{G} be two filters on ω . We will say that \mathcal{F} and \mathcal{G} are nearly coherent if there is a finite to one function $f : \omega \rightarrow \omega$ such that $f(\mathcal{F}) \cup f(\mathcal{G})$ generates a filter.*

It turns out that finite to one functions preserves some properties of filters: if $f : \omega \rightarrow \omega$ is a finite to one function and \mathcal{U} is an ultrafilter, then $f(\mathcal{U})$ generates an ultrafilter such that $\chi(\mathcal{U}) = \chi(f(\mathcal{U}))$. If \mathcal{U} is a p-point, then $f(\mathcal{U})$ generates a p-point.

In [Bla86], A. Blass introduces the *near coherence of filters* principle and he uses this principle to classify models of arithmetic. This principle states that every two ultrafilters are nearly coherent. In [BL89], A. Blass and C. Laflamme proved the following theorem:

Theorem 4.5.1. *The near coherence of filters follows from $\mathfrak{u} < \mathfrak{g}$.*

Proof. Let \mathcal{U} be an ultrafilter such that $\chi(\mathcal{U}) < \mathfrak{g}$, let $\mathcal{B} \subseteq \mathcal{U}$ a filter basis with cardinality $\chi(\mathcal{U})$ and let \mathcal{V} be any other ultrafilter. We will find a

finite to one function $f : \omega \rightarrow \omega$ such that $f(\mathcal{U}) = f(\mathcal{V})$. For each $F \in \mathcal{B}$ define:

$$G_B = \{X \in [\omega]^\omega : \exists U \in \mathcal{V}(\exists n, m \in X([n, m] \cap F = \emptyset \Rightarrow [n, m] \cap U = \emptyset))\}$$

Clearly each G_B is a groupwise dense set, therefore we can find an $X \in \bigcap_{B \in \mathcal{B}} G_B$. Define $f : \omega \rightarrow \omega$ as $f(n) = |X \cap [0, n]|$. It is immediate to see that f is a finite to one function. We will show that $f(\mathcal{U}) = f(\mathcal{V})$: Let $B \in \mathcal{B}$ and let $V \in \mathcal{V}$ be such that it witnesses that $X \in G_B$. Observe that $f(V) \subseteq f(B)$. This implies that the filter generated by $f(\mathcal{V})$ contains the filter generated by $f(\mathcal{U})$. The equality follows from the fact that $f(\mathcal{U})$ generates an ultrafilter. \square

We will need the following proposition. This was originally proved by Ketonen and can be found in [BJ95].

Proposition 4.5.1. *Suppose that \mathcal{U} is an ultrafilter such that $\chi(\mathcal{U}) < \mathfrak{d}$, then \mathcal{U} is a p -point.*

Proof. Let $\mathcal{B} \subseteq \mathcal{U}$ be a basis such that $|\mathcal{B}| < \mathfrak{d}$ and let $\{U_n : n \in \omega\} \subseteq \mathcal{B}$. We will find an $U \in \mathcal{U}$ such that, for each $n \in \omega$, $U \subseteq^* U_n$. We will assume that $U_n \subseteq U_m$ whenever $n > m$. For each $B \in \mathcal{B}$ define $f_B(n) = \min\{k + 1 : k \in U_n \cap B\}$. Then it follows that $\{f_B : B \in \mathcal{B}\}$ is not a dominating family. Let $f \in \omega^\omega$ be such that f is not dominated by any member of $\{f_B : B \in \mathcal{B}\}$. Define $U = \bigcup_{n \in \omega} (U_n \cap f(n))$. It is easy to see that, for each $n \in \omega$, $U \subseteq^* U_n$. It follows from the fact that f is not dominated by any member of $\{f_B : B \in \mathcal{B}\}$ that, for each $B \in \mathcal{B}$, $B \cap U$ is infinite and, as a consequence, $U \in \mathcal{U}$. \square

The cardinal \mathfrak{g} is closely related to strongly Michael ultrafilters, as seen in the following proposition.

Proposition 4.5.2. *Suppose that \mathcal{U} is a p -point such that $\chi(\mathcal{U}) < \mathfrak{g}$, then \mathcal{U} is not a strongly Michael ultrafilter.*

Proof. Let $K = \varphi(\mathcal{P}(\omega))$ be the compact set defined in lemma 4.3.1. We will show that $\omega < \mathfrak{d}_{\mathcal{U}}(K) \leq \chi(\mathcal{U})$:

($\omega < \mathfrak{d}_{\mathcal{U}}(K)$). Let $\{\varphi_{A_n} : n \in \omega\} \subseteq K_{\mathcal{P}(\omega)}$, we have to show that $\{\varphi_{A_n} : n \in \omega\} \subseteq K_{\mathcal{P}(\omega)}$ is not an $\leq_{\mathcal{U}}$ -dominating family inside K . For

each $n \in \omega$, pick $B_n \in \{A_n, \omega \setminus A_n\}$ such that $B_n \in \mathcal{U}$ and let $B \in \mathcal{U}$ be a pseudo-intersection of the B_n . It is routine to show that, for each $n \in \omega$, $\varphi_B \geq_{\mathcal{U}} \varphi_{A_n}$.

($\mathfrak{d}_{\mathcal{U}}(K) \leq \chi(U)$). If \mathcal{F} is a basis for \mathcal{U} , then it is easy to see that $\{\varphi_F : F \in \mathcal{F}\}$ is an $\leq_{\mathcal{U}}$ -dominant family inside $K_{\mathcal{P}(\omega)}$.

Finally, we can use the theorem 4.3.1 to show that $\omega < \mathfrak{d}_{\mathcal{U}}(K) < \mathfrak{d}_{\mathcal{U}}$. This shows that \mathcal{U} is not a strongly Michael ultrafilter. \square

The Rudin-Keisler and the Rudin Blass orders have been used to classify properties of ultrafilters, so it is natural to ask how Michael ultrafilters behaves with respect of these orders.

Proposition 4.5.3. *Suppose that \mathcal{U} and \mathcal{V} are ultrafilters such that $\mathcal{V} \leq_{\text{RK}} \mathcal{U}$, then, for every $K \subseteq \omega^\omega$ compact set, there is a compact set $K' \subseteq \omega^\omega$ such that $\mathfrak{d}_{\mathcal{U}}(K') = \mathfrak{d}_{\mathcal{V}}(K)$.*

Proof. Let $f : \omega \rightarrow \omega$ be the witness function for $\mathcal{V} \leq_{\text{RK}} \mathcal{U}$. Let $K \subseteq \omega^\omega$ be any compact set. Define $K' = \{g \circ f : g \in K\}$. Clearly K' is a compact set. We will show that, for each $h_0, h_1 \in \omega^\omega$, then $h_0 \leq_{\mathcal{V}} h_1$ if and only if $g \circ h_0 \leq_{\mathcal{U}} g \circ h_1$: Let $A = \{n \in \omega : h_0(n) \leq h_1(n)\}$. Then $A \in \mathcal{V}$ if and only if $f^{-1}(A) = \{n \in \omega : h_0 \circ f(n) \leq h_1 \circ f(n)\} \in \mathcal{U}$ and, as a consequence, $h_0 \leq_{\mathcal{V}} h_1$ if and only if $g \circ h_0 \leq_{\mathcal{U}} g \circ h_1$. From this observation, it is easy to deduce that $\mathcal{F} \subseteq K$ is $\leq_{\mathcal{V}}$ -dominating inside K if and only if $\mathcal{F} \circ f = \{g \circ f : g \in \mathcal{F}\} \subseteq K'$ is $\leq_{\mathcal{U}}$ -dominating inside K' . The conclusion follows immediately from the last statement. \square

From this proposition, it follows easily that everywhere Michael ultrafilters are closed downwards in the Rudin-Keisler order. An easy mutation of the last proof can be used to show that Michael ultrafilters are closed downwards. The behavior of strongly Michael ultrafilters might be more complicated:

Proposition 4.5.4. *Suppose that \mathcal{U} and \mathcal{V} are ultrafilters such that $\mathcal{V} \leq_{\text{RB}} \mathcal{U}$, then, $\mathfrak{d}_{\mathcal{V}} \leq \mathfrak{d}_{\mathcal{U}}$.*

Proof. Let $f : \omega \rightarrow \omega$ be the witness function for $\mathcal{V} \leq_{\text{RB}} \mathcal{U}$ and let $F \subseteq \omega^\omega$ be an $\leq_{\mathcal{U}}$ -dominating family. For each $g \in F$, let $g' : \omega \rightarrow \omega$ defined as $g'(k) = \max\{g(n) : n \in f^{-1}(k)\}$. We will show that $\{g' : g \in F\}$ is an $\leq_{\mathcal{V}}$ -dominating family: Let $h \in \omega^\omega$ and let $g \in F$ be such that $h \circ f \leq_{\mathcal{U}} g$.

We have to show that $h \leq_{\mathcal{V}} g'$. Let $A = \{n \in \omega : h(n) \leq g'(n)\}$. Then $A \in \mathcal{U}$ if and only if $\{n \in \omega : h \circ f(n) \leq g' \circ f(n)\} \in \mathcal{V}$. Observe that, for each $m \in \omega$, $g(m) \leq \max\{g(n) : f(n) = f(m)\} = g'(f(m))$ and therefore $f^{-1}(A)$ contains $\{n \in \omega : h \circ f(n) \leq g(n)\} \in \mathcal{V}$ which is an element of \mathcal{U} . \square

This implies immediately that Strongly Michael ultrafilters are closed downwards in the Rudin-Blass ordering. We do not know if they are closed under the Rudin-Keisler order.

We are ready to prove the following theorem.

Theorem 4.5.2. *Suppose that $\mathfrak{u} < \mathfrak{g}$, then there are no strongly Michael ultrafilters.*

Proof. Let \mathcal{U} be any ultrafilter and let \mathcal{V} be a p-point such that $\chi(\mathcal{V}) < \mathfrak{g}$. We know that \mathcal{U} and \mathcal{V} are nearly coherent, so there is a finite to one function f such that $f(\mathcal{U}) = f(\mathcal{V})$. Observe that $f(\mathcal{V})$ is a p-point such that $\chi(f(\mathcal{V})) < \mathfrak{g}$, and therefore $f(\mathcal{V})$ is not a strongly Michael filter. The conclusion follows from the fact that $f(\mathcal{V}) \leq_{\text{RB}} \mathcal{U}$. \square

A model that satisfies $\mathfrak{u} < \mathfrak{g}$ can be obtained by forcing with a countable support iteration of Miller's forcing (see [BJ95]). In this model the equality $\mathfrak{b} = \omega_1$ is satisfied, so there is a Michael space in this model. We do not know if there is a Michael ultrafilter in this model.

The main question of the existence of a Michael space still remains open. We finish this work with some questions regarding Michael ultrafilters:

Question 6. *Are the concepts of Michael ultrafilter and strongly Michael ultrafilter different?*

Under $\mathfrak{d} = \omega_1$, these concepts are the same (all ultrafilters are strongly Michael). We do not know if there can be a Michael ultrafilter that is not a strongly Michael ultrafilter.

Question 7. *Are there Michael ultrafilters? In particular, can they be found in the Mathias', Miller's or in Laver's model?*

There are no strongly Michael ultrafilters in the Miller's model, however we do not know if there are Michael ultrafilters in these models. This question is particularly important in the case of Mathias' and Laver's model, because it is still unknown if there is a Michael space in those models.

Question 8. *Is there a relation between rapid ultrafilters and Michael ultrafilters?*

Recall the compact set K that was used in Proposition 4.5.2. Suppose that \mathcal{U} is a rapid ultrafilter, we will show that $\mathfrak{d}_{\mathcal{U}}(K) \geq \mathfrak{b}$: Let $\kappa < \mathfrak{b}$ and let $\{\varphi_{A_\beta} : \beta \in \kappa\} \subseteq K$. Let $U = \{a_n : n \in \omega\} \in \mathcal{U}$ be such that, for every $\alpha < \kappa$ and for almost every $n \in \omega$, $(a_n, a_{n+1}) \cap A_\alpha$ has at least 1 element (this can be done with the characterization of \mathfrak{b} using partitions, see [BJ95]). Then it follows that $\varphi_U \geq_{\mathcal{U}} \varphi_{A_\alpha}$ for all $\alpha \in \kappa$. This, together with the facts that $\mathfrak{d}_{\mathcal{U}}(K) \leq \chi(\mathcal{U})$ and that $\chi(\mathcal{U}) \geq \mathfrak{d}$, shows that the argument that was given in Proposition 4.5.2 is going to be hard to replicate for q-points. We do not know if the existence of q-points imply the existence of a Michael ultrafilter.

Index

- F_σ sets, 3
- $F_{\sigma\delta}$ sets, 3
- G_δ sets, 3
- P^+ -filter, 20
- P^+ -filter according to \mathcal{B} , 37
- P^+ -tree ideal, 26
- $S_{fin}(\Omega, \Omega)$, 44
- $\chi(\mathcal{F})$, 7
- $\langle \kappa, \mathcal{I} \rangle$ -Luzin, 71
- \mathcal{B} -Canjar, 37
- \mathcal{I}^+ -tree of finite sets, 26
- ω -cover, 44
- ω^ω -bounding, 33
- σ - k -linked forcing, 58
- σ -algebra, 3
- σ -centered, 13
- σ -ideal, 7
- $f \leq_U g$, 84
- k -Sacks forcing, 61
- n -porous, 53
- Part*, 29

- additivity number $\text{add}(\mathcal{I})$, 11
- almost ω^ω -bounding, 40
- Almost contained, 9
- Almost disjoint family, 10
- almost disjoint family number \mathfrak{a} , 10
- amoeba forcing, 67
- anti-Sacks tree, k -anti-Sacks tree, 61
- antichain, 14

- Bernstein set, 6
- Borel determinacy, 5
- Borel sets, 3
- boundedness number \mathfrak{b} , 10
- branch of a tree, 4
- branching ideal \mathcal{I}_A , 44

- c.c.c. countable chain condition, 14
- Canjar filter, 20
- Canjar ideal, 20
- Canjar indestructible, 33
- cardinal μ , 88
- Cichoń's diagram, 12
- closed set, 2
- cofinality number $\text{cof}(\mathcal{I})$, 11
- cofinality of a ultrapower, 84
- Cohen forcing, 14
- Cohen model, 15
- Cohen real, 16
- coherent strong P^+ -ideal, 25
- compact space, 2
- completely Baire, 47
- concentrated set, 79
- covering number $\text{cov}(\mathcal{I})$, 11

- dense in forcing, 13
- determination, 5
- distributivity number \mathfrak{h} , 10
- dominating family, 10
- dominating number \mathfrak{d} , 10
- dominating number according to an ultrafilter, 84
- dominating real, 16
- Dual filter, 6
- Dual ideal, 6

- everywhere Michael ultrafilter, 88
 filter, 6
 Filter basis, 9
 Filter generated by, 7
 filter in forcing, 13
 forcing, 13

 games, 4
 generic filter, 13
 gradually fragmented ideals, 93

 Hechler forcing, 15
 Hechler model, 15
 hyperperfect, n -hyperperfect, 54

 ideal, 6
 ideal AS_k , 61
 Ideal generated by, 7
 independence number i , 11
 independent family, 11
 internal \mathcal{U} -dominating number, 85
 internal dominating number, 86
 internally unbounded, 89
 internally unbounded compact set, 89
 interval partition, 8

 Katetov order \leq_K , 7

 Laflamme game \mathcal{LF} , 45
 Laver forcing, 15
 Laver model, 15
 Laver property, 94
 Lindelöf degree number, 80
 Lindelöf space, 2
 localization property, 75
 lower porous, 51

 Lower semicontinuous submeasure (lscsm), 8
 Luzin set, 6

 MAD family, 10
 Martin number m , m_{σ} -centered, 14
 martin number m_k , 58
 Martin's Axiom, 14
 Mathias forcing, 15
 Mathias forcing relative to a filter, 19
 Mathias model, 15
 metric space, 2
 Michael sequence, 80
 Michael space, 78
 Michael ultrafilter, 85
 Miller forcing, 14
 Miller model, 15

 near coherence of filters, 95
 nearly coherent filters, 95
 nodes of a tree, 4
 nowhere dense set, 3

 open set, 2

 p -point, 8
 Polish space, 3
 porous set, 53
 porous tree, k -porous tree, 58
 Positive sets, 7
 productively Lindelöf, 77
 pruned tree, 4
 pseudointersection, 9
 pseudointersection number p , 9

 q -point, 8

 Ramsey ultrafilter, 8

- Random forcing, 14
- random model, 15
- Random real, 16
- reaping family, 10
- reaping number \mathfrak{r} , 10
- reduced Michael sequence, 80
- Rudin-Blass order \leq_{RB} , 7
- Rudin-Keisler order \leq_{RK} , 7

- Sacks forcing, 14
- Sacks model, 15
- Sacks property, 56
- Sacks tree, k -Sacks tree, 60
- selective ultrafilter, 8
- separable, 3
- set of branches $[T]$, 4
- splitting family, 10
- splitting nodes, 4
- splitting number \mathfrak{s} , 10
- stem, 4
- strategies, 5
- strong P^+ -ideal, 24
- Strongly Canjar, 38
- strongly Michael ultrafilters, 85
- strongly porous, 51
- strongly preserves $\text{non}(\mathbf{AS}_k)$, 64
- strongly preserves $\text{non}(\mathbf{SP}_k)$, 64

- the filter $\mathcal{F}^{<\omega}$, 20
- the ideal $\mathcal{I}^{<\omega}$, 20
- the ideals \mathbf{SP} , \mathbf{SP}_n , 54
- topological space, 1
- topology for, 1
- tree, 4

- Ultrafilter, 8
- ultrafilter number \mathfrak{u} , 9
- unbounded family, 10
- unbounded real, 16
- uniformity number $\text{non}(\mathcal{I})$, 11
- upper porous, 51

- Van Dowen's diagram, 11
- weakly ω^ω -bounding, 39

Bibliography

- [AG95] K. Alster and G. Gruenhagen. “Products of Lindelöf spaces and GO-spaces”. In: *Topology and its Applications* 64.1 (1995), pp. 23–36. ISSN: 0166-8641. DOI: [https://doi.org/10.1016/0166-8641\(94\)00068-E](https://doi.org/10.1016/0166-8641(94)00068-E). URL: <http://www.sciencedirect.com/science/article/pii/016686419400068E>.
- [Als90] K. Alster. “The Product of a Lindelöf Space with the Space of Irrationals Under Martin’s Axiom”. In: *Proceedings of the American Mathematical Society* 110.2 (1990), pp. 543–547. ISSN: 00029939, 10886826. URL: <http://www.jstor.org/stable/2048102>.
- [AM10] Uri Abraham and Menachem Magidor. “Cardinal arithmetic”. In: *Handbook of set theory. Vols. 1, 2, 3*. Dordrecht: Springer, 2010, pp. 1149–1227. DOI: [10.1007/978-1-4020-5764-9_15](https://doi.org/10.1007/978-1-4020-5764-9_15).
- [BEH78] C. L. Belna, M. J. Evans, and P. D. Humke. “Symmetric and ordinary differentiation”. In: *Proc. Amer. Math. Soc.* 72.2 (1978), pp. 261–267. ISSN: 0002-9939. DOI: [10.2307/2042787](https://doi.org/10.2307/2042787). URL: <http://dx.doi.org/10.2307/2042787>.
- [Bel81] Murray Bell. “On the combinatorial principle $P(c)$ ”. eng. In: *Fundamenta Mathematicae* 114.2 (1981), pp. 149–157. URL: <http://eudml.org/doc/211293>.
- [BF11] Jörg Brendle and Vera Fischer. “Mad families, splitting families and large continuum”. In: *J. Symbolic Logic* 76.1 (2011), pp. 198–208. ISSN: 0022-4812. DOI: [10.2178/jsl/1294170995](https://doi.org/10.2178/jsl/1294170995).

- [BHV13] Andreas Blass, Michael Hrušák, and Jonathan Verner. “On strong P -points”. In: *Proc. Amer. Math. Soc.* 141.8 (2013), pp. 2875–2883. ISSN: 0002-9939. DOI: [10.1090/S0002-9939-2013-11518-2](https://doi.org/10.1090/S0002-9939-2013-11518-2).
- [BJ95] Tomek Bartoszyński and Haim Judah. *Set theory. On the structure of the real line*. A K Peters, Ltd., Wellesley, MA, 1995, pp. xii+546. ISBN: 1-56881-044-X.
- [BL89] Andreas Blass and Claude Laflamme. “Consistency Results About Filters and the Number of Inequivalent Growth Types”. In: *J. Symbolic Logic* 54.1 (Mar. 1989), pp. 50–56. URL: <https://projecteuclid.org/443/euclid.jsl/1183742850>.
- [Bla10] Andreas Blass. “Combinatorial cardinal characteristics of the continuum”. In: *Handbook of set theory. Vols. 1, 2, 3*. Dordrecht: Springer, 2010, pp. 395–489. DOI: [10.1007/978-1-4020-5764-9_7](https://doi.org/10.1007/978-1-4020-5764-9_7).
- [Bla86] Andreas Blass. “Near coherence of filters. I. Cofinal equivalence of models of arithmetic.” In: *Notre Dame J. Formal Logic* 27.4 (Oct. 1986), pp. 579–591. DOI: [10.1305/ndjfl/1093636772](https://doi.org/10.1305/ndjfl/1093636772). URL: <https://doi.org/10.1305/ndjfl/1093636772>.
- [BM99] Andreas Blass and Heike Mildenerger. “On the Cofinality of Ultrapowers”. In: *J. Symbolic Logic* 64.2 (June 1999), pp. 727–736. URL: <https://projecteuclid.org/443/euclid.jsl/1183745804>.
- [BR] Jörg Brendle and Dilip Raghavan. “Bounding Splitting and Almost Disjointness”. In: *preprint* ().
- [Bre96] Jörg Brendle. “The additivity of porosity ideals”. In: *Proc. Amer. Math. Soc.* 124.1 (1996), pp. 285–290. ISSN: 0002-9939. DOI: [10.1090/S0002-9939-96-02992-9](https://doi.org/10.1090/S0002-9939-96-02992-9). URL: <http://dx.doi.org/10.1090/S0002-9939-96-02992-9>.
- [Bre98] Jörg Brendle. “Mob families and mad families”. In: *Arch. Math. Log.* 37.3 (1998), pp. 183–197.

- [BS03] Jörg Brendle and Saharon Shelah. “Evasion and prediction”. In: *Arch. Math. Log.* 42.4 (2003), pp. 349–360. DOI: [10.1007/s001530200143](https://doi.org/10.1007/s001530200143). URL: <http://dx.doi.org/10.1007/s001530200143>.
- [Can88] R. Michael Canjar. “Mathias forcing which does not add dominating reals”. In: *Proc. Amer. Math. Soc.* 104.4 (1988), pp. 1239–1248. ISSN: 0002-9939. DOI: [10.2307/2047620](https://doi.org/10.2307/2047620).
- [Can89] R. Michael Canjar. “Cofinalities of countable ultraproducts: the existence theorem.” In: *Notre Dame J. Formal Logic* 30.4 (Sept. 1989), pp. 539–542. DOI: [10.1305/ndjfl/1093635237](https://doi.org/10.1305/ndjfl/1093635237). URL: <https://doi.org/10.1305/ndjfl/1093635237>.
- [Coh63] P.J. Cohen. “The independence of the continuum hypothesis”. In: *Proceedings of the National Academy of Sciences of the United States of America*, 50(6) (1963), pp. 1143–1148.
- [Coh64] P.J. Cohen. “The independence of the continuum hypothesis II”. In: *Proceedings of the National Academy of Sciences of the United States of America*, 51(1) (1964), pp. 105–110.
- [DCZ] Dusan Repovs David Chodounsky and Lyubomyr Zdomsky. “MATHIAS FORCING AND COMBINATORIAL COVERING PROPERTIES OF FILTERS”. In: *preprint* ().
- [Den41] A. Denjoy. “Leçons sur le Calcul des Coefficients d’une Série Trigonométrique”. In: *Gauthier-Villars* (1941).
- [Dol67] E. P. Dolženko. “Boundary properties of arbitrary functions”. In: *Izv. Akad. Nauk SSSR Ser. Mat.* 31 (1967), pp. 3–14. ISSN: 0373-2436.
- [Dou84] Eric K. van Douwen. “The Integers and Topology”. In: (Dec. 1984).
- [Dow88] Alan Dow. “An introduction to applications of elementary submodels to topology”. In: *Topology Proc.* 13(1) (1988), pp. 17–72.

- [Eng77] R. Engelking. *General topology*. Monografie matematyczne. PWN, 1977. URL: <https://books.google.com.mx/books?id=h4FsAAAAMAAJ>.
- [Far96] Ilijas Farah. "OCA and towers in $P(N)/fin$ ". In: 37 (Jan. 1996).
- [GHMC] Osvaldo Guzmán, Michael Hrušák, and Arturo Martínez-Celis. "Cardinal Invariants of Strongly Porous Sets". In: *to appear in the journal of logic and analysis* ().
- [GHMC14] Osvaldo Guzmán, Michael Hrušák, and Arturo Martínez-Celis. "Canjar filters II: Proofs of $\mathfrak{b} < \mathfrak{s}$ and $\mathfrak{b} < \mathfrak{a}$ revisited". In: *RIMS proceedings* (2014), pp. 59–67.
- [GHMC17] Osvaldo Guzmán, Michael Hrušák, and Arturo Martínez-Celis. "Canjar Filters". In: *Notre Dame J. Formal Logic* 58.1 (2017), pp. 79–95. DOI: [10.1215/00294527-3496040](https://doi.org/10.1215/00294527-3496040). URL: <https://doi.org/10.1215/00294527-3496040>.
- [HH] Michael Hrušák and Minami Hiroaki. "Laver-Prikry and Mathias-Prikry type forcings". In: *To appear in Annals of Pure and Applied Logic* ().
- [HHH07] Fernando Hernández-Hernández and Michael Hrušák. "Cardinal Invariants of Analytic P -Ideals". In: 59 (June 2007), pp. 575–595.
- [HM07] Michael Hrušák and Justin Tatch Moore. "Chapter 10 - Introduction: Twenty problems in set-theoretic topology". In: *Open Problems in Topology {II}*. Ed. by Elliott Pearl. Amsterdam: Elsevier, 2007, pp. 111–113. ISBN: 978-0-444-52208-5. DOI: <https://doi.org/10.1016/B978-044452208-5/50010-7>. URL: <https://www.sciencedirect.com/science/article/pii/B9780444522085500107>.
- [HMA11] Michael Hrušák and David Meza-Alcántara. "Comparison game on Borel ideals". In: *Comment. Math. Univ. Carolin.* 52.2 (2011), pp. 191–204. ISSN: 0010-2628.

- [HRRZ14] Michael Hrušák, Diego Rojas-Rebolledo, and Jindřich Zapletal. “Cofinalities of Borel ideals”. In: *Mathematical Logic Quarterly* 60.1-2 (2014), pp. 31–39. ISSN: 1521-3870. DOI: [10.1002/malq.201200079](https://doi.org/10.1002/malq.201200079). URL: <http://dx.doi.org/10.1002/malq.201200079>.
- [Hru11] Michael Hrušák. “Combinatorics of filters and ideals”. In: *Set theory and its applications*. Vol. 533. Contemp. Math. Providence, RI: Amer. Math. Soc., 2011, pp. 29–69. DOI: [10.1090/conm/533/10503](https://doi.org/10.1090/conm/533/10503).
- [HZ12] Michael Hrušák and Ondřej Zindulka. “Cardinal invariants of monotone and porous sets”. In: *J. Symbolic Logic* 77.1 (2012), pp. 159–173. ISSN: 0022-4812. DOI: [10.2178/jsl/1327068697](https://doi.org/10.2178/jsl/1327068697). URL: <http://dx.doi.org/10.2178/jsl/1327068697>.
- [Kec95] Alexander S. Kechris. *Classical descriptive set theory*. Vol. 156. Graduate Texts in Mathematics. New York: Springer-Verlag, 1995, pp. xviii+402. ISBN: 0-387-94374-9. DOI: [10.1007/978-1-4612-4190-4](https://doi.org/10.1007/978-1-4612-4190-4).
- [KLW87] A. S. Kechris, A. Louveau, and W. H. Woodin. “The structure of σ -ideals of compact sets”. In: *Trans. Amer. Math. Soc.* 301.1 (1987), pp. 263–288. ISSN: 0002-9947. DOI: [10.2307/2000338](https://doi.org/10.2307/2000338).
- [Kun80] Kenneth Kunen. *Set theory*. Vol. 102. Studies in Logic and the Foundations of Mathematics. An introduction to independence proofs. North-Holland Publishing Co., Amsterdam-New York, 1980, pp. xvi+313. ISBN: 0-444-85401-0.
- [Laf89] Claude Laflamme. “Forcing with filters and complete combinatorics”. In: *Ann. Pure Appl. Logic* 42.2 (1989), pp. 125–163. ISSN: 0168-0072. DOI: [10.1016/0168-0072\(89\)90052-3](https://doi.org/10.1016/0168-0072(89)90052-3).
- [LL02] Claude Laflamme and Christopher C. Leary. “Filter games on ω and the dual ideal”. In: *Fund. Math.* 173.2 (2002), pp. 159–173. ISSN: 0016-2736. DOI: [10.4064/fm173-2-4](https://doi.org/10.4064/fm173-2-4).

- [LP03] Joram Lindenstrauss and David Preiss. “On Fréchet differentiability of Lipschitz maps between Banach spaces”. In: *Ann. of Math. (2)* 157.1 (2003), pp. 257–288. ISSN: 0003-486X. DOI: [10.4007/annals.2003.157.257](https://doi.org/10.4007/annals.2003.157.257). URL: <http://dx.doi.org/10.4007/annals.2003.157.257>.
- [LV99] Alain Louveau and Boban Velickovic. “Analytic ideals and cofinal types”. In: *Ann. Pure Appl. Logic* 99.1-3 (1999), pp. 171–195. ISSN: 0168-0072. DOI: [10.1016/S0168-0072\(98\)00065-7](https://doi.org/10.1016/S0168-0072(98)00065-7).
- [Mar75] Donald A. Martin. “Borel Determinacy”. In: *Annals of Mathematics* 102.2 (1975), pp. 363–371. ISSN: 0003486X. URL: <http://www.jstor.org/stable/1971035>.
- [Maz00] Krzysztof Mazur. “A Modification of Louveau and Velickovic’s Construction for F_σ -Ideals”. In: *Proceedings of the American Mathematical Society* 128.5 (2000), pp. 1475–1479. ISSN: 00029939, 10886826. URL: <http://www.jstor.org/stable/119661>.
- [Maz91] Krzysztof Mazur. “ F_σ -ideals and $\omega_1\omega_1^*$ -gaps in the Boolean algebras $P(\omega)/I$ ”. In: *Fund. Math.* 138.2 (1991), pp. 103–111. ISSN: 0016-2736.
- [MC90] R Michael Canjar. “On the Generic Existence of Special Ultrafilters”. In: 110 (Sept. 1990), pp. 233–233.
- [MHD04] Justin Tatch Moore, Michael Hrušák, and Mirna Džamonja. “Parametrized \diamond principles”. In: *Trans. Amer. Math. Soc.* 356.6 (2004), pp. 2281–2306. ISSN: 0002-9947. DOI: [10.1090/S0002-9947-03-03446-9](https://doi.org/10.1090/S0002-9947-03-03446-9).
- [Mic63] E. Michael. “The product of a normal space and a metric space need not be normal”. In: *Bull. Amer. Math. Soc.* 69.3 (May 1963), pp. 375–376. URL: <https://projecteuclid.org:443/euclid.bams/1183525263>.

- [Mic71] Ernest A. Michael. "Paracompactness and the Lindelöf property in finite and countable cartesian products". eng. In: *Compositio Mathematica* 23.2 (1971), pp. 199–214. URL: <http://eudml.org/doc/89084>.
- [Mil01] Jan van Mill. *The infinite-dimensional topology of function spaces*. Vol. 64. North-Holland Mathematical Library. Amsterdam: North-Holland Publishing Co., 2001, pp. xii+630. ISBN: 0-444-50557-1.
- [Moo99] J. Tatch Moore. "Some of the combinatorics related to Michael's problem". In: *Proc. Amer. Math. Soc.* 127 (1999), pp. 2459–2467.
- [NR93] L. Newelski and A. Rosłanowski. "The ideal determined by the unsymmetric game". In: *Proc. Amer. Math. Soc.* 117.3 (1993), pp. 823–831. ISSN: 0002-9939. DOI: [10 . 2307 / 2159150](https://doi.org/10.2307/2159150). URL: <http://dx.doi.org/10.2307/2159150>.
- [Nyi92] Peter J. Nyikos. "Subsets of ${}^{\omega}\omega$ and the Fréchet-Urysohn and α_i -properties". In: *Topology Appl.* 48.2 (1992), pp. 91–116. ISSN: 0166-8641. DOI: [10 . 1016 / 0166 - 8641 \(92 \) 90021 - Q](https://doi.org/10.1016/0166-8641(92)90021-Q).
- [Oxt13] J.C. Oxtoby. *Measure and Category: A Survey of the Analogies between Topological and Measure Spaces*. Graduate Texts in Mathematics. Springer New York, 2013. ISBN: 9781468493399. URL: https://books.google.com.mx/books?id=Va_aBwAAQBAJ.
- [PZ84] D. Preiss and L. Zajíček. "Fréchet differentiation of convex functions in a Banach space with a separable dual". In: *Proc. Amer. Math. Soc.* 91.2 (1984), pp. 202–204. ISSN: 0002-9939. DOI: [10 . 2307 / 2044627](https://doi.org/10.2307/2044627). URL: <http://dx.doi.org/10.2307/2044627>.
- [Ren95] Dave L. Renfro. "Porosity, nowhere dense sets and a theorem of Denjoy". In: *Real Anal. Exchange* 21.2 (1995/96), pp. 572–581. ISSN: 0147-1937.

- [Rep89] M. Repický. “Porous sets and additivity of Lebesgue measure”. In: *Real Anal. Exchange* 15.1 (1989/90), pp. 282–298. ISSN: 0147-1937.
- [Rep90] M. Repický. “Additivity of porous sets”. In: *Real Anal. Exchange* 16.1 (1990/91), pp. 340–343. ISSN: 0147-1937.
- [Rep93] Miroslav Repický. “Cardinal invariants related to porous sets”. In: *Set theory of the reals (Ramat Gan, 1991)*. Vol. 6. Israel Math. Conf. Proc. Bar-Ilan Univ., Ramat Gan, 1993, pp. 433–438.
- [RZ01] Simeon Reich and Alexander J. Zaslavski. “Well-posedness and porosity in best approximation problems”. In: *Topol. Methods Nonlinear Anal.* 18.2 (2001), pp. 395–408. ISSN: 1230-3429.
- [She98] Saharon Shelah. *Proper and improper forcing*. Second. Perspectives in Mathematical Logic. Berlin: Springer-Verlag, 1998, pp. xlviii+1020. ISBN: 3-540-51700-6.
- [Sol94] Slawomir Solecki. “Covering Analytic Sets by Families of Closed Sets”. In: *J. Symbolic Logic* 59.3 (Sept. 1994), pp. 1022–1031. URL: <https://projecteuclid.org/443/euclid.jsl/1183744566>.
- [SS] Masami Sakai and Marion Scheepers. “The combinatorics of open covers”. In: *To appear in Recent Progress on General Topology III* ().
- [Tal11] Franklin D. Tall. “Productively Lindelöf spaces may all be D”. In: (2011).
- [TF95] S. Todorchevich and I. Farah. *Some applications of the method of forcing*. Yenisei Series in Pure and Applied Mathematics. Yenisei, Moscow, 1995, pp. iv+148. ISBN: 5-88623-014-9.
- [Voj93] Peter Vojtáš. “Generalized Galois-Tukey-connections between explicit relations on classical objects of real analysis”. In: 6 (Jan. 1993).

- [Zap08] Jindřich Zapletal. *Forcing idealized*. Vol. 174. Cambridge Tracts in Mathematics. Cambridge University Press, Cambridge, 2008, pp. vi+314. ISBN: 978-0-521-87426-7. DOI: [10.1017/CBO9780511542732](https://doi.org/10.1017/CBO9780511542732). URL: <http://dx.doi.org/10.1017/CBO9780511542732>.
- [Zas01] Alexander J. Zaslavski. "Well-posedness and porosity in optimal control without convexity assumptions". In: *Calc. Var. Partial Differential Equations* 13.3 (2001), pp. 265–293. ISSN: 0944-2669. DOI: [10.1007/s005260000073](https://doi.org/10.1007/s005260000073). URL: <http://dx.doi.org/10.1007/s005260000073>.