



UNIVERSIDAD NACIONAL AUTÓNOMA DE MÉXICO
PROGRAMA DE MAESTRÍA Y DOCTORADO EN INGENIERÍA
INGENIERÍA ELÉCTRICA – CONTROL

OUTPUT-FEEDBACK SLIDING-MODE CONTROL
WITH INPUT-TO-STATE STABILITY

TESIS
QUE PARA OPTAR POR EL GRADO DE:
DOCTORA EN INGENIERÍA

PRESENTA:
ANDREA APARICIO MARTÍNEZ

TUTOR PRINCIPAL
DR. LEONID FRIDMAN, FACULTAD DE INGENIERÍA, UNAM
COMITÉ TUTOR
DR. FERNANDO CASTAÑOS, CINVESTAV
DR. JAIME A. MORENO, INSTITUTO DE INGENIERÍA

CDMX, FEBRERO 2017



Universidad Nacional
Autónoma de México

Dirección General de Bibliotecas de la UNAM

Biblioteca Central



UNAM – Dirección General de Bibliotecas
Tesis Digitales
Restricciones de uso

DERECHOS RESERVADOS ©
PROHIBIDA SU REPRODUCCIÓN TOTAL O PARCIAL

Todo el material contenido en esta tesis esta protegido por la Ley Federal del Derecho de Autor (LFDA) de los Estados Unidos Mexicanos (México).

El uso de imágenes, fragmentos de videos, y demás material que sea objeto de protección de los derechos de autor, será exclusivamente para fines educativos e informativos y deberá citar la fuente donde la obtuvo mencionando el autor o autores. Cualquier uso distinto como el lucro, reproducción, edición o modificación, será perseguido y sancionado por el respectivo titular de los Derechos de Autor.

JURADO ASIGNADO:

Presidente:

Dr. Gerardo René Espinosa Pérez

Secretario:

Dr. Luis A. Alvarez Icaza Longoria

Vocal:

Dr. Leonid Fridman

1 er. Suplente:

Dr. Jaime Alberto Moreno Pérez

2 d o. Suplente:

Dr. Fernando Castaños Luna

Lugar o lugares donde se realizó la tesis: CDMX

TUTOR DE TESIS:
DR. LEONID FRIDMAN

FIRMA

A mis padres.

Agradecimientos.

A mis padres y hermano, por su apoyo incondicional, ejemplo y consejo.

Al Dr. Leonid Fridman, por su disposición y dirección.

Al Dr. Fernando Castaños, especialmente, cuya participación fue fundamental para el desarrollo de esta tesis.

A los miembros de mi comité tutorial y sinodales por sus valiosas observaciones y consejos.

A mis compañeros del grupo de modos deslizantes, siempre dispuestos a escuchar, comentar y aportar ideas.

Al CONACyT y al Posgrado en Ingeniería Eléctrica de la UNAM.

Abstract

This work attacks the problem of taking to zero the trajectories of a linear system of any relative degree, of which only partial state information is available (output feedback), with unstable zero dynamics, in absence of perturbations. In presence of bounded matched and unmatched perturbations of which a bound is not necessarily known, the trajectories should converge to a neighborhood of the origin. The control strategy includes the design of a surface such that when the solutions of the system slide over it, the nominal zero dynamics becomes globally asymptotically stable, and its input-to-state stability (ISS) property is established. Also, a conventional sliding-mode controller with an added linear term, and a Super-Twisting algorithm are implemented as control laws. For both of these controllers, the ISS property is investigated, which is a rather unexplored ground for sliding-mode controllers. Conditions for the gains of the controllers, and the parameters of the sliding variable are established through ISS-Lyapunov functions and a small gain theorem.

Contents

Dedicatoria	iii
Abstract	v
Table of Contents	vii
1 Introduction	1
1.1 State of the Art	3
1.1.1 Output-Feedback Sliding-Modes	3
1.1.2 Input-to-State Stability	4
1.1.3 Regular and Normal Forms	5
1.2 Motivation and Problem Statement	6
1.3 Organization of the Document	9
1.4 Preliminaries	10
1.4.1 Notation	10
1.4.2 Definitions and Mathematical Tools	11
2 Sliding Surface Design	15
2.1 Output Normal Form	16
2.2 Reduced Order System	19
2.3 Virtual Control Design	21
2.4 Relative Degree r Sliding Surface	23
2.5 Relative Degree One Sliding Surface	25
3 Perturbations and External Inputs	29
3.1 Unperturbed case	30
3.2 Relative Degree Condition	30
3.3 Lipschitz condition	33
3.4 Parameter Choice and Design Tradeoff	36
3.4.1 Priority to the Control	40
3.4.2 Priority to the State	42

4	Sliding Mode Control with ISS Properties	45
4.1	Conventional Sliding Mode Controller with added linear term	47
4.1.1	Example and Numerical Simulations	50
4.2	Super Twisting Controller	57
4.2.1	Example and Numerical Simulations	62
5	Stabilization of switched systems by linear feedbacks and its ISS properties	67
5.1	Stability of an n -dimensional system with n signs	68
5.2	Perturbation Analysis and Input to State Stability	70
5.2.1	Example	72
5.3	Stabilization of chain of integrators by n -sign feedback by the design of the switching surfaces	74
5.3.1	State transformation to a new set of coordinates	75
5.3.2	Convergence to the origin of an n -signs controller	77
5.3.3	Convergence to the origin of an n -sign controller with an added linear term	83
5.3.4	Example	84
6	Conclusions	87
6.1	Concluding Remarks	87
6.2	List of Publications	89
	Bibliography	93

Chapter 1

Introduction

This work has been developed following the interest of studying three different subjects in control theory and some open problems within them.

In the first place, the output-feedback (OF) problem which is a topic that has interested the control community because it is directly related to an implementation issue. This issue raises from the fact that, frequently, the use of sensors can be either expensive or troublesome due to the nature of the hardware. This leads to the recurrent problem of systems that must be controlled with only partial state information. Many efforts have been dedicated to try to solve the mentioned problem, and the results have derived in two main branches: the design of state observers, and the development of output-feedback control strategies. One disadvantage of the first approach is that in many cases the separation principle does not hold and it is not possible to design separately a controller and an observer that feeds it. Also, the robustness of a controller against perturbations is usually lost when it is connected directly to an observer. The task becomes more complicated when there are uncertainties in the model, or perturbations that affect the dynamics.

Secondly, the features and flaws of the sliding-mode controllers (SMC). Since their appearance, in the second half of the past century, they have gained a great deal of attention from the control community due to their simple structure and some very interesting properties. Among some of the most attiring ones are their robustness against disturbances that can be assumed to be bounded and matched to the control input. Also, this kind of controllers can be implemented when there are uncertainties in the model of the system, or even when this model is not available. Another very interesting feature is that the sliding-mode controllers can provide finite-time convergence to a designed surface. This surface is called the sliding surface, and is normally specifically constructed by the designer so that when the trajectories of the system slide on it, they follow a desired dynamic behavior. The downside in the use of the sliding-mode controllers is that their robustness is severely compromised when a bound for the disturbance cannot be known, or when they are unmatched to the control input. Another disadvantage of the systems governed by sliding-mode controllers is that they may loose their robustness properties when directly connected to other systems, for example, observers.

Thirdly, the interest to understand the behavior of dynamic systems with different inputs, which has been a frequent subject of investigations throughout the history of control. These inputs can be signals that come from interconnections with other dynamic systems, perturbations, noise, or even control laws. Many efforts have been dedicated to answer questions such as what kind of inputs will let a stable system maintain this property, and how to characterize this stability. In particular, the study of these topics for non-linear systems has aroused a lot of interest. At the end of the eighties the first notions that answered these questions appeared, and were gathered under the name of input-to-state stability (ISS), and many advances have been made in the field since then.

This work investigates the cases and conditions under which the sliding-mode controllers can solve the output-feedback problem, by means of the design of the sliding surface, using a Lyapunov-ISS approach.

1.1 State of the Art

1.1.1 Output-Feedback Sliding-Modes

The problem of output-feedback sliding-modes has been addressed in a great number of works with different approaches. The main results found in the literature can be separated into four groups, depending on some system's characteristics that they consider, and the control objective that they pursue:

- **Control objective:** The control objective of the output-feedback results can be divided in two: those that aim to bring the output signal to zero, and keep it there for all future time, and those that seek to bring the complete state to a neighborhood of the origin, despite of the perturbations.
- **Relative degree of the output:** The majority of the results can be applied to systems with outputs of relative degree one, that is, that the control input can be found in the first derivative of the measured state. Some work has also been done in order to try to overcome this restriction.
- **Perturbations:** A classical restriction imposed over systems for which sliding-mode controllers are implemented, is that the perturbations should be matched to the control input, and bounded by a known constant. Some efforts have been dedicated to consider unmatched perturbations as well.
- **Observability:** Even though the direct design of state observers is most of the times considered to be in a different path than the output-feedback control strategies, the observability property is still a fundamental requirement for the development of the

latter. In some cases it is only required that the system is observable, but in some others this is not enough, and the system must be strongly observable.

Many good results for the cases when the relative degree of the output is equal to one with matched perturbations can be found, being [Bag97] one of the most representative. In this work, the construction of dynamic compensators is proposed in order to add dynamics to systems for which a direct pole assignment cannot be done (the Kimura-Davidson condition [Kimura75] is not satisfied). Since this case is not in the scope of the present work, we will not focus any further into it.

For the case when unmatched perturbations are present in the system, [Choi08] and [Castaños11] describe a method for combining SM and H_∞ , with the purpose of attenuating them, i.e. keeping the complete state in a neighborhood of the origin. In the first, the existence conditions for a sliding surface are found via linear matrix inequalities, which unfortunately increments the computational effort needed. The second proposes the design of an H_∞ controller for a reduced order system. Nevertheless, these two approaches only admit relative degree one outputs.

When the control objective is to keep the output at zero, in spite of unmatched perturbations, in [Davila13] [Ferreira14] and [Ferreira15] can be found results that combine backstepping with higher order sliding-modes. These approaches require that the system is strongly observable whereas in all the mentioned above the requirement is of observability only.

1.1.2 Input-to-State Stability

The input-to-state stability theory, that first appeared in the eighties, establishes conditions under which a norm (usually Euclidean or supremum) of the states is eventually bounded by the norm of its inputs, and goes to zero when the norm of the inputs does

[Sontag95].

Many advances in the ISS theory were made in the following decades, for example, establishing the sufficient and necessary conditions to characterize a system as ISS [Sontag95, Dashkovskiy11a]. Also, the interconnection of systems has been a central subject in many works, resulting in some useful and widely known theorems such as a Lyapunov-based nonlinear small gain theorem [Jiang96], or a small gain theorem for systems with mixed ISS characterizations [Dashkovskiy11b]. On the other hand, many Lyapunov approaches have been developed to facilitate the ISS analysis by means of Lyapunov functions [Sontag99]. These advances have led to the discovery of many applications to the ISS theory.

Recently, the ISS theory has incorporated a new concept: the integral input-to-state stability (iISS), allowing inputs to be bounded by an integral norm and states by a supremum one [Angeli00]. This new concept enriches the ISS theory by allowing to characterize the stability of a broader class of systems that could not be characterized as ISS, such as the conventional (first-order) sliding-mode controller with constant gain. This approach, however, is still largely unexplored and its implementation can be complicated. A methodology that has proven to facilitate the ISS and iISS analysis is the weighted homogeneity [Bernuau13], which is very convenient for some sliding-mode algorithms with an homogeneous nature. The disadvantage of this approach is that, although ISS can be established on homogeneous grounds, it is still impossible to calculate an iISS or an ISS gain.

1.1.3 Regular and Normal Forms

In the early eighties regular forms were introduced in [Luk'yanov81, Utkin92], and have been widely used as a way of simplifying the selection of sliding manifolds and control laws. These forms offer a simple visualization of system properties, dividing the

system in two: a subsystem that contains the control and another subsystem that does not. It is worth mentioning that in order to implement a sliding-mode control on a system in regular form, the complete state must be measured. In the nineties, the backstepping theory was developed [Kanellakopoulos92], and a similar two stage technique that also requires complete knowledge of the state appeared.

The normal form that appears in [Isidori95] follows the same idea as the regular forms, in the sense that it separates the system into the part that contains the control input, and the part that does not, but taking into account the case when the system has an output.

In [Khalil02] (pg. 596), a special case of the normal form where the system is in strict feedback form, and the internal dynamics receive the output signal as an *input*, is briefly mentioned. This form is used to illustrate the utility of the backstepping technique for a particular case of the system's characteristics.

One of the main contributions of [Castaños11] is the introduction of an output-based regular form, for a system with an output of relative degree one. This form coincides with the one mentioned in the above paragraph.

1.2 Motivation and Problem Statement

Consider a system

$$\begin{aligned} \dot{x} &= Ax + Bv + Dw \\ y &= Cx, \end{aligned} \tag{1.1}$$

where $x \in \mathbb{R}^n$ is the state, $v \in \mathbb{R}$ is the control input, $y \in \mathbb{R}$ is the measured output of relative degree r with respect to v , and $w \in \mathbb{R}^q$ with $0 \leq q \leq n$, is a bounded disturbance. For simplicity, along this document the SISO case is considered, but all the calculations can

also be done for the MIMO case. The output y is assumed to be a noiseless measurement¹. It is clear that if system (1.1) is of dimension $n > 1$, being y of dimension one, there is part of the state that cannot be recovered by purely algebraic means and thus, a problem of output-feedback is addressed.

As was mentioned in Section 1.1, the results on Output-Feedback Sliding-Modes (OFSM) that consider both matched and unmatched perturbations can be divided in two large groups, as shown in Figure 1.1.

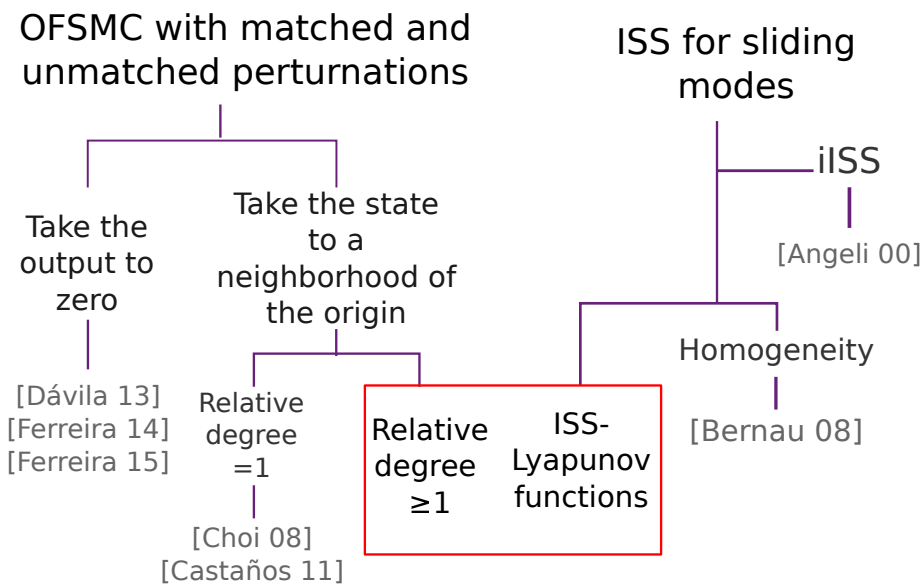

Figure 1.1: Output-feedback sliding-modes with matched and unmatched perturbations, and ISS for sliding-modes

As was mentioned in Section 1.1, there are two open problems in the subjects of OFSM with matched and unmatched disturbances, and ISS for sliding-modes. On one hand, the case when the relative degree is equal or greater than one, when matched and

¹For the general case it is assumed that the measurement is free of perturbations or noise, however, in the perturbation analysis section it will be discussed in which cases and what kind of measurement noise could be admitted.

unmatched perturbations are present and, on the other, the problem of proving the ISS property of SM algorithms via ISS-Lyapunov functions. The present work attacks the intersection of this two open problems, as is illustrated in Figure 1.1.

The objective of this work is to propose a control strategy such that the trajectories of system (1.1), with $r \geq 1$, can be globally and asymptotically taken to the origin, despite the magnitude of the initial conditions, in absence of disturbances. In presence of disturbances (matched and unmatched) the trajectories should globally converge to a vicinity of the origin. A parallel objective is to explore the ISS properties of the SMC, in order to establish the stability conditions under this point of view.

The main contributions of this work is a linear transformation that takes a system into an output based normal form, without loss of generality, for any relative degree, the design of a surface that guarantees the stabilization of the zero dynamics, if there are any, and the ISS Lyapunov-based analysis of a system with an arbitrary relative degree output and unstable zero dynamics, governed by sliding-mode controllers. This analysis leads to the introduction of control laws, and conditions for their gains that guarantee global convergence to a neighborhood of the origin of the trajectories of (1.1).

In the next chapters the following unperturbed case will be considered:

$$\begin{aligned}\dot{x} &= Ax + Bv \\ y &= Cx,\end{aligned}\tag{1.2}$$

This particular case is used in order to explain the methodology for assessing the output-feedback problem more clearly. Afterwards, the perturbations will be taken into account, and the control law will be designed using the general perturbed case.

1.3 Organization of the Document

The organization of the rest of this document is as follows:

Section 1.4 of this chapter contains the notation used in this document, as well as definitions and known results that are useful for the development of the work.

Chapter 2 is devoted to the construction of a sliding surface for the system presented in the problem statement. The procedure to do this includes the proposal of a transformation that takes the coordinates of a linear system into an output based normal form -referred to as Output Normal Form (ONF)-, without loss of generality; the definition of a reduced order system, which contains the zero dynamics of the transformed system; and the proof of its observability and controllability properties. Also, an observer for this reduced order system is defined, and a control law that depends on the observer. This control law translates into a virtual control for the zero dynamics that depends on the output of the original system. Finally, a sliding variable of relative degree r is defined, such that when it is forced to zero, along with its first r time derivatives, it is assured that the virtual control acts on the zero dynamics as designed. Afterwards, a relative degree one sliding variable is presented, with the same properties.

As mentioned in Section 1.2, the analysis performed in Chapter 2 is done for the unperturbed case of the system. In Chapter 3 the external inputs and perturbations admitted by the methodology presented in this work are defined, and a method for choosing the parameters of the observer and the virtual controller is presented. The way of choosing the parameters will depend on the type of perturbations present, and also on the performance objectives.

In Chapter 4 the ISS properties of two Sliding-Mode controllers are analyzed, and conditions to guarantee the stability of the complete solution are established through them. These two controllers are a conventional sliding-mode controller with an added linear term, and a Super Twisting controller. For both of them an example is provided, that also shows the methodology presented in the past sections. The theoretical results are validated through some numerical simulations.

Chapter 5 presents the results obtained from a collaboration with the Non-A team from INRIA, Lille in France, regarding the linear stabilization of switched systems. This topic falls out of the Output-Feedback problem, but represents a contribution on the ISS property of higher-order sliding-mode controllers.

Finally, Chapter 6 includes some concluding remarks of this work, and mentions the publications made, as well as the ones that are under revision and those that are currently in preparation.

1.4 Preliminaries

1.4.1 Notation

- The elementwise application of an operator \bullet to a vector
- I_n denotes the Identity matrix of dimension n ;
- $\text{diag}(A)$ represents a matrix where the main diagonal is the same as that of matrix A and every other element is equal to zero;
- $\vec{a}_{(n \times s)}$, for a constant a represents a matrix of dimension $n \times s$, whose every element is equal to a ;
- $A^{[i]}$ denotes the i th column of a matrix A ;

- A_n^{int} represents a square matrix of size n whose every element is equal to zero, except for the diagonal above the main one, which is composed of ones;
- $\lambda(A)$ represents the vector of eigenvalues of a matrix A , and $\lambda_{\min}(A)$ and $\lambda_{\max}(A)$ represent the minimal and the maximal values of this vector, respectively;
- $|a|$ represents the absolute value of a scalar a ;
- $\|v\|$ denotes the Euclidean norm of a vector $v \in \mathbb{R}^n$, $\|v\|_1 = \sum_{i=1}^n |v_i|$ and $\|v\|_\infty = \max_{1 \leq i \leq n} |v_i|$;
- $\|A\|$ represents the Euclidean induced norm of a matrix $A \in \mathbb{R}^{n \times s}$, while $\|A\|_1 = \max_{1 \leq i \leq s} \|A^{[i]}\|_1$ and $\|A\|_\infty = \|A^T\|_1$;
- For a matrix $A \in \mathbb{R}^{n \times s}$ the following norm equivalences hold [Horn90]

$$\frac{1}{\sqrt{n}} \|A\|_1 \leq \|A\| \leq \sqrt{s} \|A\|_1. \quad (1.3)$$

- The set of all functions $w : \mathbb{R}_{\geq 0} \rightarrow \mathbb{R}^q$ endowed with the (essential) supremum norm $\|w\|_\infty = (\text{ess}) \sup_{t \geq 0} \|w(t)\| < \infty$, is denoted by L_∞^q

1.4.2 Definitions and Mathematical Tools

Definition 1 *Class \mathcal{K} Function* [Khalil02] A continuous function $\gamma : [0, a) \rightarrow [0, \infty)$ belongs to class \mathcal{K} if it is strictly increasing and $\gamma(0) = 0$. It belongs to class \mathcal{K}_∞ if $a = \infty$ and $\gamma(\tau) \rightarrow \infty$ as $r \rightarrow \infty$.

Definition 2 *Class \mathcal{KL} Function* [Khalil02] A continuous function $\beta : [0, a) \times [0, \infty) \rightarrow [0, \infty)$ belongs to class \mathcal{KL} if, for each fixed s , the mapping $\beta(\tau, s)$ belongs to class \mathcal{K} with respect to r and, for each fixed r , $\beta(\tau, s)$ is decreasing with respect to s , and $\beta(\tau, s) \rightarrow 0$ as $s \rightarrow \infty$.

Definition 3 Relative Degree [Isidori95] *The single-input single-output nonlinear system*

$$\begin{aligned}\dot{x} &= f(x) + g(x)u \\ y &= h(x)\end{aligned}$$

is said to have relative degree r at a point x^0 if

- $L_g L_f^k h(x) = 0$ for all x in a neighborhood of x^0 and all $k < r - 1$
- $L_g L_f^{r-1} h(x^0) \neq 0$

Definition 4 Zero Dynamics [Isidori95] *The dynamics describing the internal behavior of a system when input and initial conditions have been chosen in such a way as to constrain the output to remain identically zero.*

Definition 5 Input-to-State Stability [Sontag95] *A system*

$$\dot{x} = f(x, v), \tag{1.4}$$

where f is continuously differentiable, it holds that $f(0, 0) = 0$, x represents the states, and v represents all the external inputs of the system, including perturbations, command signals, and noises, is said to be input-to-state stable if there exists a function $\beta \in \mathcal{KL}$ and a function $\gamma \in \mathcal{K}$ such that for any initial state $x(t_0)$, and any bounded input $v(t)$, the solution $x(t)$ satisfies

$$|x(t)| \leq \beta(|x(t_0)|, t - t_0) + \gamma \left(\sup_{t_0 \leq T \leq t} |v(T)| \right). \tag{1.5}$$

Definition 6 ISS Lyapunov Function [Jiang96] *For (1.4), a smooth function V is said to be an ISS-Lyapunov function if V is proper, positive definite, i.e., there exists functions $\psi_1, \psi_2 \in \mathcal{K}_\infty$ such that*

$$\psi_1(|x|) \leq V(x) \leq \psi_2(|x|),$$

and there exist functions $a \in \mathcal{K}_\infty$ and $\theta \in \mathcal{K}$ such that

$$\nabla V(x)f(x, u) \leq -a(V(x)) + \theta(|v|).$$

Lemma 1 Young's Inequality *From Young's inequality it can be proved that if b and c are non negative real numbers, then*

$$bc \leq \frac{b^2}{2}\alpha^2 + \frac{c^2}{2}\alpha^{-2},$$

for any $\alpha > 0$.

Theorem 1 ISS Properties [Sontag95] *The following properties are equivalent for system (1.4)*

1. *It is ISS.*
2. *It admits an ISS-Lyapunov function.*
3. *There exist a \mathcal{KL} function β , and a \mathcal{K} function γ such that (1.5) holds.*

Theorem 2 Lyapunov Non-Linear Small Gain Theorem [Jiang96] *If, for interconnected systems*

$$\dot{x}_1 = f_1(x_1, x_2, v_1) \tag{1.6}$$

$$\dot{x}_2 = f_2(x_1, x_2, v_2), \tag{1.7}$$

there exist an ISS-Lyapunov function V_i , for the x_i subsystem, $i = \{1, 2\}$, such that with functions $\phi_i \in \mathcal{K}_\infty$, $\chi_i, \gamma_i \in \mathcal{K}$ the following holds:

$$V_i(x_i) \geq \max\{\chi_i(V_j(x_j)), \gamma_i(\|v_i\|)\} \Rightarrow$$

$$\nabla V_i(x_i)f_i(x_i, x_j, v_i) \leq -\phi_i(V_i),$$

with $j = \{2, 1\}$, and

$$\chi_1(\tau) \circ \chi_2(\tau) < \tau \quad \forall \tau > 0, \tag{1.8}$$

then the interconnected system (1.6), (1.7) is ISS and the zero solution of (1.6), (1.7), with $u = 0$, is globally asymptotically stable.

Corollary 1 [Jiang96] *If V_i are ISS-Lyapunov functions for (1.6), (1.7), and*

$$\nabla V_i(x_i) f_i(x_i, x_j, v_i) \leq -a_i(V_i(x_i)) + \theta_i^x(V_j(x_j)) + \theta_i^v(\|v_i\|),$$

with

$$\theta_i^x(\tau) = \kappa_i a_j(\tau),$$

for some $\kappa_i > 0$, then the condition (1.8) is satisfied if $\kappa_1 \kappa_2 < 1$.

Chapter 2

Sliding Surface Design

After the appearance of the first descriptions of a *sliding* phenomenon occurring in some systems, the interest of the control community arose around the possibilities of exploiting this property in a convenient way, or even forcing it in order to obtain a desired behavior on system's trajectories. With this, the opportunity to force the solutions of a system to slide exactly on a desired trajectory or surface was introduced, and this is the basis of what we know today as sliding-mode control. This surface must be designed according to the needs of the specific application. The present section will be devoted to the design of precisely this surface for the case of (1.2), such that the zero dynamics are stabilized and the trajectories are drawn to the origin. To this end, firstly a special Normal Form, referred to as output normal form will be introduced. This form is a generalization of the one that appeared in [Castaños11], and separates the system's zero dynamics, if there are any, from the rest of the state. Afterwards, a methodology for stabilizing this part of the dynamics, through a virtual controller will be developed, and finally the surface will be designed, such that when it is forced to zero, the virtual controller will be guaranteed to act as designed.

2.1 Output Normal Form

The employment of state transformations, in order to represent system states in a particular form has been exploited throughout the history of system's theory. Two of these forms are widely known, and classical to the control theory: the classical regular form [Utkin92], which facilitates the design of the sliding surface, and the Normal Form [Isidori95], which allows to clearly visualize the zero dynamics of a system. The following proposition will introduce a transformation that brings the coordinates of an arbitrary linear system to its Normal Form:

Proposition 1 *Consider system (1.2), with relative degree r and dimension n . From the definition of relative degree it is known that $CA^{i-1}B = 0, 1 \leq i < r$, and $CA^{r-1}B \neq 0$. Also, since $B \neq 0$, there exists a matrix $B^\perp \in \mathbb{R}^{m \times n}$ with m linearly independent rows such that $B^\perp B = 0$. If y is a noiseless output, one can take it, along with its first successive $(r-1)$ derivatives as a set of coordinates z_1, \dots, z_r to construct a coordinate transformation with invertible T that brings the system to the normal form introduced in [Isidori95]. This transformation is*

$$\begin{bmatrix} \bar{\xi} \\ \bar{z} \end{bmatrix} = T_1 x,$$

with

$$T_1 = \begin{bmatrix} B_1^\perp \\ \vdots \\ B_m^\perp \\ \hline C \\ \vdots \\ CA^{r-1} \end{bmatrix},$$

where $m = n - r$. The system, in the new coordinates, is

$$\begin{aligned}
 \dot{\bar{\xi}} &= \bar{A}_\xi \bar{\xi} + \bar{E}_\xi \bar{z} \\
 \dot{\bar{z}}_1 &= \bar{z}_2 \\
 &\vdots \\
 \dot{\bar{z}}_{r-1} &= \bar{z}_r \\
 \dot{\bar{z}}_r &= \bar{E}_z \bar{\xi} + \bar{A}_z \bar{z} + \bar{u} \\
 \bar{y} &= \bar{z}_1,
 \end{aligned} \tag{2.1}$$

with $\bar{\xi} \in \mathbb{R}^m$, $\bar{z}_1, \dots, \bar{z}_r \in \mathbb{R}$, and $\bar{u} = \bar{b}_z v$.

Remark 1 *If the complete substate \bar{z} is taken exactly to zero, then the $\bar{\xi}$ -subsystem becomes $\dot{\bar{\xi}} = \bar{A}_\xi \bar{\xi}$ which, according to definition 4, represents the zero dynamics of the system.*

In chapter 14 of [Khalil02], a special case of the normal form is briefly mentioned. In this special case the $\dot{\bar{\xi}}$ -equation depends on variables $\bar{\xi}$ and \bar{z}_1 only, instead of $\bar{\xi}$, $\bar{z}_1, \bar{z}_2, \dots, \bar{z}_r$ as is in (2.1). This special form will be referred to, in the following, as the output normal form (ONF). The ONF inherits some properties of the aforementioned cases in the sense that it separates the system dynamics in two: the part that represents the zero dynamics and the rest, and can be written as

$$\dot{\xi} = A_\xi \xi + E_{\xi 1} z_1 \tag{2.2}$$

$$\dot{z}_1 = z_2 \tag{2.3}$$

$$\vdots$$

$$\dot{z}_{r-1} = z_r$$

$$\dot{z}_r = A_z z + E_z \xi + u$$

$$y = z_1,$$

with $\xi \in \mathbb{R}^m$, and $z_1, \dots, z_r \in \mathbb{R}$, and $u = b_z v$, and is illustrated in a block diagram in Figure 2.1. It is easy to observe that the difference between (2.1) and (2.2)-(2.3) is that in

the ONF the zero dynamics, represented by ξ , is driven by the output z_1 only, instead of the output itself and its derivatives. This slight variation makes a difference in the design of the control for the zero dynamics: in the latter, depending on the matrix's characteristics, there exists the possibility of controlling ξ through the output only and, in the former, ξ should be controlled through the output and its first $r - 1$ derivatives.

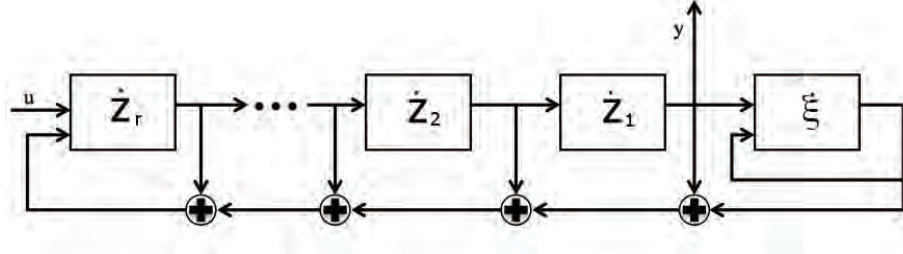

Figure 2.1: Output Normal Form.

The following proposition introduces a transformation that takes a system of arbitrary order, in the Normal Form, to its ONF:

Proposition 2 *A coordinate transformation with invertible T that brings a linear system (2.1), to the form (2.2)-(2.3) is*

$$\begin{bmatrix} \xi \\ z \end{bmatrix} = T \begin{bmatrix} \bar{\xi} \\ \bar{z} \end{bmatrix}$$

with

$$T = \begin{bmatrix} I_m & - \begin{bmatrix} \bar{E}_{\xi 2} & \cdots & \bar{E}_{\xi r} & 0_{m \times 1} \end{bmatrix} \\ 0_{r \times m} & I_r \end{bmatrix}$$

and $\bar{E}_{\xi} = \begin{bmatrix} \bar{E}_{\xi 1} & \cdots & \bar{E}_{\xi r} \end{bmatrix}$, where each $\bar{E}_{\xi i} \in \mathbb{R}^{m \times 1}$, $i = 1, \dots, r$.

Using the results of Propositions 1 and 2, a general transformation that, without loss of generality, takes any linear system of arbitrary order to the ONF, can be established:

Lemma 2 *A linear system (1.2) can be represented in an ONF without loss of generality, through a coordinate transformation*

$$\begin{bmatrix} \xi \\ z \end{bmatrix} = Tx$$

if the invertible matrix T is defined as

$$T = T_2 T_1$$

where T_1 and T_2 are as defined in Propositions 1 and 2 respectively.

2.2 Reduced Order System

Once that the system's state coordinates have been separated into the zero dynamics and the rest of the variables, it is possible to analyze each of these parts individually. A classical preoccupation when using block forms is how to deal with an unstable zero dynamics. The controllability proof for the pairs (A_ξ, E_ξ) of (2.1) that appears in [Utkin92] is a well known result that brings some light on how to design a virtual controller for this part. This section focuses precisely on this issue, for subsystem (2.2) with unmeasurable state, providing a controllability proof for the pair $(A_\xi, E_{\xi 1})$. Since this work deals with systems of which only output information is available, observability is also an issue to be taken into account. For this, it is shown how to construct not only a controllable, but an observable reduced order system, composed of the unmeasurable state ξ , and a virtual output which will also be defined, using the following Lemma.

Lemma 3 *If the pair (A, B) of (1.1) is controllable, and the pair (A, C) of (1.1) is observable, then $(A_\xi, E_{\xi 1})$ is controllable and (A_ξ, E_z) is observable.*

Proof Recall that system (1.1) is controllable iff

$$\text{rank} \begin{bmatrix} \lambda I - A & B \end{bmatrix} = n,$$

for all $\lambda \in \mathbb{C}$, and observable iff

$$\text{rank} \begin{bmatrix} \lambda I - A \\ C \end{bmatrix} = n,$$

for all $\lambda \in \mathbb{C}$ [Chen98]. In the coordinates of the ONF (2.2)-(2.3), this can be written as

$$\text{rank} \left(\lambda I_n - \begin{bmatrix} A_\xi & E_{\xi 1} & 0_{m \times (r-1)} & 0_{m \times 1} \\ 0_{(r-1) \times m} & 0_{(r-1) \times 1} & I_{(r-1)} & 0_{(r-1) \times 1} \\ E_z & a_{z1} & A_{zr} & 1 \end{bmatrix} \right) = n$$

where $\begin{bmatrix} a_{z1} & A_{zr} \end{bmatrix} = A_z$ with $A_{zr} \in \mathbb{R}^{1 \times (r-1)}$.

Note that the last column is composed of zeros except for the last element. This makes the last row linearly independent of the rest, so it can be discarded from the analysis, along with the remaining zero elements. This yields

$$\text{rank} \left(\lambda I_{(n-1)} - \begin{bmatrix} A_\xi & E_{\xi 1} & 0_{m \times (r-1)} \\ 0_{(r-1) \times m} & 0_{(r-1) \times 1} & I_{(r-1)} \end{bmatrix} \right) = n - 1.$$

The same happens with the last $r - 1$ rows and columns of the above matrix, so the rank condition becomes

$$\text{rank} \begin{bmatrix} \lambda I_m - A_\xi & -E_{\xi 1} \end{bmatrix} = m.$$

A similar procedure can be carried out for the observability matrix:

$$\text{rank} \left(\lambda I_n - \begin{bmatrix} A_\xi & E_{\xi 1} & 0_{m \times (r-1)} \\ 0_{(r-1) \times m} & 0_{(r-1) \times 1} & I_{(r-1)} \\ E_z & a_{z1} & A_{zr} \\ 0_{1 \times m} & 1 & 0_{1 \times (r-1)} \end{bmatrix} \right) = n,$$

so, analogously, the rank condition becomes

$$\text{rank} \begin{bmatrix} \lambda I_m - A_\xi \\ -E_z \end{bmatrix} = m,$$

To relate the observability of the pair (A_ξ, E_z) , with subsystem (2.2), it is necessary to recover the term $E_z\xi$. If y is a noiseless output, one can take its derivatives until the r^{th} order¹, and define a virtual output as

$$y_v := y^{(r)} - A_z \begin{bmatrix} y & \dots & y^{(r-1)} \end{bmatrix}^\top - u.$$

From the result of Lemma 3 one can define a virtual control signal for (2.2) as

$$u_v = z_1$$

so, along with y_v , the following observable and controllable reduced order system can be constructed²:

$$\begin{aligned} \dot{\xi} &= A_\xi \xi + E_{\xi 1} u_v \\ y_v &= E_z \xi. \end{aligned} \tag{2.4}$$

2.3 Virtual Control Design

In the previous section the controllability of the zero dynamics through the output of the system (1.1) was proven, as well as the observability property of (2.2) with y_v . It is natural to use this result to design a virtual control for the dynamics of (2.2) through z_1 , and to also construct an observer for the unmeasurable state ξ using y_v . The dynamics of this observer will be represented by the variable $\eta \in \mathbb{R}^{n-r}$ and have the form

¹In the last few lines, as well as in the past section and other parts of this document it is assumed that r derivatives of the output y , i.e. the variables z_1, \dots, z_r , can be obtained (in this case, in order to construct the virtual output y_v). It is not the goal of this work to explore differentiation techniques but, in order to obtain the necessary estimates, various methods can be implemented. For example, the robust exact differentiator of [Levant98] if a known bound of the $(r+1)$ th derivative of y is available, the modification that provides uniformity with respect to the initial conditions of [Angulo13], or the recent result of [Oliveira15] which presents a global exact differentiator based on higher-order sliding modes and dynamic gains, among others.

²This reduced order system is realizable if the output y is differentiable $r-1$ times. This is always satisfied for the case of a linear system with a noiseless output, such as (1.1).

$$\begin{aligned}\dot{\eta} &:= A_\eta \eta - B_\eta y_v \\ &= A_\eta \eta + E_\eta \xi,\end{aligned}\tag{2.5}$$

where $E_\eta = -B_\eta E_z$. The parameters $A_\eta \in \mathbb{R}^{(n-r) \times (n-r)}$, and $B_\eta \in \mathbb{R}^{(n-r) \times 1}$ are free to be chosen appropriately. A procedure to do so will be shown later.

The virtual control signal for system (2.4) will be driven by the dynamics of η , and is defined as $u_v = K_v \eta$, with $K_v \in \mathbb{R}^{1 \times (n-r)}$ as design parameter, or gain. Naturally, z_1 (the measured output) is used as a virtual control for ξ , so a scalar signal $\phi_1 = \phi_1(y, \eta)$ is constructed as

$$\phi_1 = z_1 - K_v \eta.\tag{2.6}$$

Substituting (2.6) in (2.2) one obtains the closed loop

$$\begin{aligned}\dot{\xi} &= A_\xi \xi + B_\xi \eta + E_{\xi 1} \phi_1 \\ \dot{\eta} &= A_\eta \eta + E_\eta \xi \\ \phi_1 &= y - K_v \eta,\end{aligned}\tag{2.7}$$

where $B_\xi = E_{\xi 1} K_v$.

Remark 2 *The value of the constants B_ξ , E_η and A_η of (2.7) are determined when the dynamics of η , and the gain K_v of the virtual control are designed. These parameters should be selected such that the system (2.7) is globally asymptotically stable when $\|\phi_1\| = 0$.*

An alternative way of constructing η is through an auxiliary dynamic variable β defined as

$$\dot{\beta} = A_\eta (\beta - B_\eta y^{(r-1)}) + B_\eta \left(A_z \begin{bmatrix} y & \dots & y^{(r-1)} \end{bmatrix}^\top + u \right),$$

and defining η as

$$\eta := \beta - B_\eta y^{(r-1)}.$$

Then, the dynamics of η will recover the observer-like form (2.5). This alternative offers the advantage that the output y must be differentiated $r - 1$ times which, instead of r times which, for some applications, might be convenient.

2.4 Relative Degree r Sliding Surface

Recall system (2.7). In the previous section it was mentioned that the parameters B_ξ , A_η and E_η should be designed such that the closed loop is globally asymptotically stable when ϕ_1 is zero. This variable represents the difference between the measured signal y , and the designed $K_v\eta$. When it is equal to zero it necessarily follows that the virtual control is acting as designed on the zero dynamics. This variable can then be considered an error measurement. The control objective, in order to control the zero dynamics ξ , turns into forcing ϕ_1 to zero, making it a suitable choice for sliding variable. Note that ϕ_1 depends on y and η so, clearly, it has relative degree r .

Defining the first r successive derivatives of signal (2.6) as a set of coordinates as

$$\begin{aligned}\sigma_1 &:= \phi_1 \\ \sigma_2 &:= \dot{\sigma}_1 = \dot{\phi}_1 \\ &\vdots \\ \sigma_r &= \dot{\sigma}_{r-1},\end{aligned}$$

it follows that $\dot{\sigma}_r = \phi_1^{(r)}$ and the following dynamics are obtained:

$$\begin{aligned}\dot{\sigma}_1 &= \sigma_2 \\ \dot{\sigma}_2 &= \sigma_3 \\ &\vdots \\ \dot{\sigma}_r &= \Gamma_{\sigma 1}\sigma + \Gamma_{\sigma 2}\xi + \Gamma_{\sigma 3}\eta + u,\end{aligned}\tag{2.8}$$

where $\Gamma_{\sigma 1} \in \mathbb{R}^{1 \times r}$, $\Gamma_{\sigma 2}, \Gamma_{\sigma 3} \in \mathbb{R}^{1 \times m}$ are known combinations of the parameters of (2.3) and (2.7). The following Lemma can be established:

Lemma 4 *Consider the variable*

$$\sigma = y - K_v \eta$$

where $\dot{\eta} = A_\eta \eta + B_\eta \left(y^{(r)} - A_z \begin{bmatrix} y & \dot{y} & \dots & y^{(r-1)} \end{bmatrix}^\top - u \right)$. If σ and its first r successive time derivatives are forced to zero through a signal u , then the trajectories of (2.7) will globally converge to the origin, provided that the parameters K_v , A_η , and B_η are chosen adequately.

From Lemma 4, σ is a sliding variable for (2.7), and the closed loop of this system, with the dynamics of (2.8), can be written as

$$\begin{aligned}\dot{\xi} &= A_\xi \xi + B_\xi \eta + E_{\xi 1} \sigma_1 \\ \dot{\eta} &= A_\eta \eta + E_\eta \xi \\ \dot{\sigma} &= A_\sigma \sigma + E_{\sigma 1} \xi + E_{\sigma 2} \eta + B_\sigma u,\end{aligned}\tag{2.9}$$

$$A_\sigma = \begin{bmatrix} 0_{(r-1) \times 1} & I_{(r-1)} \\ & \Gamma_{\sigma 1} \end{bmatrix}, \quad E_\sigma = \begin{bmatrix} \Gamma_{\sigma 2} & \Gamma_{\sigma 3} \end{bmatrix}, \quad B_\sigma = \begin{bmatrix} 0_{(r-1) \times 1} \\ 1 \end{bmatrix},$$

with $B_\xi = E_\xi K_v$.

Note that the dynamics of σ are governed by a chain of integrators, and a linear combination of ξ and η in the last equation. Each of the lines in (2.9) can be considered a subsystem that is interconnected to the rest. Thus, a control law u that not only brings σ to zero, but that also maintains the stability of the rest of the interconnection is needed.

2.5 Relative Degree One Sliding Surface

A relative degree r sliding variable was defined in the past section, however, it is sometimes convenient to reduce the order of the controller, due to actuator limitations, tuning difficulties, or to reduce the complexity of the algorithm. A relative degree one sliding variable will be defined in the following Lemma, using the output y and its first $r - 1$ successive derivatives, which coincide with those that should be obtained in order to construct the auxiliary η as is shown below.

Lemma 5 *Consider the variable*

$$\sigma = y^{(r-1)} - c_{r-1} y^{(r-2)} - \dots - c_2 \dot{y} - c_1 (y - K_v \eta),$$

where c_1, \dots, c_{r-1} are some constants, and recall that $\dot{\eta} = A_\eta \eta + B_\eta \left(y^{(r)} - A_z \begin{bmatrix} y & \dot{y} & \dots & y^{(r-1)} \end{bmatrix}^\top - u \right)$. If σ and its first time-derivative are forced to zero through a signal u , then the trajectories of (2.7) will globally converge to the origin, provided that the parameters c_i , K_v , A_η , and B_η , for $i = 1, 2, \dots, r - 1$ are chosen adequately.

Proof If $\sigma = 0$, it follows that

$$y^{(r-1)} = c_{r-1} y^{(r-2)} + \dots + c_2 \dot{y} + c_1 (y - K_v \eta).$$

Now, consider the new set of coordinates $\phi_1, \phi_2, \dots, \phi_{r-1}, \sigma \in \mathbb{R}$

$$\begin{aligned}
\phi_1 &:= y - K_v \eta = z_1 - K_v \eta \\
\phi_2 &:= \dot{y} = z_2 \\
\phi_3 &:= \ddot{y} = z_3 \\
&\vdots \\
\phi_{r-1} &:= y^{(r-2)} = z_{r-1},
\end{aligned} \tag{2.10}$$

where ϕ_1 is exactly as defined in the previous section. Then, the dynamics of (2.10) have the form

$$\begin{aligned}
\dot{\phi}_1 &= \phi_2 - E_\eta K_v \xi - A_\eta K_v \eta \\
\dot{\phi}_2 &= \phi_3 \\
&\vdots \\
\dot{\phi}_{r-2} &= \phi_{r-1} \\
\dot{\phi}_{r-1} &= c_1 \phi_1 + c_2 \phi_2 + \cdots + c_{r-1} \phi_{r-1}.
\end{aligned}$$

Suppose now that ξ and η are equal to zero. Then, the above system is in the controller canonical form, and an adequate choice of c_i would lead to taking all of ϕ_i to zero. When $\phi_1 = 0$, it necessarily follows that the virtual control defined in Section 2.3 is acting on (2.7) as designed.

The dynamics of (2.10), along with those of (2.7) and σ , yield

$$\begin{aligned}
\dot{\xi} &= A_\xi \xi + B_\xi \eta + E_{\xi 1} \phi_1 \\
\dot{\eta} &= A_\eta \eta + E_\eta \xi \\
\dot{\phi} &= A_\phi \phi + E_{\phi 1} \xi + E_{\phi 2} \eta + F_\phi \sigma \\
\dot{\sigma} &= A_\sigma \sigma + E_{\sigma 1} \xi + E_{\sigma 2} \eta + F_\sigma \phi + u,
\end{aligned} \tag{2.11}$$

where

$$A_\phi = \begin{bmatrix} 0_{(r-2) \times 1} & I_{(r-2)} \\ -c_1 & [-c_2 \quad \dots \quad -c_{r-1}] \end{bmatrix}, \quad E_{\phi 1} = \begin{bmatrix} -E_\eta K_v \\ 0_{(r-2) \times m} \end{bmatrix},$$

$$E_{\phi 2} = \begin{bmatrix} -A_\eta K_v \\ 0_{(r-2) \times m} \end{bmatrix}, \quad F_\phi = \begin{bmatrix} 0_{(r-2) \times 1} \\ 1 \end{bmatrix},$$

with A_σ , $E_{\sigma 1}$, $E_{\sigma 2}$ and F_σ being known combinations of the parameters of (2.3) and (2.7), and $B_\xi = E_\xi K_v$.

Again, each of these variables can be seen as interconnected subsystems. Thus, as was the case in the previous section, a control law u that not only brings σ to zero, but also maintains the stability of the complete interconnection is needed.

Chapter 3

Perturbations and External Inputs

In the previous chapters the case of (1.2) was considered, i.e., when there are no external inputs or perturbations. In this section we will revisit system (1.1), i.e.

$$\begin{aligned}\dot{x} &= Ax + Bv + Dw \\ y &= Cx,\end{aligned}$$

where w is a vector of dimension q and contains all the unknown inputs of the system, and describe the perturbations admitted by this methodology. These perturbations are assumed to satisfy the following assumption:

Assumption 1 *The perturbation term is uniformly bounded, i.e. $\|w\| \leq \bar{w}$, for a $\bar{w} < \infty$.*

This is a standard assumption in the sliding-mode theory, but the knowledge of the value of the upper bound \bar{w} is not necessarily required for this work, as opposed to what is classically the case.

Three cases of the type of perturbations admitted will be considered: The first one is mentioned only for completeness because it represents the unperturbed case, that is, when $w = 0$, which matches the description of the system made in the previous sections.

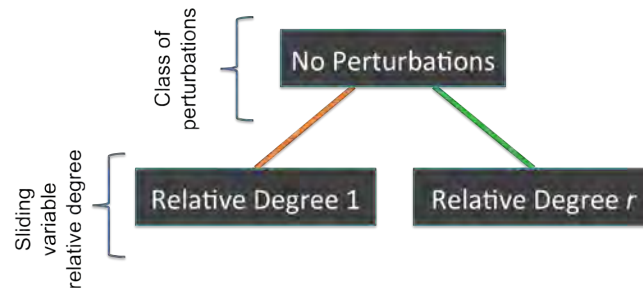

Figure 3.1: Design choices of the unperturbed case.

The remaining two include perturbations that satisfy either a *relative degree condition*, or a *Lispchitz condition*. For each of these two cases, the way in which the perturbations affect the system, and the form that the equations take for the choices of relative degree for the sliding variable will be examined.

3.1 Unperturbed case

In this case it is considered that there are no perturbations or external inputs, i.e. $w = 0$. This is the case that has been considered up until now in this document. Any choice of the relative degree of the sliding variable can be chosen (1 or r), as is illustrated in Figure 3.1.

3.2 Relative Degree Condition

Definition 3 states how to calculate the relative degree of a system, i.e. of its output with respect to its input u . In this same way the relative degree of the output of (1.1) with respect to any another input signal can be determined. In particular, it is of interest for this section the relative degree of y with respect to the perturbation w . This value will be denoted by r_w , and will be instrumental to set the following condition:

Assumption 2 *The relative degree r_w of the output with respect to the disturbance w , and the relative degree r of the output with respect to the input u satisfy the inequality*

$$r < r_w \leq n$$

The outermost part of the above inequality, i.e. $r < n$, indicates that system (1.1) has a zero dynamics, i.e. some internal dynamics that are present when the output y and its r successive derivatives are equal to zero. For the left part, recall that from the definition of relative degree we have that $CA^{i-1}D = 0$, $1 \leq i < r_w$ and $CA^{r_w-1}D \neq 0$. Then, from the transformation introduced in Proposition 1, it is evident that, since $r_w > r$, no perturbations will appear in the states z_1 through z_r , and they will only be matched to the control input and present in the zero dynamics. The consequence of the above conditions is better appreciated when the system is expressed in its ONF, which is

$$\begin{aligned} \dot{\xi} &= A_\xi \xi + E_{\xi 1} z_1 + D_\xi w_\xi \\ \dot{z}_1 &= z_2 \\ &\vdots \\ \dot{z}_{r-1} &= z_r \\ \dot{z}_r &= A_z z + E_z \xi + u + D_z w_z \\ y &= z_1, \end{aligned} \tag{3.1}$$

where ξ is the zero dynamics, $w_\xi \in \mathbb{R}^{q_\xi}$ is the unmatched perturbation term, $w_z \in \mathbb{R}^{q_z}$ is the matched perturbation, and $q_\xi + q_z = q$.

Recall from section 2.2 that the virtual output of the reduced order system is $y_v := y^{(r)} - A_z \begin{bmatrix} y & \dots & y^{(r-1)} \end{bmatrix}^\top - u$, and from section 2.3, that the observer uses y_v as an input. The virtual output y_v contains the r th derivative of y , which by the Assumption 2,

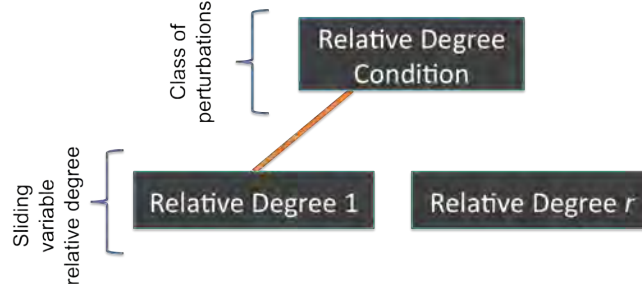

Figure 3.2: Design choices of the case when the perturbations satisfy the relative degree condition 2.

yields

$$\begin{aligned}\dot{\xi} &= A_{\xi}\xi + E_{\xi 1}u_v + w_{\xi} \\ y_v &= E_z\xi + D_zw_z.\end{aligned}\quad (3.2)$$

The closed loop (2.7), for the perturbed system can be written as

$$\begin{aligned}\dot{\xi} &= A_{\xi}\xi + B_{\xi}\eta + E_{\xi 1}\phi_1 + D_{\xi}w_{\xi} \\ \dot{\eta} &= A_{\eta}\eta + E_{\eta}\xi + D_zw_z \\ \phi_1 &= y - K_v\eta.\end{aligned}\quad (3.3)$$

In this perturbed case it is recommended to follow the methodology to obtain a relative degree one sliding surface, and implement a first order sliding-mode controller that forces it to zero, as is illustrated in Figure 3.2.

In this case, the augmented system (2.11) has the form

$$\begin{aligned}\dot{\xi} &= A_{\xi}\xi + B_{\xi}\eta + E_{\xi 1}\phi_1 + D_{\xi}w_{\xi} \\ \dot{\eta} &= A_{\eta}\eta + E_{\eta}\xi + D_zw_z \\ \dot{\phi} &= A_{\phi}\phi + E_{\phi 1}\xi + E_{\phi 2}\eta + F_{\phi}\sigma \\ \dot{\sigma} &= A_{\sigma}\sigma + E_{\sigma 1}\xi + E_{\sigma 2}\eta + F_{\sigma}\phi + D_{\sigma}w_{\sigma} + u.\end{aligned}\quad (3.4)$$

Note that the complete vector ϕ is free of unknown inputs.

The recommendation above comes from the fact that the variable ϕ_1 depends on the output y , and η , both of which dynamics are affected by the matched perturbation. If a higher relative degree surface is desired, then it would be necessary to impose a differentiability condition on the perturbations, in addition to Assumption 2, because it would be necessary to differentiate y several times. This condition will be stated in the next subsection.

3.3 Lipschitz condition

The Assumption 2 of the last subsection focuses on how the perturbations enter the system (1.1). If this condition is not satisfied, then the perturbation can affect any part of the state variables (or even come in the form of measurement noise)¹. In this case, the system in the ONF takes the form

$$\begin{aligned}
 \dot{\xi} &= A_\xi \xi + E_{\xi 1} z_1 + D_\xi w_\xi & (3.5) \\
 \dot{z}_1 &= z_2 + w_{z1} \\
 &\vdots \\
 \dot{z}_{r-1} &= z_r + w_{zr-1} \\
 \dot{z}_r &= A_z z + E_z \xi + D_z w_z + u \\
 y &= z_1.
 \end{aligned}$$

¹In Section 1.2 it was mentioned that the case of noiseless outputs would be considered in this work, however, under some conditions of this noise, the case where it exists could also be admitted. This case will not be represented in the equations, but the conditions that should be satisfied by the noise will be stated.

From the definition of the virtual output y_v it can be seen that r derivatives of the output are necessary for its construction. From (3.5) we have that

$$\begin{aligned}\dot{y} &= \dot{z}_1 = z_2 + D_1 w_{z1} \\ \ddot{y} &= \dot{z}_2 + \dot{w}_{z1} = z_3 + w_{z2} + \dot{w}_{z1} \\ &\vdots \\ y^{(r-1)} &= z_r + w_{zr-1} + \dot{w}_{zr-2} + \cdots + w_{z1}^{(r-2)} \\ y^{(r)} &= A_z z + E_z \xi + w_z + \dot{w}_{zr-1} + \cdots + w_{z1}^{(r-1)} + u,\end{aligned}$$

where each $w_{zi} \geq 0$, $i = 1, 2, \dots, r$. Then, the virtual output y_v is given by

$$y_v = E_z \xi + D_v w_v$$

where w_v is a combination of the perturbations w_{zi} and their (up to) $r - 1$ derivatives². Since the perturbation may be present in any channel of the state space, then it is required for it to satisfy a differentiability condition, which is stated as follows:

Assumption 3 *The unknown input w is at least C^{r-1} and its $r - 2$ nd derivative is Lipschitz.*

Remark 3 *In the case that the output y presents some measurement noise, this noise should also satisfy the following differentiability condition: The measurement noise is at least C^r and its $r - 1$ st derivative is Lipschitz.*

The closed loop of (2.7) is, in this case:

$$\begin{aligned}\dot{\xi} &= A_\xi \xi + B_\xi \eta + E_{\xi 1} \phi_1 + D_\xi w_\xi \\ \dot{\eta} &= A_\eta \eta + E_\eta \xi + D_v w_v \\ \phi_1 &= y - K_v \eta.\end{aligned}\tag{3.6}$$

²If the output y includes some noise, the term w_v would also include this noise, and its first r derivatives.

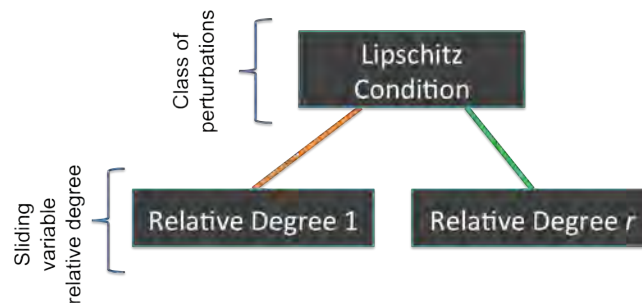

Figure 3.3: Design choices of the case when the perturbations satisfy the Lipschitz condition 3.

For (3.6) either a relative degree one, or a r relative degree sliding surface can be chosen, depending on the designer's preference, or the application's requirements, as is illustrated in Figure 3.3

If an r order sliding variable is defined, as in section 2.4, then the closed loop (2.9) has the form

$$\begin{aligned}
 \dot{\xi} &= A_{\xi}\xi + B_{\xi}\eta + E_{\xi 1}\sigma_1 + D_{\xi}w_{\xi} \\
 \dot{\eta} &= A_{\eta}\eta + E_{\eta}\xi + D_{\eta}w_{\eta} \\
 \dot{\sigma} &= A_{\sigma}\sigma + E_{\sigma 1}\xi + E_{\sigma 2}\eta + D_{\sigma}w_{\sigma} + B_{\sigma}u,
 \end{aligned} \tag{3.7}$$

where w_{σ} is also a combination of all w_{z_i} and their up to $(r-1)$ derivatives.

On the other hand, for a relative degree one sliding variable, recall the coordinates ϕ of (2.10). In this perturbed case they are:

$$\begin{aligned}
\phi_1 &:= y - K_v \eta = z_1 - K_v \eta \\
\phi_2 &:= \dot{y} = z_2 + w_{z1} \\
\phi_3 &:= \ddot{y} = z_3 + \dot{w}_{z1} + w_{z2} \\
&\vdots \\
\phi_{r-1} &:= y^{(r-1)} = z_{r-1} + w_{z1}^{(zr-2)} + w_{z2}^{(zr-3)} + w_{zr-1}.
\end{aligned} \tag{3.8}$$

$$\tag{3.9}$$

The sliding variable was defined as

$$\sigma = y^{(r)} - c_{r-2} y^{(r-1)} - \dots - c_2 \dot{y} - c_1 (y - K_v \eta).$$

Evidently its dynamics will be affected by a combination of the derivatives of the perturbations, which will be grouped in the variable w_σ , so the perturbed augmented system (2.11) is

$$\begin{aligned}
\dot{\xi} &= A_\xi \xi + B_\xi \eta + E_{\xi 1} \phi_1 + D_\xi w_\xi \\
\dot{\eta} &= A_\eta \eta + E_\eta \xi + D_v w_v \\
\dot{\phi} &= A_\phi \phi + E_{\phi 1} \xi + E_{\phi 2} \eta + F_\phi \sigma + D_\phi w_\phi \\
\dot{\sigma} &= A_\sigma \sigma + E_{\sigma 1} \xi + E_{\sigma 2} \eta + F_\sigma \phi + w_\sigma + u,
\end{aligned} \tag{3.10}$$

3.4 Parameter Choice and Design Tradeoff

In the past sections we have analyzed two different design paths that can be taken when choosing the sliding surface for system (1.1), and also two different types of perturbations admitted by the solution method. The combination of these cases lead to different forms of the system's equations. In this section we will establish a design methodology

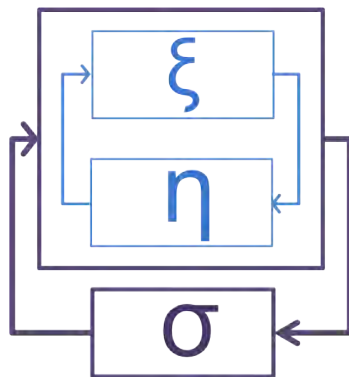

Figure 3.4: Block diagram with relative degree r sliding variable.

for the parameters of the virtual controller and the observer which were defined in section 2.3, and also the parameters of the sliding surface³. In section 2.4 it was mentioned that the closed loop of the sliding surface with the rest of the dynamics can be seen as an interconnection of different subsystems. These interconnections can be represented by the block diagrams of Figure 3.4 (for the case of relative degree r sliding surface), and Figure 3.5 (for a relative degree one sliding variable). In both cases, a feedback loop is present between the subsystems ξ and η . For the case of Figure 3.4 there also exists a feedback loop between $[\xi^\top \ \eta^\top]^\top$, and subsystem σ . In the case of Figure 3.5, $[\xi^\top \ \eta^\top]^\top$ is connected in feedback with ϕ , and then $[\xi^\top \ \eta^\top \ \phi^\top]^\top$, with σ . Thus, it is not enough to design the parameters of each subsystem such that it is stable in its nominal form, and in the presence of each of their respective inputs, but it also should be guaranteed that the stability is not compromised or even destroyed by the interconnections. A useful tool for dealing with this kind of situations is the classical Small-Gain theorem [Khalil02], or its non-linear version, presented in Theorem 2. This result will be used for the design of the

³From the definition of the sliding surface, it can be seen that some parameters must be defined only in the case of a surface of relative degree one, i.e. the constants c_1, \dots, c_{r-1} . From now on, when the parameters of the sliding surfaces are mentioned, it will be making reference to these mentioned constants.

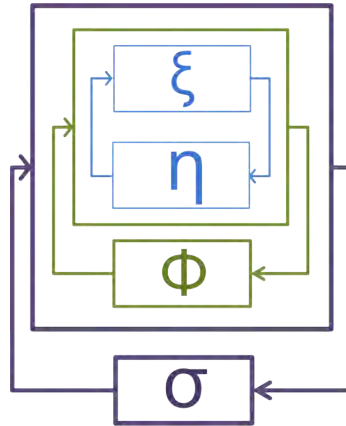

Figure 3.5: Block diagram with relative degree one sliding variable.

parameters and thus, the resulting interconnection will have the ISS property.

Two different options will be presented, from which the designer can choose, depending on the objectives of the application, and the characteristics of the system. The first will be referred to as *priority to the control*, and represents the case when the objective is to keep the control signal relatively small, if the attenuation of the unmatched disturbance is not a priority. The second option will be called *priority to the state*, and should be deployed when it is preferred to guarantee an attenuation of the unmatched perturbations, at the expense of possibly deploying a large control effort. This case is also known as the *cheap control* strategy, which is used when the cost of the control effort is not a problem for the implementation. The recommended combinations of the relative degree choice for the sliding variable, and the design strategy σ are as follows:

- If the perturbation w satisfies the condition 2 (relative degree condition), a sliding surface of relative degree one is recommended to avoid imposing an extra differentiability condition on w . In this case it is up to the designer to choose between giving

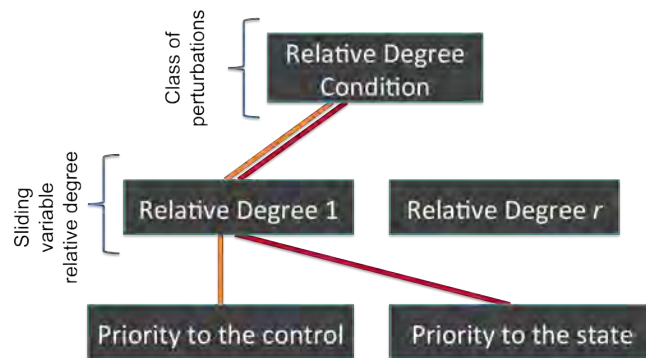

Figure 3.6: Design choices of the case when the perturbations satisfy the relative degree condition 2.

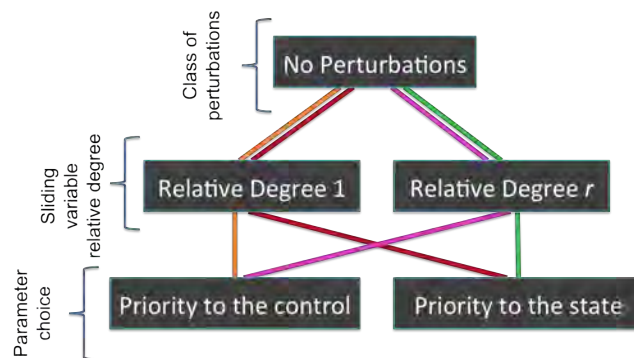

Figure 3.7: Design choices of the unperturbed case.

priority to the control, or to the state (Figure 3.6). This is also the case for the unperturbed case (Figure 3.7).

- If the perturbation w satisfies the condition 3 (Lipschitz condition), then the choice of the relative degree of the sliding surface is free, but it is recommended to follow the *priority to the state* path, since the perturbations may be present in every channel of the state equations (Figure 3.8).

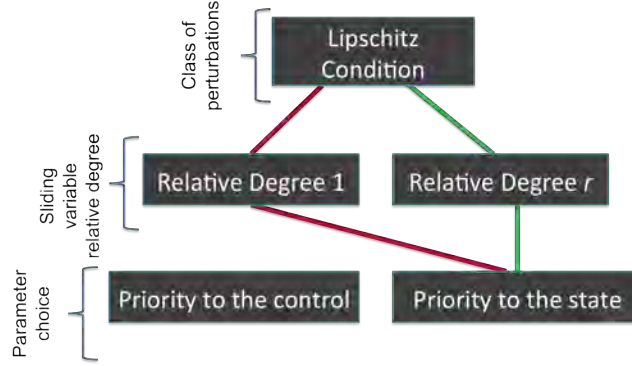

Figure 3.8: Design choices of the case when the perturbations satisfy the Lipschitz condition 3.

3.4.1 Priority to the Control

If it is desired to give priority to the control, that is, to maintain the control signal relatively low, the following procedure should be carried out. First, a new set of coordinates will be defined, depending on whether the sliding surface is of relative degree one or of relative degree r . To this end consider system (3.7), i.e. the perturbed closed loop with a relative degree r sliding surface, and define

$$\Delta := \begin{bmatrix} \xi \\ \eta \end{bmatrix}, \quad A_\Delta := \begin{bmatrix} A_\xi & E_\xi \\ E_\eta & A_\eta \end{bmatrix}, \quad E_\Delta := \begin{bmatrix} E_{\xi 1} \\ \vec{0} \end{bmatrix}, \quad D_\Delta := \begin{bmatrix} w_\xi \\ w_\eta \end{bmatrix}. \quad (3.11)$$

For the case when a relative degree one sliding surface is chosen, the variable Δ and its corresponding matrices are defined as:

$$\Delta := \begin{bmatrix} \xi \\ \eta \\ \phi \end{bmatrix}, \quad A_\Delta := \begin{bmatrix} A_\xi & B_\xi & E_{\xi 1} & \vec{0} \\ E_\eta & A_\eta & \vec{0} & \vec{0} \\ E_{\phi 1} & E_{\phi 2} & F_\phi & A_\phi \end{bmatrix}, \quad E_\Delta := \begin{bmatrix} \vec{0} \\ F_\phi \end{bmatrix}, \quad D_\Delta := \begin{bmatrix} w_\xi \\ w_\eta \\ w_\phi \end{bmatrix}, \quad (3.12)$$

where $w_\phi = 0$ if the perturbations satisfy the relative degree condition of Assumption 2 and $w_\phi \neq 0$ otherwise.

In both cases the following dynamics are obtained:

$$\begin{aligned}\dot{\Delta} &= A_{\Delta}\Delta + E_{\Delta}\sigma + D_{\Delta}w_{\Delta} \\ \dot{\sigma} &= A_{\sigma} + E_{\sigma}\Delta + w_{\sigma}\sigma + u,\end{aligned}$$

where $E_{\sigma} = \begin{bmatrix} E_{\sigma 1} & E_{\sigma 2} \end{bmatrix}$. Note that $\Delta(\Delta, \sigma, w_{\Delta})$ and $\sigma(\sigma, \Delta, w_{\sigma})$ are connected in feedback form.

Recall that the parameters E_{ξ} , E_{η} , A_{η} (and A_{ϕ}) are to be chosen by the designer, and note that $E_{\phi 1}$, $E_{\phi 2}$, and F_{ϕ} will depend on a known combination of their values and those of the system's parameters. The following Lemma can be established:

Lemma 6 *The nominal system $\Delta(\Delta, 0, 0)$, is ISS and therefore globally asymptotically stable (GAS) if the constants E_{ξ} , E_{η} , A_{η} (and A_{ϕ}) are chosen such that*

$$\text{Re}\{\lambda(A_{\Delta})\} < 0.$$

Moreover, its ISS gain with respect to w_{Δ} can be calculated as

$$\gamma_{\Delta} = \frac{2\lambda_{\max}^2(P_{\Delta})\|D_{\Delta}\|}{\lambda_{\min}(P_{\Delta})},$$

where P_{Δ} satisfies $A_{\Delta}P_{\Delta} + P_{\Delta}A_{\Delta}^{\top} < I$.

Remark 4 *The design parameters of A_{Δ} can be chosen in such a way that they not only make the system matrix Hurwitz, but that the value of γ_{Δ} is minimized. This can be achieved by running a numeric minimization method with the gain function γ_{Δ} as the minimization target, and the inequalities $A_{\Delta}P_{\Delta} + P_{\Delta}A_{\Delta}^{\top} < I$ and $\text{re}\{\lambda(A_{\Delta})\} < 0$ as constraints.*

If the conditions of Lemma 6 are satisfied, then system Δ will be robust to the perturbation vector

$$w = \begin{bmatrix} w_{\xi} \\ w_{\eta} \\ w_{\phi} \end{bmatrix},$$

and the ultimate bound for the state can be calculated as

$$|x| \leq \gamma_{\Delta w} \sup |w_{\Delta}|$$

$$\text{where } \gamma_{\Delta w} = \frac{2 \lambda_{max}^2(P_{\Delta}) \|D_{\Delta}\|}{\lambda_{min}(P_{\Delta})}.$$

3.4.2 Priority to the State

This part of the solution focuses on the case when attenuating the unmatched perturbation is a priority, at the expense of possibly needing a large control effort, i.e., when the cost of such an effort is not a problem because the control is *cheap*. To this end, first, the parameters of the virtual controller and the observer (B_{ξ} , A_{η} , E_{η}) should be defined. Recall the form of the controllable and observable reduced order system

$$\dot{\xi} = A_{\xi}\xi + E_{\xi 1}u_v + w_{\xi}$$

$$y_v = E_z\xi + w_{y_v},$$

where w_{y_v} is the perturbation that affects the virtual output in the case of Section 3.2 or that of Section 3.3. Also, from the definition of η it can be seen that it recovers the form of an observer constructed from a noisy output. The problem of determining the gains B_{ξ} , A_{η} , and E_{η} fits exactly into the LQG formulation in which an observer and a control are designed for a perturbed system with a noisy output. This problem can also be solved through an H_{∞} minimization procedure for the case of full information that appears in [Doyle89]. This last method will guarantee an ultimate bound of a transfer function that maps the perturbation and the virtual control along with the state as $\|T_w, [\xi, u_v]\|_{\infty} \leq \gamma_{\infty}$ for a given $\gamma_{\infty} < \infty$.

If a sliding surface of relative degree r has been chosen, then the vector Δ can be defined as

$$\Delta := \begin{bmatrix} \xi \\ \eta \end{bmatrix},$$

and its dynamics will be driven by the matrices defined in (3.11). If a relative degree one sliding surface is deployed, then an intermediate step is needed. To this end, define

$$\Delta_1 := \begin{bmatrix} \xi \\ \eta \end{bmatrix}, \quad A_{\Delta_1} := \begin{bmatrix} A_\xi & B_\xi \\ E_\eta & A_\eta \end{bmatrix}, \quad E_{\Delta_1} := \begin{bmatrix} E_{\xi_1} & \vec{0} \\ \vec{0} & \vec{0} \end{bmatrix},$$

and suppose that $\sigma = 0$ and $w_\xi = w_\eta = w_\phi = 0$ as well. The following dynamics will be obtained

$$\dot{\Delta}_1 = A_{\Delta_1}\Delta_1 + E_{\Delta_1}\phi \quad (3.13)$$

$$\dot{\phi} = A_\phi\phi + E_{\phi_1}\xi + E_{\phi_2}\eta. \quad (3.14)$$

From the above paragraphs it is clear that A_{Δ_1} is already Hurwitz, so it follows that the nominal Δ_1 is GAS. Then, there exists a $P_{\Delta_1} = P_{\Delta_1}^\top > 0$ that satisfies $P_{\Delta_1}A_{\Delta_1} + A_{\Delta_1}^\top P_{\Delta_1} = -Q_{\Delta_1}$ for a $Q_{\Delta_1} > 0$ and, being a linear system, it is easy to calculate its ISS gain with respect to ϕ as

$$\gamma_{\Delta_1} = \frac{2 \lambda_{\max}^2(P_{\Delta_1}) \|E_{\Delta_1}\|}{\lambda_{\min}(P_{\Delta_1})}.$$

Recall that

$$A_\phi = \begin{bmatrix} \vec{0} & I_{r-2} \\ -K_\phi \end{bmatrix}$$

and consider the following linear matrix inequality

$$P_\phi A_\phi + A_\phi^\top P_\phi \leq -Q_\phi$$

where $Q_\phi > 0$. The value of P_ϕ and Q_ϕ and thus the value of their minimum and maximum eigenvalues, will depend on the chosen constants c_1 through c_{r-1} . Now lets us define

$$\Delta := \begin{bmatrix} \xi \\ \eta \\ \phi \end{bmatrix}$$

as in (3.12). This leads to the establishment of the following Lemma

Lemma 7 *The nominal system Δ , i.e. the zero response of the feedback interconnection $\Delta_1 - \phi$, is ISS and therefore GAS if the constants K_ϕ are chosen such that the following inequality holds*

$$\frac{2 \lambda_{max}^2(P_\phi) \|E_{\phi 1}, E_{\phi 2}\|}{\lambda_{min}(P_\phi) \lambda_{min}(Q_\phi)} < \frac{1}{\gamma_{\Delta 1}}.$$

Moreover, its ISS gain with respect to w_Δ can be calculated as

$$\gamma_\Delta = \frac{2 \lambda_{max}^2(P_\Delta) \|D_\Delta\|}{\lambda_{min}(P_\Delta) \lambda_{min}(Q_\Delta)}.$$

where P_Δ , Q_Δ , and E_Δ are defined as in the previous section.

Chapter 4

Sliding Mode Control with ISS Properties

As was mentioned in the introduction one of the most appealing characteristics of the sliding-mode controllers is their capability of forcing an output to converge to the origin exactly, and in finite-time. This makes this kind of controllers a suitable choice for the approach developed in this work, since what is necessary for the solution is to make the designed sliding surface σ equal to zero, in order to guarantee that the virtual control works as expected stabilizing the zero dynamics, and take the trajectories of (1.1) to the origin, in absence of perturbations and to a neighborhood of the origin in presence of matched and/or unmatched perturbations. On the other hand, another popular property of the SMC is the possibility of rejecting matched perturbations, but a major downside is that this robustness is severely compromised when a bound for the disturbance acting over the system cannot be known, or when they are unmatched to the control input. This is precisely the case of system (1.1), which has matched and unmatched perturbations. The ISS property guarantees the robustness against any kind of bounded perturbations even if the bound is unknown, but in general this property cannot be proved for the sliding-mode controllers. This chapter will be devoted to the analysis of the ISS properties of

two sliding-mode controllers, the first is a conventional sliding-mode controller to which a linear term has been added, and the second one is the Super-Twisting algorithm (STA), which provides not only finite-time convergence of the nominal sliding variable, but also offers the possibility of implementing a continuous control signal.

In order to better illustrate the utility of exploring the ISS properties of SMC, the following example will be presented:

Consider the system

$$\dot{x} = u + w, \quad x(0) = 0, \quad (4.1)$$

where x is the state variable, u is the control input, and w is a growing disturbance.

Figure 4.1 illustrates the behavior of the trajectories of system (4.1) when the control input is defined as $u = -x$ (continuous line), $u = -\text{sign}(x)$ (dotted line), and $u = -x - \text{sign}(x)$ (dashed line), as the input w grows. When the control is simply a linear function of the state, the ultimate bound on the state starts to grow as soon as the disturbance is different from zero. In the second case, when the control is only a discontinuous function of the state, it is capable of forcing the trajectories to the origin for some values of the perturbation, but once it surpasses a certain level (equal to one in our example), the trajectories grow unboundedly. On the other hand, when the conventional sliding-mode controller is combined with the linear term, the trajectories can remain at the origin for some values of the disturbance, and then the ultimate bound grows with the perturbation.

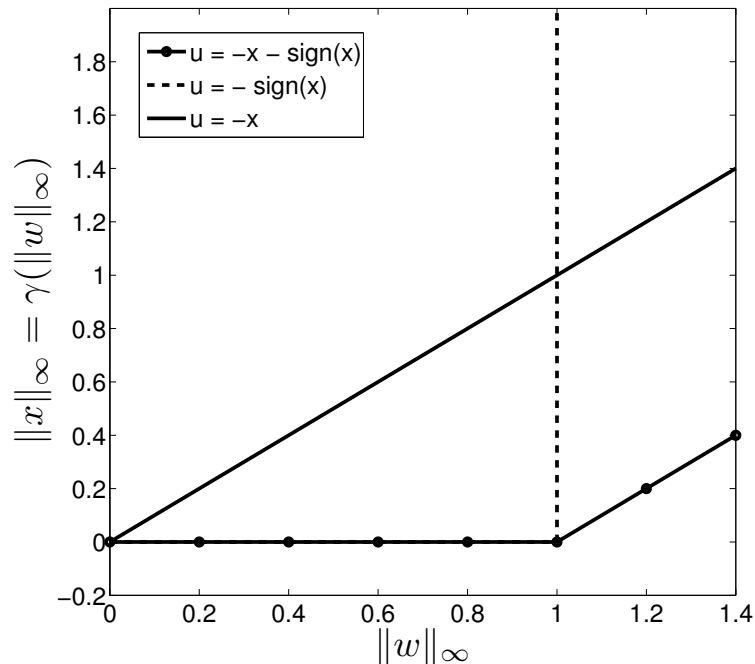

Figure 4.1: Behavior of the trajectories of x in the presence of a growing input w with different control laws.

4.1 Conventional Sliding Mode Controller with added linear term

In this section a controller as the one mentioned in the motivational example will be used to take the trajectories of (1.1) exactly to zero in absence of perturbations. It will also be shown that the trajectories converge to a neighborhood of the origin when bounded matched and/or unmatched perturbations are present, of which a bound is not necessarily known, and that they remain there for all future time. In other words, this controller should be able to take the sliding variable σ to zero. Evidently, this approach will be used when σ is of relative degree one. The following theorem establishes conditions for the gains of the controller and the parameters of the sliding variable that guarantee

the GAS of system (1.1), and its ISS property in presence of bounded perturbations. This theorem also summarizes the results obtained in the previous chapters.

Theorem 3 *If for a linear, controllable and observable system (1.1), of dimension n , with an output y of relative degree $r \leq n$ and an unknown, bounded, external input w of relative degree r_w , satisfying either Assumption 2 or Assumption 3, the control input is selected as*

$$u = -k_l \sigma - k_n \text{sign}(\sigma),$$

where the sliding variable is defined as

$$\sigma = z_r - c_{r-1} z_{r-1} \cdots - c_2 z_2 - c_1 (z_1 - K_v \eta),$$

and $\dot{\eta} = A_\eta \eta - B_\eta y_v$, then, for every $w \in L_\infty$, there exist a \mathcal{K} function γ and a \mathcal{KL} function β such that the norm of the solutions, for all t will remain in a neighborhood of the origin given by [Sontag95]

$$\|x(t, x(0), w)\| \leq \beta(\|x(0)\|, t) + \gamma(\|w\|_\infty),$$

provided that the gains satisfy

$$k_l > \frac{2\|E_\Delta\| \|E_\sigma\| \lambda_{\max}^2(P_\Delta)}{\lambda_{\min}(P_\Delta) \lambda_{\min}(Q_\Delta)} \quad (4.2)$$

$$k_n > \|D_\sigma\| \bar{w}_\sigma, \quad (4.3)$$

and the parameters K_v , A_η , E_η and c_1, \dots, c_{r-1} are chosen according to either Lemma 6, or 7

Proof Recall the coordinates defined in Section 3.4,

$$\dot{\Delta} = A_\Delta \Delta + E_\Delta \sigma + D_\Delta w_\Delta$$

$$\dot{\sigma} = A_\sigma \sigma + E_\sigma \Delta + w_\sigma + u,$$

and define the control signal

$$u = -k_l \sigma - k_n \text{sign}(\sigma). \quad (4.4)$$

where $k_l = A_\sigma + c_l$. From Lemmas 6, and 7 it is known that the subsystem $\Delta(\Delta, 0, w_\Delta)$ can be made GAS when $w_\Delta = 0$ and ISS otherwise, if the parameters of the sliding variable and those of η adequately. A Lyapunov function for this system is

$$V_\Delta = \Delta^\top P_\Delta \Delta$$

where P_Δ satisfies $A_\Delta P_\Delta + P_\Delta A_\Delta^\top < I$. Function V_Δ can be bounded as

$$\lambda_{\min}(P_\Delta) \leq V_\Delta \leq \lambda_{\max}(P_\Delta)$$

and, using Young's inequality (Lemma 1), the derivative over the trajectories of $\Delta(\Delta, \sigma, 0)$ satisfies

$$\begin{aligned} \dot{V}_\Delta &= -\|\Delta\|^2 + 2E_\Delta^\top P_\Delta \sigma \Delta \\ &\leq -\frac{1}{2}\|\Delta\|^2 + 2\lambda_{\max}(P_\Delta)\sigma^2. \end{aligned}$$

For subsystem $\sigma(\sigma, \Delta, w_\sigma, u)$ ¹ with (4.4), consider the Lyapunov candidate

$$V_\sigma = \frac{1}{2}\sigma^2.$$

If the non linear gain is chosen according to the classic sliding-mode theory as

$$k_n > \|D_\sigma\|\bar{w}_\sigma,$$

where $\|w_\sigma\| \leq \bar{w}_\sigma$, and the constant \bar{w}_σ is known², the directional derivative of V_σ satisfies

$$\begin{aligned} \dot{V}_\sigma &= \sigma E_\sigma \begin{bmatrix} \rho \\ \phi \end{bmatrix} + \sigma D_\sigma w_\sigma + \sigma(-k_l \sigma - k_n \text{sign}(\sigma)) \\ &\leq \left(\frac{\|E_\sigma\|}{2} - k_l \right) \sigma^2 + \frac{\|E_\sigma\|}{2} \|\Delta\|^2 \end{aligned}$$

¹Note that w_σ represents the matched component of the disturbance w in the sliding variable. If the disturbances satisfy the relative degree condition, then $w_\sigma = w_z$.

²In most of the sliding-mode literature, the knowledge of an upper bound of the matched disturbance is required for the gain design. In this work we consider the case when \bar{w}_σ is indeed known, and take it into account for the design, but we also consider the case when this constant is not known. In a real-life case, the designer can make an educated guess of the value of \bar{w}_σ , depending on the specific application and use this for the design without worrying that a miscalculation could destroy the stability achieved by the virtual control and the rest of the design, since an ISS behavior of the complete system with respect to the disturbance w will be present.

Defining four class \mathcal{K}_∞ functions

$$\begin{aligned} a_\Delta(\tau) &:= \frac{1}{\lambda_{\max}(P_\Delta)} \tau \\ \theta_\Delta(\tau) &:= 4\|P_\Delta\| \tau \\ a_\sigma(\tau) &:= \left(\frac{\|E_\sigma\|}{2} - k_l \right) \tau \\ \theta_\sigma(\tau) &:= \frac{\|E_\sigma\|}{2\lambda_{\min}(P_\Delta)} \tau, \end{aligned}$$

the derivatives of V_σ and V_Δ can be expressed as

$$\begin{aligned} \dot{V}_\Delta &\leq -a_\Delta(V_\Delta) + \theta_\Delta(V_\sigma) \\ \dot{V}_\sigma &\leq -a_\sigma(V_\sigma) + \theta_\sigma(V_\Delta). \end{aligned}$$

From Corollary 1 of Theorem 2, the condition (4.2) for the linear gain k_l is obtained.

4.1.1 Example and Numerical Simulations

Consider a damped double mass-spring system as the one shown in Figure 4.2.

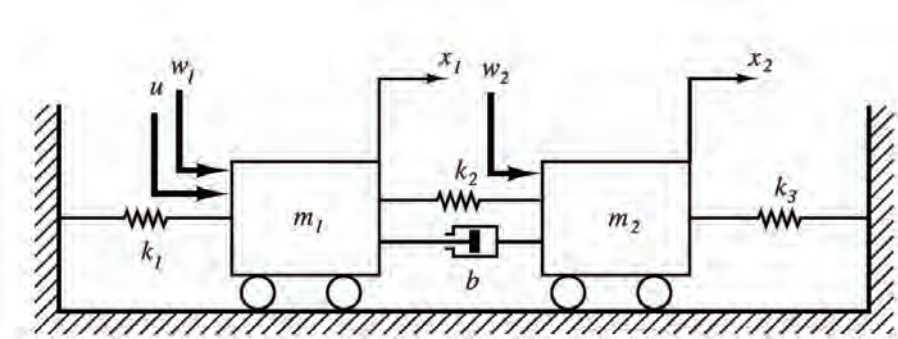

Figure 4.2: Perturbed Damped Double Mass-Spring.

The state space representation of this system can be written as

Parameter	Value	Parameter	Value
m_1	0.8	k_1	0.4
m_2	0.5	k_2	0.5
b	0.6	k_3	0.4

Table 4.1: Parameters for system (5.8)

$$\begin{bmatrix} \dot{x}_1 \\ \dot{x}_2 \\ \dot{x}_3 \\ \dot{x}_4 \end{bmatrix} = \begin{bmatrix} 0 & 1 & 0 & 0 \\ -\frac{k_1+k_2}{m_1} & -\frac{b}{m_1} & \frac{k_2}{m_1} & \frac{b}{m_1} \\ 0 & 0 & 0 & 1 \\ \frac{k_2}{m_2} & \frac{b}{m_2} & -\frac{k_2+k_3}{m_2} & -\frac{b}{m_2} \end{bmatrix} \begin{bmatrix} x_1 \\ x_2 \\ x_3 \\ x_4 \end{bmatrix} + \begin{bmatrix} 0 \\ \frac{1}{m_1} \\ 0 \\ 0 \end{bmatrix} u + \begin{bmatrix} 1 & 0 \\ 0 & 0 \\ 0 & 0 \\ 0 & 1 \end{bmatrix} \begin{bmatrix} w_1 \\ w_2 \end{bmatrix}, \quad (4.5)$$

$$y = \begin{bmatrix} 1 & 0 & 0 & 0 \end{bmatrix} \begin{bmatrix} x_1 \\ x_2 \\ x_3 \\ x_4 \end{bmatrix},$$

where x_1 and x_2 represent the position of each of the carts, x_3 and x_4 their respective velocity, y is the measured output and w_1 and w_2 are a pair of bounded unknown inputs. This system clearly has relative degree $r_u = 2$, and the perturbations satisfy the relative degree condition. Suppose that the system has the parameters shown in Table 4.1. For simplicity of this academic example it is assumed that all the units of the parameters are normalized so only its magnitudes are provided. A transformation

$$\begin{bmatrix} \xi \\ z \end{bmatrix} = Tx, \quad T = \begin{bmatrix} 0 & 0 & 1 & 0 \\ -1.2 & 0 & 0 & 1 \\ 1 & 0 & 0 & 0 \\ 0 & 1 & 0 & 0 \end{bmatrix}$$

takes the system to its Output Normal Form

$$\begin{bmatrix} \dot{\xi}_1 \\ \dot{\xi}_2 \\ \dot{z}_1 \\ \dot{z}_2 \end{bmatrix} = \begin{bmatrix} 0 & 1 & 0.12 & 0 \\ -1.8 & -1.2 & -0.44 & 0 \\ 0 & 0 & 0 & 1 \\ 0.62 & 1.5 & 0.67 & -0.75 \end{bmatrix} \begin{bmatrix} \xi_1 \\ \xi_2 \\ z_1 \\ z_2 \end{bmatrix} + \begin{bmatrix} 0 \\ 0 \\ 0 \\ 1.25 \end{bmatrix} u + \begin{bmatrix} 0 & 1 \\ 0 & 0 \\ 0 & 0 \\ 1 & 0 \end{bmatrix} \begin{bmatrix} w_1 \\ w_2 \end{bmatrix}$$

$$y = z_1.$$

System (5.8) is controllable and observable for the parameters of Table 4.1. Then, a controllable and observable reduced order system derived from it is

$$\begin{bmatrix} \dot{\xi}_1 \\ \dot{\xi}_2 \end{bmatrix} = \begin{bmatrix} 0 & 1 \\ -1.8 & -1.2 \end{bmatrix} \begin{bmatrix} \xi_1 \\ \xi_2 \end{bmatrix} + \begin{bmatrix} 0.12 \\ -0.44 \end{bmatrix} u_v + \begin{bmatrix} w_1 \\ 0 \end{bmatrix}$$

$$y_v = \begin{bmatrix} 0.62 & 1.5 \end{bmatrix} \begin{bmatrix} \xi_1 \\ \xi_2 \end{bmatrix} + w_2.$$

The closed loop (2.7), for the example of system (5.8) has the form

$$\begin{aligned}
\begin{bmatrix} \dot{\xi}_1 \\ \dot{\xi}_2 \end{bmatrix} &= \begin{bmatrix} 0 & 1 \\ -1.8, & -1.2 \end{bmatrix} \begin{bmatrix} \xi_1 \\ \xi_2 \end{bmatrix} + \begin{bmatrix} 1.2 k_{v1} & 1.2 k_{v2} \\ -0.44 k_{v1} & -0.44 k_{v2} \end{bmatrix} \begin{bmatrix} \eta_1 \\ \eta_2 \end{bmatrix} + \\
&+ \begin{bmatrix} 0.12 \\ -0.44 \end{bmatrix} \phi_1 + \begin{bmatrix} 0 \\ w_2 \end{bmatrix} \\
\begin{bmatrix} \dot{\eta}_1 \\ \dot{\eta}_2 \end{bmatrix} &= \begin{bmatrix} a_{\eta 11} & a_{\eta 12} \\ a_{\eta 21} & a_{\eta 22} \end{bmatrix} \begin{bmatrix} \eta_1 \\ \eta_2 \end{bmatrix} + \begin{bmatrix} 0.62 b_{\eta 1} & 1.5 b_{\eta 1} \\ 0.62 b_{\eta 2} & 1.5 b_{\eta 2} \end{bmatrix} \begin{bmatrix} \xi_1 \\ \xi_2 \end{bmatrix} + \begin{bmatrix} b_{\eta 1} w_1 \\ b_{\eta 2} w_1 \end{bmatrix} \\
\dot{\phi}_1 &= -c_1 \phi_1 + \begin{bmatrix} -0.62 b_{\eta 1} k_{v1} - 0.62 b_{\eta 2} k_{v2} \\ -1.5 b_{\eta 1} k_{v1} - 1.5 b_{\eta 2} k_{v2} \end{bmatrix}^\top \begin{bmatrix} \xi_1 \\ \xi_2 \end{bmatrix} + \\
&+ \begin{bmatrix} -a_{\eta 11} k_{v1} - a_{\eta 21} k_{v2} \\ -a_{\eta 12} k_{v1} - a_{\eta 22} k_{v2} \end{bmatrix}^\top \begin{bmatrix} \eta_1 \\ \eta_2 \end{bmatrix} + \sigma \\
\dot{\sigma} &= (c_1 - 0.75)\sigma + \begin{bmatrix} 0.62 - 0.62 b_{\eta 2} c_1 k_{v2} - 0.62 b_{\eta 1} c_1 k_{v1} \\ 1.5 - 1.5 b_{\eta 2} c_1 k_{v2} - 1.5 b_{\eta 1} c_1 k_{v1} \end{bmatrix}^\top \begin{bmatrix} \xi_1 \\ \xi_2 \end{bmatrix} + \\
&+ \begin{bmatrix} 0.68 k_{v1} - a_{\eta 11} c_1 k_{v1} - a_{\eta 21} c_1 k_{v2} \\ 0.68 k_{v2} - a_{\eta 12} c_1 k_{v1} - a_{\eta 22} c_1 k_{v2} \end{bmatrix}^\top \begin{bmatrix} \eta_1 \\ \eta_2 \end{bmatrix} + \\
&+ (0.68 - c_1^2 - 0.75 c_1)\phi + u + w_1,
\end{aligned}$$

A sliding surface of relative one is chosen for the example of system (5.8), that is,

$$\sigma = \dot{z}_1 - c_1 \left(z_1 - \begin{bmatrix} k_{v1} & k_{v2} \end{bmatrix} \begin{bmatrix} \eta_1 \\ \eta_2 \end{bmatrix} \right).$$

Then the augmented system (2.11) is

$$\begin{aligned}
\begin{bmatrix} \dot{\xi}_1 \\ \dot{\xi}_2 \end{bmatrix} &= \begin{bmatrix} 0 & 1 \\ -1.8, & -1.2 \end{bmatrix} \begin{bmatrix} \xi_1 \\ \xi_2 \end{bmatrix} + \begin{bmatrix} 1.2 k_{v1} & 1.2 k_{v2} \\ -0.44 k_{v1} & -0.44 k_{v2} \end{bmatrix} \begin{bmatrix} \eta_1 \\ \eta_2 \end{bmatrix} + \begin{bmatrix} 0.12 \\ -0.44 \end{bmatrix} \phi_1 \\
\begin{bmatrix} \dot{\eta}_1 \\ \dot{\eta}_2 \end{bmatrix} &= \begin{bmatrix} a_{\eta 11} & a_{\eta 12} \\ a_{\eta 21} & a_{\eta 22} \end{bmatrix} \begin{bmatrix} \eta_1 \\ \eta_2 \end{bmatrix} + \begin{bmatrix} 0.62 b_{\eta 1} & 1.5 b_{\eta 1} \\ 0.62 b_{\eta 2} & 1.5 b_{\eta 2} \end{bmatrix} \begin{bmatrix} \xi_1 \\ \xi_2 \end{bmatrix} \\
\dot{\phi}_1 &= -c_1 \phi_1 + \begin{bmatrix} -0.62 b_{\eta 1} k_{v1} - 0.62 b_{\eta 2} k_{v2} \\ -1.5 b_{\eta 1} k_{v1} - 1.5 b_{\eta 2} k_{v2} \end{bmatrix}^\top \begin{bmatrix} \xi_1 \\ \xi_2 \end{bmatrix} + \\
&+ \begin{bmatrix} -a_{\eta 11} k_{v1} - a_{\eta 21} k_{v2} \\ -a_{\eta 12} k_{v1} - a_{\eta 22} k_{v2} \end{bmatrix}^\top \begin{bmatrix} \eta_1 \\ \eta_2 \end{bmatrix} + \sigma \\
\dot{\sigma} &= (c_1 - 0.75)\sigma + \begin{bmatrix} 0.62 - 0.62 b_{\eta 2} c_1 k_{v2} - 0.62 b_{\eta 1} c_1 k_{v1} \\ 1.5 - 1.5 b_{\eta 2} c_1 k_{v2} - 1.5 b_{\eta 1} c_1 k_{v1} \end{bmatrix}^\top \begin{bmatrix} \xi_1 \\ \xi_2 \end{bmatrix} + \\
&+ \begin{bmatrix} 0.68 k_{v1} - a_{\eta 11} c_1 k_{v1} - a_{\eta 21} c_1 k_{v2} \\ 0.68 k_{v2} - a_{\eta 12} c_1 k_{v1} - a_{\eta 22} c_1 k_{v2} \end{bmatrix}^\top \begin{bmatrix} \eta_1 \\ \eta_2 \end{bmatrix} + (0.68 - c_1^2 - 0.75 c_1)\phi + u,
\end{aligned}$$

For this example the *priority to the state* option will be chosen. Then, the parameters K_v , A_η , and E_η will be defined through an H_∞ minimization of a transfer function $\|T_{w, [\xi, u_v]}^T\|_\infty$, which will be achieved by the resolution of a pair of Riccati equations. This minimization gives the following values for the mentioned parameters

$$A_\eta = \begin{bmatrix} -0.54 & 1.4 \\ -2.05 & -2.41 \end{bmatrix}, \quad B_\eta = \begin{bmatrix} -0.28 \\ 1.29 \end{bmatrix}, \quad K_v = \begin{bmatrix} -0.23 & 0.03 \end{bmatrix}$$

This defines the parameters of system Δ_1 as

$$A_{\Delta 1} = \begin{bmatrix} 0 & 1 & -0.27 & 0.032 \\ -1.8 & -1.2 & 0.1 & -0.012 \\ -0.18 & -0.42 & -0.54 & 1.4 \\ 0.81 & 1.9 & -2.0 & -2.4 \end{bmatrix} \quad E_{\Delta 1} = \begin{bmatrix} 1.2 \\ -0.44 \end{bmatrix}.$$

The eigenvalues of $A_{\Delta 1}$ are

$$\lambda(A_{\Delta 1}) = \begin{bmatrix} -1.3 - 1.3i \\ -1.3 + 1.3i \\ -0.79 - 1.2i \\ -0.79 + 1.2i \end{bmatrix}$$

and the ISS gain of the nominal $\Delta 1$ is

$$\gamma_{\Delta 1} = 33$$

Choosing $c_1 = 15$, the conditions of Lemma 7 are satisfied with

$$0.0281 = \frac{2 \lambda_{max}^2(P_\phi) \|E_{\phi 1}, E_{\phi 2}\|}{\lambda_{min}(P_\phi) \lambda_{min}(Q_\phi)} < \frac{1}{\gamma_{\Delta 1}} = \frac{1}{33}$$

and the ISS gain of the complete system Δ is

$$\gamma_\Delta = 162.59.$$

A bound for the perturbation w_2 will be assumed as $\bar{w}_2 = 1.5$. If the gains for the controller (4.4) are chosen as

$$k_n = 1.6, \quad \text{and} \quad k_l = 188,$$

the conditions of Theorem 3 are satisfied. This is validated through the following simulation results

The disturbance signals for the numerical simulations were chosen as $w_1 = 1.2 + 0.6 \sin(t)$ and $w_2 = 0.8 + 0.5 \sin(t)$. The initial conditions were chosen as $x_1 = 1$, $x_2 = 0.6$, $x_3 = 0.5$, and $x_4 = .6$.

Figure 4.3 shows how the trajectories of the system remain in a bounded neighborhood of the origin, in presence of the matched and also the unmatched disturbances. Figure 4.4 shows the control signal which is discontinuous for most of the simulation time, and the zoom shows the period of time where the linear term acts, before reaching the

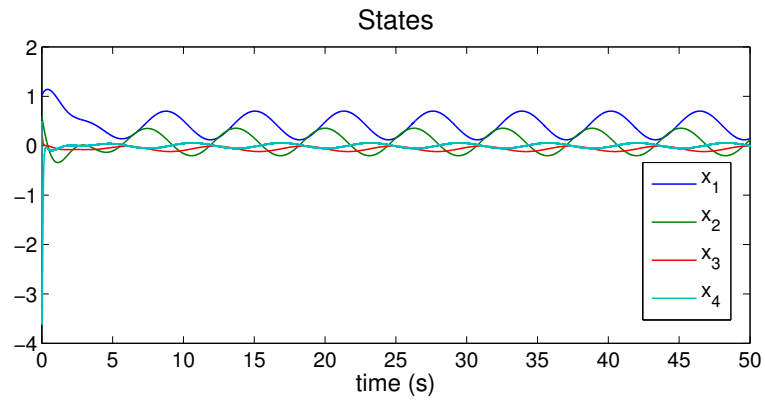

Figure 4.3: State trajectories of the damped double mass-spring system (5.8).

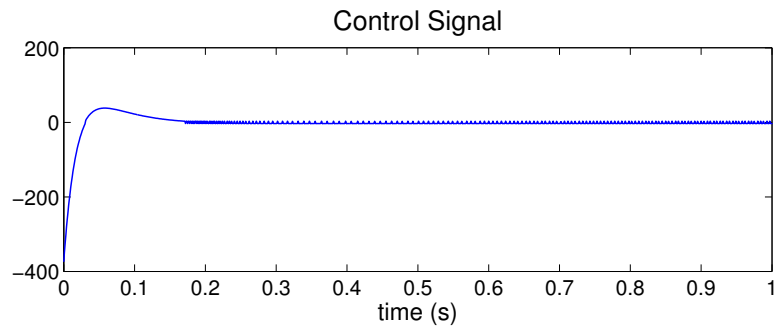

Figure 4.4: Control signal $u = -188\sigma - 1.6\text{sign}(\sigma)$, from time 0s to 1s which illustrates the action of the linear part of u .

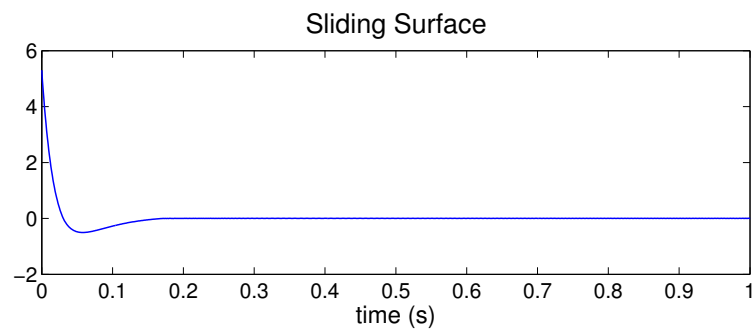

Figure 4.5: Trajectory of the sliding variable σ , from time 0s to 1s which illustrates the behavior before reaching the sliding mode.

sliding-mode. Figure 4.5 shows the sliding surface converging to zero. The reaching time shown in the zoom coincides with the period of time where the linear control acts.

Next, the perturbations were augmented ($w_1 = 12 + 6 \sin(t)$, $w_2 = 8 + 5 \sin(t)$), and both the linear and the non-linear selected gains were maintained the same as before. This scenario would be problematic for a first-order sliding-mode controller with the selected gain, but Figure 4.6(a) shows that the combination of the linear term and the discontinuous one can still maintain the trajectories of the system in a neighborhood of the origin, showing an ISS behavior. Figure 4.6(b) shows the control signal. It can be seen that the control signal alternates between the discontinuous term and the linear one. This switching corresponds to the moments where the sliding-mode is lost and regained, as shown in Figure 4.6(c).

4.2 Super Twisting Controller

The Super-Twisting (ST), a very popular second-order sliding-mode algorithm, was introduced in [Levant93], which is one of the most cited works in the sliding-mode literature, with over 1500 mentions. The algorithm has been used for control, differentiation and observation numerous times. Its two most popular properties are that it offers a continuous control signal and that it is robust against matched perturbations that are bounded by a known constant L , provided that its gains are chosen adequately, depending on the value of this L . The downside of the implementation of the STA is that up until recently the available stability proofs were done by geometrical methods [Levant07], using the homogeneity of a special form of the algorithm [Levant05], or non-differentiable Lyapunov functions [Moreno12]. Very few years ago an absolutely differentiable Lyapunov function for the STA appeared in [Sánchez14] which opened the possibility of proving, among other properties, the ISS. In this section we will consider the STA as a control law for (1.1) and it will be shown that if its gains satisfy certain conditions, the trajectories of the system will go to zero in absence of perturbations, and to a neighborhood of the origin in presence

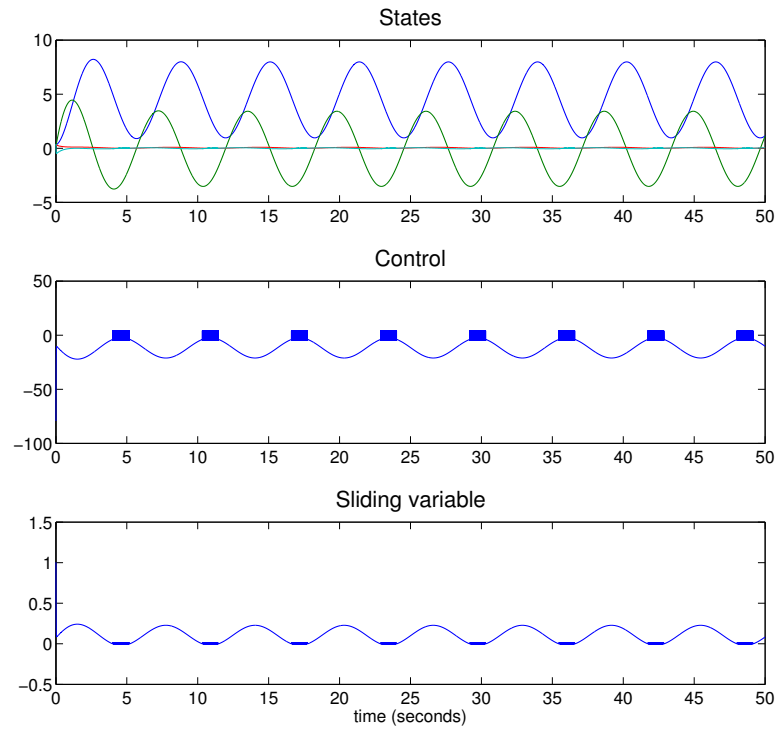

Figure 4.6: System's behavior with perturbations whose magnitude surpasses the magnitude of the non linear gain ($w_1 = 12 + 6 \sin(t)$, $w_2 = 8 + 5 \sin(t)$): (a) State trajectories of (5.8). (b) Control signal. (c) Trajectory of the sliding variable

of matched and/or unmatched disturbances that satisfy either condition 2 or 3 when the sliding surface is adequately chosen. The following theorem states such conditions:

Theorem 4 *If for a linear, controllable and observable system (1.1), of dimension n , with an output y of relative degree $r \leq n$ and an unknown, bounded, external input w of relative degree r_w , satisfying either Assumption 2 or Assumption 3, the control input is selected as*

$$\begin{aligned} u &= -A_\sigma \sigma - k_1 [\sigma]^{\frac{1}{2}} + \nu \\ \dot{\nu} &= -k_2 [\sigma]^0 \end{aligned} \quad (4.6)$$

where the sliding variable is defined as

$$\sigma = z_r - c_{r-1} z_{r-1} \cdots - c_2 z_2 - c_1 (z_1 - K_v \eta),$$

and $\dot{\eta} = A_\eta \eta - B_\eta y_v$, then, for every $w \in L_\infty$, there exist a \mathcal{K} function γ and a \mathcal{KL} function β such that the norm of the solutions, for all t will remain in a neighborhood of the origin given by [Sontag95]

$$\|x(t, x(0), w)\| \leq \beta(\|x(0)\|, t) + \gamma(\|w\|_\infty),$$

provided that the gains satisfy

$$2\bar{\gamma} \|E_\Delta\| \|E_\sigma\| \lambda_{max}^2(P_\Delta) \left(\frac{\epsilon_1}{\epsilon_2}\right)^{\frac{1}{3}} \theta \lambda_{min}(P_\Delta) \lambda_{min}(Q_\Delta) \min\{\bar{\delta}_1, \bar{\delta}_2, d_1, d_2\} < 1 \quad (4.7)$$

and the parameters K_v , A_η , E_η and c_1, \dots, c_{r-1} are chosen according to either Lemma 6, or 7.

Proof Recall the coordinates

$$\begin{aligned} \dot{\Delta} &= A_\Delta \Delta + E_\Delta \sigma + D_\Delta w_\Delta \\ \dot{\sigma} &= A_\sigma \sigma + E_\sigma \Delta + w_z + u, \end{aligned}$$

and consider the control law (4.6). The closed loop is

$$\begin{aligned}\dot{\Delta} &= A_{\Delta}\Delta + E_{\Delta}\sigma + D_{\Delta}w_{\Delta} \\ \dot{\sigma} &= E_{\sigma}\Delta + w_z - k_1[\sigma]^{\frac{1}{2}} + \nu \\ \dot{\nu} &= -k_2[\sigma]^0.\end{aligned}\tag{4.8}$$

The Lyapunov function proposed in [Sánchez14] is

$$V_{\sigma} = \alpha_1|\sigma|^{\frac{3}{2}} - \alpha_{12}[\sigma][\nu] + \alpha_2|\nu|^3,\tag{4.9}$$

and its derivative over the trajectories of (4.8) when $\Delta = 0$, and $w_z = 0$ is

$$\begin{aligned}\frac{\partial V}{\partial t}f(\sigma, \nu, 0, 0) &= (-\gamma_1 k_1 - \gamma_{12} k_2) |\sigma| + (\gamma_1 + \gamma_{12} k_1)[\sigma]^{\frac{1}{2}} \nu - \gamma_{12} |\nu|^2 + \\ &\quad - \gamma_2 k_2 \text{sign}(\sigma\nu) |\nu|^2 \\ &= -W(\sigma, \nu).\end{aligned}$$

In the same work it is proven that (4.9) and $W(\sigma, \nu)$ are positive definite if the following inequalities are satisfied:

$$\begin{aligned}3\gamma_1 k_1 &> \gamma_{12} k_2 \\ \gamma_2 > \gamma_{12} &> 3\gamma_2 k_2 \\ \gamma_1 &> 2\gamma_{12} \\ 4\gamma_{12} + 12\gamma_2 k_2 &> 3\gamma_1 2\gamma_{12} k_2 \\ 3\gamma_1 k_1 + 6\gamma_2 k_2 + 2\gamma_{12} &> 6\gamma_1 + \gamma_{12} k_2.\end{aligned}\tag{4.10}$$

If $\Delta \neq 0$, and $w_z = w_{\Delta} = 0$, i.e. the unperturbed case, the time derivative of (4.9) over the trajectories of (4.8) is

$$\begin{aligned}\dot{V}_{\sigma} &= \gamma_1 [\sigma]^{\frac{1}{2}} \text{sign}(\sigma) \left(E_{\sigma} \Delta - k_1 [\sigma]^{\frac{1}{2}} + \nu \right) - \gamma_{12} [\sigma] (-k_2 [\sigma]^0) + \\ &\quad - \gamma_{12} [\nu] \left(E_{\sigma} \Delta - k_1 [\sigma]^{\frac{1}{2}} + \nu \right) + \gamma_2 |\nu|^2 \text{sign}(\sigma) (-k_2 [\sigma]^0) \\ &= -W(\sigma, \nu) + \left(\gamma_1 [\sigma]^{\frac{1}{2}} - \gamma_{12} \nu \right) E_{\sigma} \Delta\end{aligned}$$

By means of homogeneous norms, the Cauchy-Schwartz inequality and some algebraic manipulation, it can be proved that

$$\dot{V}_\sigma \leq -(1 - \theta)W(\sigma, \nu), \quad \forall \sigma, \nu$$

if

$$\|[\sigma]^{\frac{1}{2}}, \nu\| \geq \frac{\bar{\gamma} \|E_\sigma\|}{\theta \min\{\bar{\delta}_1, \bar{\delta}_2, d_1, d_2\}} |\Delta|$$

where

$$\bar{\gamma} = \|\gamma_1, \gamma_{12}\| \quad \theta = (0, 1) \quad (4.11)$$

$$d_1 = \lambda_{\min} \left\{ \begin{bmatrix} \delta_1 & -\frac{\delta_{12}}{2} \\ -\frac{\delta_{12}}{2} & \delta_2 \end{bmatrix} \right\} \quad d_2 = \lambda_{\min} \left\{ \begin{bmatrix} \bar{\delta}_1 & -\frac{\bar{\delta}_{12}}{2} \\ -\frac{\bar{\delta}_{12}}{2} & \bar{\delta}_2 \end{bmatrix} \right\} \quad (4.12)$$

$$\delta_1 = \gamma_1 k_1 - \gamma_{12} k_2 + \gamma_{12} L \quad \delta_2 = \gamma_{12} + \gamma_2 k_2 - \gamma_2 L \quad (4.13)$$

$$\bar{\delta}_1 = \gamma_1 k_1 - \gamma_{12} k_2 - \gamma_{12} L \quad \bar{\delta}_2 = \gamma_{12} + \gamma_2 k_2 + \gamma_2 L \quad (4.14)$$

$$\delta_{12} = \gamma_1 + \gamma_{12} k_1 \quad \bar{\delta}_{12} = \gamma_{12} - \gamma_2 k_2 - \gamma_2 L \quad (4.15)$$

also, using homogeneous norms, the function V_σ can be bounded as

$$\epsilon_1 \|[\sigma]^{\frac{1}{2}}, \nu\|^3 \leq V_\sigma \leq \epsilon_2 \|[\sigma]^{\frac{1}{2}}, \nu\|^3,$$

where

$$\epsilon_1 = \min_s(h(s)), \quad \epsilon_2 = \max_s(h(s)), \quad (4.16)$$

$$h(s) = \frac{2}{3}\gamma_1(1 - s^2)^{\frac{3}{2}} + \gamma_{12}(1 - s^2)s + \frac{1}{3}\gamma_2|s|^3 \quad (4.17)$$

Then, following definition 2, (4.9) is an ISS-Lyapunov function for (4.8), and the ISS gain is given by

$$\gamma_\sigma(\Delta) = \frac{\bar{\gamma} \|E_\sigma\| \left(\frac{\epsilon_1}{\epsilon_2}\right)^{\frac{1}{3}}}{\theta \min\{\bar{\delta}_1, \bar{\delta}_2, d_1, d_2\}} |\Delta|. \quad (4.18)$$

Then, the feedback interconnection of Δ - σ can be made stable if the gains of each subsystem, and the parameters γ_1 , γ_{12} , γ_2 are chosen such that the inequalities (4.10) are

satisfied, as well as the small gain condition

$$\gamma_{\Delta}\gamma_{\sigma} < 1,$$

where γ_{Δ} is as in the proof of Theorem 3. From the above condition, (4.7) is obtained.

4.2.1 Example and Numerical Simulations

Consider the unstable system

$$\begin{aligned} \dot{\xi} &= -9\xi + 1.4x_1 + w_1 \\ \dot{x}_1 &= x_2 \end{aligned} \tag{4.19}$$

$$\begin{aligned} \dot{x}_2 &= 2.5x_1 + 1.6x_2 - 0.1\xi + w_2 \\ y &= x_1. \end{aligned} \tag{4.20}$$

This system is in the ONF, of order 3, and the output has relative degree 2 with respect to the input. A relative degree one sliding surface is chosen as

$$\sigma = x_2 + c_1(y - k_v \eta),$$

where, since the zero dynamics is of order one, the signal η is scalar and has the dynamics

$$\dot{\eta} = a_{\eta}\eta + b_{\eta}y_v,$$

as well as the virtual control $u_v = k_v\eta$. The parameters of the observer η , the sliding variable σ and the virtual controller are as:

$$a_{\eta} = -9.7$$

$$b_{\eta} = 20$$

$$k_v = -0.7442,$$

which leads to the augmented system

$$\begin{aligned} \dot{\Delta} &= \begin{bmatrix} -9 & -1.0419 & 1.4 \\ 2 & -9.7 & 0 \\ 1.4884 & -7.2186 & -10.7258 \end{bmatrix} \Delta + \begin{bmatrix} 0 \\ 0 \\ 1 \end{bmatrix} \sigma + \begin{bmatrix} w_1 \\ w_2 \\ 0 \end{bmatrix} \\ \dot{\sigma} &= \begin{bmatrix} 1 & -79.1056 & -181.5687 \end{bmatrix} \Delta + 12.3258 \sigma + w_2 + u. \end{aligned}$$

This choice of parameters is made giving priority to the control, that is, some values that make the nominal part of Δ stable, while trying to minimize its ISS gain, which can be calculated as:

$$\gamma_{\Delta} = 0.3189.$$

The control u is defined by the STA as:

$$\begin{aligned} u &= -u_e - k_1[\sigma]^{\frac{1}{2}} + \nu \\ \dot{\nu} &= -k_2[\sigma]^0, \end{aligned}$$

where $u_e = 12.3258 \sigma$. Assuming a bound for the perturbation $|w_1| < L$ as $L = 1$, a set of gains for the controller, and parameters for the Lyapunov function (4.9) that satisfy the set of inequalities (4.10) is

$$k_1 = 3.4$$

$$k_2 = 1.4$$

$$\gamma_1 = 2.6$$

$$\gamma_{12} = 1$$

$$\gamma_2 = 0.45.$$

From (4.18) the ISS gain of the closed loop of σ with the chosen control u can be calculated as

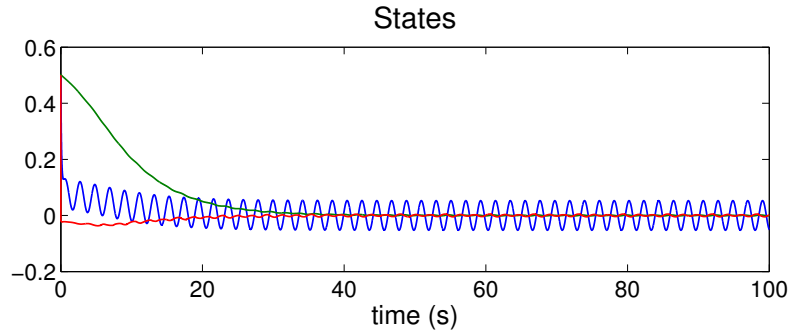

Figure 4.7: State trajectories of system (4.19) with the STA.

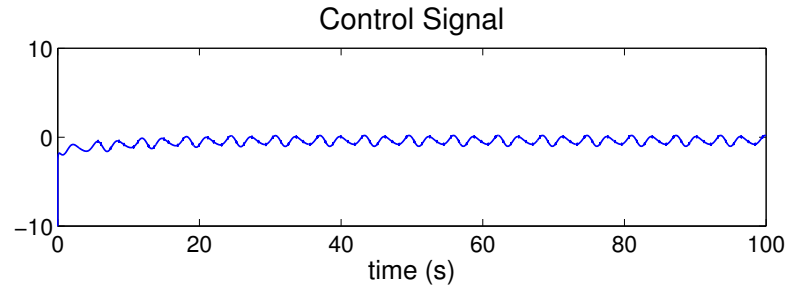

Figure 4.8: *Super-Twisting* Algorithm

$$\gamma_\sigma = 2.7,$$

satisfying the conditions of Theorem 4. This is validated through the following simulation results

The disturbance signals for the numerical simulations were chosen as $w_1 = 0.5 \sin(t)$ and $w_2 = 0.4 + 0.5 \sin(t)$. The initial conditions were chosen as $x_1 = 0.5$, $x_2 = 0.5$, $x_3 = 0.5$, and $x_4 = 0.5$.

Figure 4.7 shows how the trajectories of the system remain in a bounded neighborhood of the origin, in presence of the matched and also the unmatched disturbances. Figure 4.8 shows the control signal which is continuous. Figure 4.9 shows the sliding surface converging to a neighborhood of the origin.

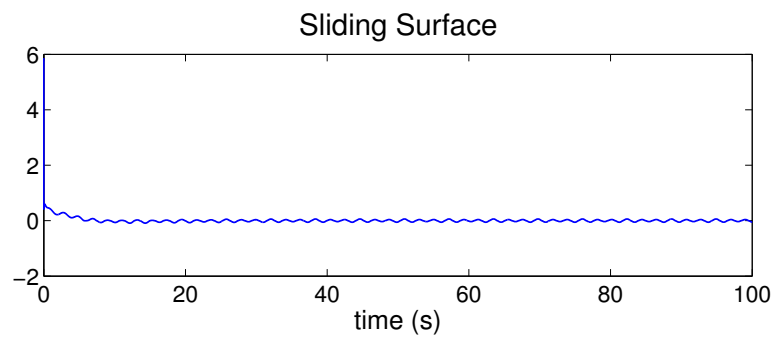

Figure 4.9: Trajectory of the sliding variable σ .

Next, the perturbations were augmented ($w_1 = 12 + 6 \sin(t)$, $w_2 = 8 + 5 \sin(t)$), and the selected gains were maintained. Figure 4.10 shows that the STA is able to maintain the trajectories of the system in a neighborhood of the origin, showing an ISS behavior. Figure 4.6(b) shows the continuous control signal, and 4.6(c) shows the sliding surface σ .

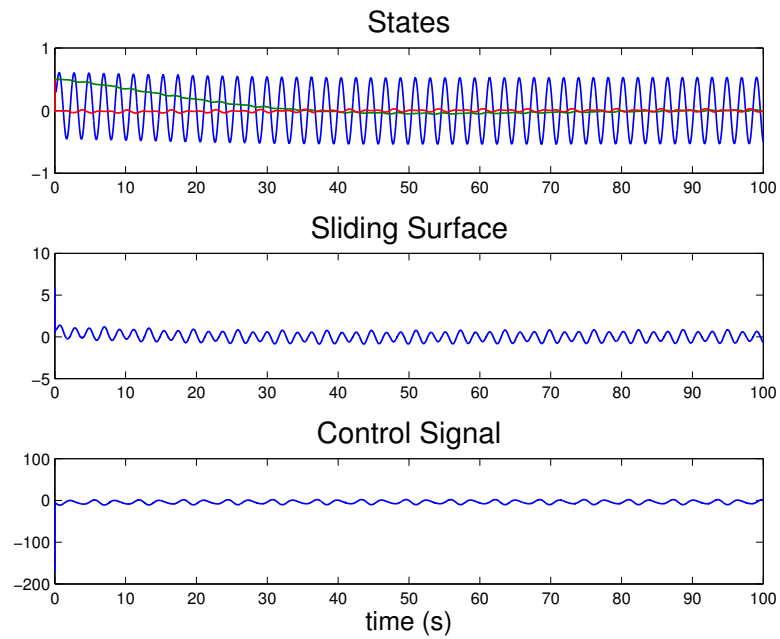

Figure 4.10: System's behavior with perturbations whose magnitude surpasses the magnitude of the non linear gain ($w_1 = 5 \sin(t)$, $w_2 = 4 + 5 \sin(t)$): (a) State trajectories of (4.19). (b) Control signal. (c) Trajectory of the sliding variable

Chapter 5

Stabilization of switched systems by linear feedbacks and its ISS properties

The study and implementation of systems that commute between different behavior schemes are interesting mathematical and technical challenges. The theoretical results appear in the literature gathered in the domains of variable structure, switched and hybrid systems, and a survey on the existing stability criteria can be found in [Shorten07]. This domain can be divided in two big groups: the systems whose switchings depend on the time, and those that operate under state-dependent switching laws. The latter group can also be divided in two: the systems with given switching laws, that need to be stabilized in some way, or those for which the design of a stabilizing switching law is required. Numerous works can be found that offer stability results based on different well-known strategies where the most utilized are Linear Matrix Inequalities (LMIs) and Lyapunov methods [Petttersson97, Johansson98, Wicks94]. In this chapter we will focus on state dependent switching systems and, in particular, those whose switchings occur on the axes of its state

coordinates, in other words, in the instant when the sign of the state variables changes. The goal is to design a method for constructing a stabilizing control law for this class of systems, and to analyze its ISS properties. The main contributions of this chapter are

- The establishment of sufficient conditions for a linear stabilizer that ensures the stability of the switched system.
- The ISS gain based analysis of robustness against matched and unmatched perturbations.

5.1 Stability of an n -dimensional system with n signs

A stability proof for a class of n -dimensional systems, whose dynamics consist of the sum of a purely linear part and the signs of the state variables, will be developed in this section. This kind of systems can be written in the following form

$$\dot{x} = A_0x + A_1\text{sign}(x), \quad (5.1)$$

where $x \in \mathbb{R}^n$ is the state vector, $\vec{\text{sign}}(x) \in \mathbb{R}^n$ is a column defined as $\vec{\text{sign}}^T(x) := [\text{sign}(x_1) \ \dots \ \text{sign}(x_n)]$ and $A_0, A_1 \in \mathbb{R}^{n \times n}$ are real constant matrices. The stability check will be performed by establishing a sufficient LMI condition to construct a Lyapunov function for (5.1). To this end, the matrices $P \in \mathbb{R}^{n \times n}$, $G \in \mathbb{R}^{n \times n}$, $R \in \mathbb{R}^{n \times n}$, $r \in \mathbb{R}^{n \times n}$ and $M \in \mathbb{R}^{n \times n}$, and a constant μ must be defined in the following manner:

$$P := \begin{bmatrix} p_{11} & p_{12} & \dots & p_{1n} \\ p_{12} & p_{22} & \dots & p_{2n} \\ \vdots & \ddots & \ddots & \vdots \\ p_{1n} & p_{2n} & \dots & p_{nn} \end{bmatrix}, \quad G := \begin{bmatrix} g_1 & 0 & \dots & 0 \\ 0 & \ddots & \ddots & \vdots \\ \vdots & \ddots & \ddots & 0 \\ 0 & \dots & 0 & g_n \end{bmatrix} \quad (5.2)$$

$$R := 2A_1^T P + GA_0, \quad R_d := \text{diag}(R), \quad M := R_d + |R - \vec{R}_d|,$$

for some real constants $g_i, p_{ij}, i, j = 1, \dots, n$. The following theorem establishes the LMI conditions that the above defined parameters should satisfy in order to construct a Lyapunov function for (5.1).

Theorem 5 *Let the origin be the only equilibrium of (5.1), and the following pair of LMIs be satisfied*

$$A_0^T P + P A_0 = -Q, \quad M \vec{1}_{(n \times 1)} \leq 0,$$

for

$$P = P^T > 0, \quad Q = Q^T > 0, \quad G \geq 0, \quad G A_1 = 0.$$

Then, a function $V : \mathbb{R}^n \rightarrow \mathbb{R}$ defined as

$$V(x) := x^T P x + \sum_{i=1}^n g_i |x_i| \quad (5.3)$$

is a Lyapunov function for system (5.1), with a derivative estimate

$$\dot{V} \leq -x^T Q x.$$

Proof Since the matrix P is positive definite and G is positive semidefinite, then V is also positive definite and radially unbounded. The function V is locally Lipschitz continuous. Then, by Rademacher's theorem, it is differentiable almost everywhere in \mathbb{R}^n , and the derivative of V along the trajectories of (5.1) is

$$\begin{aligned} \dot{V} &= x^T (A_0^T P + P A_0) x + \vec{\text{sign}}^T(x) (A_1^T P + \frac{1}{2} G A_0) x + x^T (P A_1 + \frac{1}{2} A_0^T G) \vec{\text{sign}}(x) \\ &= x^T (A_0^T P + P A_0) x + \vec{\text{sign}}(x)^T R x. \end{aligned} \quad (5.4)$$

The Lyapunov equation $A_0^T P + P A_0 = -Q$ can be solved for $P = P^T > 0$, with $Q = Q^T > 0$ if and only if A_0 is a stable matrix. From the second part of (5.4) we have that

$$\begin{aligned} \vec{\text{sign}}(x)^T R x &= \sum_{i=1}^n \left[x_i \sum_{k=1}^n (\text{sign}(x_k) R_{k,i}) \right] \\ &\leq \sum_{i=1}^n \left[\left(R_{i,i} + \sum_{k \neq i, k=1}^n |R_{k,i}| \right) |x_i| \right] \end{aligned}$$

and with M as defined above, we get

$$R_{(i,i)} + \sum_{k \neq i}^n |R_{(k,i)}| \leq 0, \forall 1 \leq i \leq n \Leftrightarrow M^T \vec{1}_{(n \times 1)} \leq 0.$$

Thus,

$$\dot{V} \leq -x^T Q x,$$

and if the conditions of Theorem 5 are satisfied, the function V is positive definite for all x , and its derivative along the trajectories of (5.1) is negative definite.

Remark 5 *In the case of a given switched system with dynamics*

$$\begin{aligned} \dot{x} &= \bar{A}_{0s}x + A_{1s}\vec{\text{sign}}(x) + Bu \\ y &= x, \end{aligned}$$

a linear control $u = Kx$ can be designed such that the stability of the closed loop can be checked with the conditions of Theorem 5, for $A_{0s} = (\bar{A}_{0s} + BK)$ and A_{1s} . In this case, the considered class of switching occurs in the axes of the n -dimensional space. Further in this text it will also be considered the case when the switching surfaces are linear, but do not lay exactly in the axes of the space.

5.2 Perturbation Analysis and Input to State Stability

In this section we will prove that if system (5.1) satisfies the conditions of Theorem 5, it also admits the ISS property, which makes it robust to exogenous matched or unmatched bounded perturbations. It is important to note that while the boundedness of the external inputs is a fundamental condition for establishing the ISS property, the knowledge of its supremum norm is not necessary for the design. Consider system (5.1) with an unknown input function $\omega : \mathbb{R}_{\geq 0} \rightarrow \mathbb{R}^n$:

$$\dot{x} = A_0x + A_1\vec{\text{sign}}(x) + \omega. \quad (5.5)$$

Theorem 6 *If ω is essentially bounded, i.e. $\omega \in L_\infty$, and the conditions of Theorem 5 are satisfied, then (5.5) is ISS with an asymptotic gain $\gamma : \mathbb{R}_{\geq 0} \rightarrow \mathbb{R}_{\geq 0}$ given by*

$$\gamma(r) = \alpha_1^{-1} \circ \alpha_2 \circ \alpha_3^{-1} \circ \alpha_4(r),$$

where

$$\begin{aligned} \alpha_1(r) &:= \lambda_{\min}(P) r^2 \\ \alpha_2(r) &:= (\lambda_{\max}(P) r + \sqrt{n} \max\{g_i\}) r \\ \alpha_3(r) &:= (\lambda_{\min}(Q) - \epsilon_1 \lambda_{\max}(P)) r \\ \alpha_4(r) &:= \left(\frac{\lambda_{\max}(P)}{\epsilon_1} r + \sqrt{n} \max\{g_i\} \right) r. \end{aligned}$$

Proof The derivative of (5.3) over the trajectories of (5.5) is

$$\dot{V} = -x^T Q x + \text{sign}^T(x) R x + 2x^T P \omega + \text{sign}^T(x) G \omega.$$

For the above expression the following inequalities hold:

$$\begin{aligned} \text{sign}^T(x) R x &\leq 0, \\ -x^T Q x &\leq -\lambda_{\min}(Q) \|x\|^2, \\ 2x^T P \omega &\leq \lambda_{\max}(P) \left(\epsilon_1 \|x\|^2 + \frac{\|\omega\|^2}{\epsilon_1} \right) \quad \forall \epsilon_1 > 0, \\ \text{sign}^T(x) G \omega &\leq \sqrt{n} \max\{g_i\} \|\omega\|, \quad i = 1, \dots, n. \end{aligned}$$

From definition 5, V is an ISS-Lyapunov function for (5.5) with $\chi(r) = \alpha_3^{-1} \circ \alpha_4(r)$, since

$$\alpha_1(\|x\|) \leq V(x) \leq \alpha_2(\|x\|), \quad (5.6)$$

$$\dot{V} \leq -\alpha_3(\|x\|) + \alpha_4(\|\omega\|) \quad (5.7)$$

with $\alpha_1, \alpha_2, \alpha_3, \alpha_4 \in \mathcal{K}_\infty$, as defined in the theorem. Then, following the arguments of [Sontag89], the system is ISS and the asymptotic gain function is $\gamma(r)$.

5.2.1 Example

Consider two interconnected mechanical systems whose positions are given by variables x_1 and x_2 respectively, and suppose that the velocity of each of them can be controlled. The state space representation of this system can be written as

$$\begin{aligned} \begin{bmatrix} \dot{x}_1 \\ \dot{x}_2 \end{bmatrix} &= \begin{bmatrix} a_{11} & a_{12} \\ a_{21} & a_{22} \end{bmatrix} \begin{bmatrix} x_1 \\ x_2 \end{bmatrix} + \begin{bmatrix} w_1 \\ w_2 \end{bmatrix} + \begin{bmatrix} u_1 \\ u_2 \end{bmatrix} \\ y &= \begin{bmatrix} 1 & 0 \\ 0 & 1 \end{bmatrix} \begin{bmatrix} x_1 \\ x_2 \end{bmatrix}. \end{aligned} \quad (5.8)$$

System (5.8) is linear, and the switches will be added as control signals. Two perturbations are considered, $w_1 \in \mathbb{R}$ and $w_2 \in \mathbb{R}$, one on each of the systems. These perturbations are assumed to be bounded, but the value of their supremum norms is considered unknown. Suppose that the parameters of (5.8) are $a_{11} = -1$, $a_{12} = 0.5$, $a_{21} = 0.5$ and $a_{22} = -1$. If the control signals are chosen as

$$u_1 = -2 \operatorname{sign}(x_1) - \operatorname{sign}(x_2) \quad \text{and} \quad u_2 = -\operatorname{sign}(x_1) - 2 \operatorname{sign}(x_2), \quad (5.9)$$

then (5.8) can be written in the form (5.1) with

$$A_0 = \begin{bmatrix} -1 & 0.5 \\ 0.5 & -1 \end{bmatrix}, \quad \text{and} \quad A_1 = \begin{bmatrix} -2 & -1 \\ -1 & -2 \end{bmatrix}$$

Matrix A_0 is Hurwitz, so the Lyapunov equation can be satisfied for a positive definite matrix $P \in \mathbb{R}^{(2 \times 2)}$, with $Q = I_2$. Choosing $g_1 = g_2 = 0$, yields the product $M \begin{bmatrix} 1 & 1 \end{bmatrix}^\top = \begin{bmatrix} -0.67 & -0.67 \end{bmatrix}^\top$, whose every element is clearly negative. The conditions of Theorem 5 are satisfied. The left-hand side of Figure 5.1 shows the simulation results of the closed loop of (5.8) with (5.9), for the unperturbed case (upper-left), and when the perturbations are chosen as $w_1 = 1 + 0.5 \sin(t)$ and $w_2 = 1.5 + 1.5 \cos(t)$ (lower-left). Note that the value of these perturbations is not taken into account for the design. For comparison purposes,

the right-hand side of Figure 5.1 shows the simulations results of the same system (5.8) with and without perturbations, in closed loop with a linear feedback

$$\begin{bmatrix} u_1 \\ u_2 \end{bmatrix} = \begin{bmatrix} -2x_1 - x_2 \\ -x_1 - 2x_2 \end{bmatrix}. \quad (5.10)$$

The theoretical results are validated through the simulations, which show that the trajec-

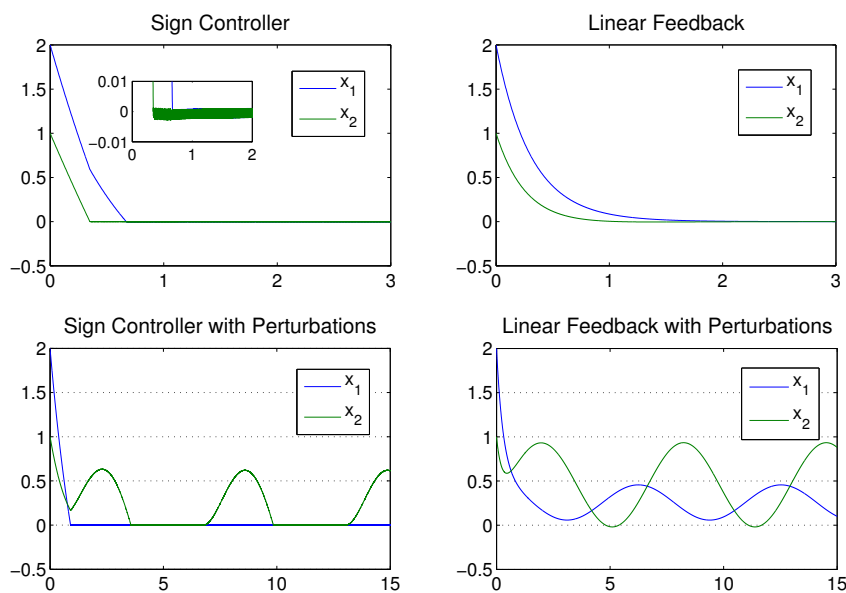

Figure 5.1: Simulations results of system (5.8) with control (5.9), and with control (5.10).

tories of the system converge to the origin for the unperturbed case, and to a vicinity of the origin when the perturbations are present. Moreover, from the zooms it is noticeable that they do this in finite-time, as opposed to the asymptotic convergence that the linear feedback achieves. Also, from the graph at the bottom-left it is noticeable that when the perturbation is small, which is the case of the equation \dot{x}_1 , it is rejected by the sign controller.

5.3 Stabilization of chain of integrators by n -sign feedback by the design of the switching surfaces

One of the simplest representations of a linear system's dynamics is through a chain of integrators with a control input u in the last equation, that is, a system in the form

$$\dot{x}_1 = x_2, \quad \dot{x}_2 = x_3, \quad \dots, \quad \dot{x}_n = u. \quad (5.11)$$

When the control input is defined as

$$u = -k_1 \operatorname{sign}(x_1) - \dots - k_n \operatorname{sign}(x_n),$$

the closed loop switches on the axis of each of the coordinates, which matches the description of the class of systems considered in the previous sections. As was mentioned in the introduction, the global convergence of the solutions to the origin has only been proven for orders $n = 1$ (conventional sliding mode controller [Utkin99]) and $n = 2$ (Twisting controller [Levant93]) for which the convergence and robustness properties are well known. However, in [Sánchez13] it has been proven that for $n = 3$, when none of the gains can majorate the sum of the other two, and with certain initial conditions, the trajectories converge to an equilibrium different from the origin and remain there for all future time. This last result prevented the investigations for orders of the system higher than 2. In this section we will consider the chain of integrators of n order, with fixed gains, when none of them can majorate the sum of the others. For this case we will define a set of n switching surfaces, as linear functions $f_i : \mathbb{R}^n \rightarrow \mathbb{R}$, $i = 1, \dots, n$, of x . We will also show that when the control input u is defined as

$$u = -k_1 \operatorname{sign}(f_1(x)) - \dots - k_n \operatorname{sign}(f_n(x)),$$

the closed loop is equivalent to special case of system (5.1) (when $A_0 = A_n^{int}$, and $A_1 = \begin{bmatrix} \vec{0}_{n-1 \times n} \\ -k_1 \dots - k_n \end{bmatrix}$ with fixed k_i) and thus, the results of the previous sections can be used to

prove the stability. Moreover, it will be shown that for the closed loop there exists a unique equilibrium point, and it is located at the origin. This is achieved through a simple linear coordinate transformation. To this end, we will start with a chain of integrators (5.11), define the linear transformation that shows the equivalency to (5.1), and then develop the structure of the surfaces and the controller and prove its convergence.

5.3.1 State transformation to a new set of coordinates

Define the coordinate transformation $z := Tx$ for (5.11), with invertible T given by

$$T = \begin{bmatrix} 1 & 0 & \dots & \dots & \dots & \dots & 0 \\ a_1 & 1 & \ddots & & & & \vdots \\ a_1 a_2 & a_1 + a_2 & \ddots & \ddots & & & \vdots \\ a_1 a_2 a_3 & a_1 a_2 + a_2 a_3 + a_1 a_3 & S_{1,3} & \ddots & \ddots & & \vdots \\ \vdots & S_{3,4} & S_{2,4} & \ddots & \ddots & \ddots & \vdots \\ \vdots & \vdots & \ddots & \ddots & \ddots & \ddots & 0 \\ \prod_{i=1}^{n-1} a_i & S_{n-2,n-1} & \dots & S_{3,n-1} & S_{2,n-1} & S_{1,n-1} & 1 \end{bmatrix}, \quad (5.12)$$

for some real constant scalars a_i ($i = 1 \dots n - 1$), and with

$$\begin{aligned} S_{1,3} &:= \sum_{i=1}^3 a_i = a_1 + a_2 + a_3, & S_{1,n-1} &:= \sum_{i=1}^{n-1} a_i, \\ S_{2,4} &:= \sum_{\substack{j,k=1,\dots,4 \\ j \neq k}} a_j a_k = a_1 a_2 + a_1 a_3 + a_1 a_4 + a_2 a_3 + a_2 a_4 + a_3 a_4, \\ S_{2,n-1} &:= \sum_{\substack{j,k=1,\dots,n-1 \\ j \neq k}} a_j a_k, \\ S_{3,4} &:= \sum_{\substack{j,k,l=1,\dots,4 \\ j \neq k \neq l}} a_j a_k a_l = a_1 a_2 a_3 + a_2 a_3 a_4 + a_3 a_4 a_1 + a_4 a_1 a_2, \\ S_{3,n-1} &:= \sum_{\substack{j,k,l=1,\dots,n-1 \\ j \neq k \neq l}} a_j a_k a_l. \end{aligned}$$

Note that element $S_{n-2,n-1}$, following the established sequence, would be the sum of the multiplication of $n - 2$ elements $(a_j a_k a_l \dots)$, for $j, k, l, \dots = 1, \dots, n - 1$. For example, for $n = 7$: $S_{n-2,n-1} = S_{5,6} = a_1 a_2 a_3 a_4 a_5 + a_2 a_3 a_4 a_5 a_6 + a_3 a_4 a_5 a_6 a_1 + a_4 a_5 a_6 a_1 a_2 + a_5 a_6 a_1 a_2 a_3 + a_6 a_1 a_2 a_3 a_4$. In the coordinates z the system has the form

$$\begin{aligned}\dot{z}_1 &= -a_1 z_1 + z_2 \\ \dot{z}_2 &= -a_2 z_2 + z_3 \\ &\vdots \\ \dot{z}_{n-1} &= -a_{n-1} z_{n-1} + z_n \\ \dot{z}_n &= \bar{C}^T z + u,\end{aligned}$$

where $\bar{C} := ((TA_n^{int}T^{-1})^T)^{[n]} = [c_1 \ \dots \ c_n]^T$. If for the above system the control law is selected as

$$u = -k_1 \text{sign}(z_1) - \dots - k_n \text{sign}(z_n), \quad (5.13)$$

and defining vectors $B, C \in \mathbb{R}^n$ as

$$B = \begin{bmatrix} 0 \\ \vdots \\ 0 \\ 1 \end{bmatrix}, \quad C = \begin{bmatrix} c_1 \\ \vdots \\ c_{n-1} \\ c_n + a_n \end{bmatrix}, \quad (5.14)$$

it can be written in the form

$$\dot{z} = A_0 z + A_1 \vec{\text{sign}}(z) + BC^T z, \quad (5.15)$$

where

$$A_0 = \begin{bmatrix} -a_1 & 1 & 0 & \dots & 0 \\ 0 & -a_2 & 1 & \ddots & \vdots \\ \vdots & \ddots & \ddots & \ddots & 0 \\ \vdots & & \ddots & \ddots & 1 \\ 0 & \dots & \dots & 0 & -a_n \end{bmatrix}, \quad A_1 = \begin{bmatrix} \vec{0}_{(n-1 \times n)} \\ -K \end{bmatrix}, \quad (5.16)$$

where $K = \begin{bmatrix} k_1 & \dots & k_n \end{bmatrix}$. If $C = 0$ in (5.15), then the transformed system corresponds to a special form of (5.1), and the term $BC^T z$ can be interpreted as a Lipschitz perturbation.

Remark 6 Note that each variable z_i , $\forall i = 1, \dots, n$, is equivalent to a linear combination of the states x of (5.11), given by $z_i = \bar{T}_i^T x$, where $\bar{T}_i = (T^T)^{[i]}$, so the controller (5.13) is equivalent to the form $u = -k_1 \text{sign}(f_1(x)) - \dots - k_n \text{sign}(f_n(x))$ mentioned earlier, with

$$\begin{aligned} f_1(x) &= x_1 \\ f_2(x) &= a_1 x_1 + x_2 \\ f_3(x) &= a_1 a_2 x_1 + (a_1 + a_2) x_2 + x_3 \\ &\vdots \end{aligned}$$

where each of the f_i represents one of the n surface on which the closed loop will switch.

Remark 7 In the case of a given switched system with dynamics

$$\begin{aligned} \dot{x} &= \tilde{A}_{0s} x + \tilde{A}_{1s} \vec{\text{sign}}(T_s x) + \tilde{B} u \\ y &= x, \end{aligned}$$

where $T_s x$ ($T_s \in \mathcal{R}^{n \times n}$ nonsingular) determines the form of n linear switching surfaces, defining the coordinates $z = T_s x$ and carrying out a transformation as above, one gets the equivalent system

$$\dot{z} = \bar{A}_0 z + A_1 \vec{\text{sign}}(z) + B_z u. \quad (5.17)$$

Then, a linear control $u = Kz$ can be designed for (5.17) such that the stability of the closed loop can be checked with the conditions of Theorem 5 for $A_0 = (\bar{A}_{z0} + B_z K)$ and A_1 .

5.3.2 Convergence to the origin of an n -signs controller

In the previous section a new set of switching surfaces z was defined, as well as an n -sign controller for the chain of integrators (5.11), that switches on these surfaces. In

the following theorem some conditions to guarantee the convergence to the origin of the closed-loop system are established.

Theorem 7 *If for the chain of integrators (5.11) a control law is selected as (5.13), then every solution of the closed loop starting in the set*

$$\Omega = \{z \in \mathbb{R}^n : \|z\| < \kappa\},$$

where

$$\begin{aligned} \kappa &:= \frac{1}{2\lambda_{\max}(P)} \left[\sqrt{ng_{\max}^2 + 4\lambda_{\max}(P)\lambda_{\min}(P)\frac{\mu^2}{\alpha^2}} - \sqrt{n}g_{\max} \right], \\ \alpha &:= \lambda_{\min}(Q) - 2\lambda_{\max}(P)\text{m}\ddot{\text{a}}\text{x}\{C\}, \\ g_{\max} &:= \max_{1 \leq i \leq n} \{g_i\}, \\ \mu &:= \text{m}\ddot{\text{a}}\text{x}\{M\vec{1}_{(n \times 1)}\} \end{aligned}$$

and the matrices P , and Q , $G = \text{diag}(g)$ come from Theorem 5 for the nominal system (5.1), will asymptotically converge to the origin provided that the constants a_i and k_i are strictly positive for all $i = 1, \dots, n$, and they satisfy

$$\mu < 0, \quad \sum_{i=1}^{n-2} k_i < k_n.$$

Remark 8 *Note that the gains k_{n-1} does not appear in the condition for the gains, so the case when none of the values of k_i dominates the sum of the others is within the conditions of the theorem.*

Corollary 2 *If, additionally,*

$$\text{m}\ddot{\text{a}}\text{x}\{C\} \leq \frac{\lambda_{\min}(Q)}{2\lambda_{\max}(P)},$$

then every solution of the closed-loop system will asymptotically converge to the origin.

Proof The term $BC^T z$ in (5.15) can be considered as a perturbation to the nominal one (5.1). Therefore, first, the stability of the system for the case $C = 0$ will be shown and, second, the set of invariance for $C \neq 0$ will be evaluated. For the first part of the proof we will check the existence of a unique equilibrium at the origin, for the nominal system. To this end the matrix A_0 can be divided as $A_0 = \begin{bmatrix} A_0^u \in \mathbb{R}^{(n-1) \times n} \\ A_0^l \in \mathbb{R}^{1 \times n} \end{bmatrix}$, where the last line has been separated because the signs appear for \dot{z}_n only. The structure of A_0^u allows to express its n th column $A_0^{u[n]} \in \mathbb{R}^{n-1}$ as

$$A_0^{u[n]} = \sum_{i=1}^{n-1} \alpha_i A_0^{u[i]}, \quad \forall \alpha_i \neq 0.$$

Now, let us define some variables q as $q^T = [q_1 \ \dots \ q_n]$ and look for the values of q_i , $i = 1, \dots, n$ which annihilate A_0^u (which would represent the coordinates of the equilibrium point) that is

$$\begin{aligned} A_0^u b &= 0 \\ &= \sum_{i=1}^n q_i A_0^{u[i]} \\ &= \sum_{i=1}^{n-1} q_i A_0^{u[i]} + q_n \sum_{i=1}^{n-1} \alpha_i A_0^{u[i]} \\ &= \sum_{i=1}^{n-1} (q_i + q_n \alpha_i) A_0^{u[i]}. \end{aligned}$$

For the above to hold, either

$$q_n = 0 \Rightarrow q_i = 0, \quad \forall i = 1, \dots, n-1 \quad (5.18)$$

or

$$q_n \neq 0 \Rightarrow q_i = -q_n \alpha_i \neq 0, \quad \forall i = 1, \dots, n-1. \quad (5.19)$$

In the case of (5.18), the equilibrium point is at the origin. For the case of (5.19), since the equality should hold for all $\alpha_i \neq 0$, then q_n and all of the q_i are different from zero. It

follows necessarily that the arguments of all the signs in \dot{z}_n would be different from zero and then it must hold that $\dot{z}_n \neq 0$. In this case the system has not reached an equilibrium, and therefore, it has been proven that the only equilibrium point is at the origin. Now we will check the boundedness, the region of attraction and the stability of the nominal system's solutions. To this end, consider the Lyapunov function (5.3) satisfying $A_0^T P + P A_0 < -Q$, $P = P^T > 0$, $Q = Q^T > 0$, and $GA_1 = 0$ (see Theorem 5 for the details). From the following expression,

$$\lambda_{\min}(P)\|z\|^2 \leq V(z) \leq \lambda_{\max}(P)\|z\|^2 + g_{\max}\|z\|_1,$$

we can see that since P is positive definite, $V(z) > 0 \forall x \neq 0$, and that the function is radially unbounded, *i.e.* $V(z) \rightarrow \infty$ as $\|z\| \rightarrow \infty$. Using inequality (1.3), the derivative of (5.3) along the nominal part of (5.15) can be expressed as

$$\begin{aligned} \dot{V} &= -z^T Q z + \text{sign}^T(z) R z \\ &\leq -\lambda_{\min}(Q)\|z\|^2 + \mu\|z\|_1, \end{aligned}$$

where μ has been defined in Theorem 7. Since $\mu < 0$, which is equivalent to establishing a strict inequality for the condition on M in Theorem 5, the derivative of the Lyapunov function can be expressed as

$$\begin{aligned} \dot{V} &\leq -\lambda_{\min}(Q)\|z\|^2 - |\mu|\|z\|_1 \\ &\leq -\lambda_{\min}(Q)\|z\|^2 - |\mu|\|z\|. \end{aligned}$$

It is evident that in this case $\dot{V} < 0$ for all $z \neq 0$. From section 5.1 we have that $M = R_d + |R \vec{R}_d|$, so μ is equal to the maximum of all the column sums of M . Since A_0 is a Metzler matrix, then the first condition of Theorem 5 can be solved for a diagonal P , then

M , for $k_i > 0$ has the form

$$M = \begin{bmatrix} -a_1 g_1 & g_1 & 0 & \dots & -2k_1 P_{n,n} \\ 0 & -a_2 g_2 & g_2 & \ddots & \vdots \\ \vdots & \ddots & \ddots & \ddots & -2k_{n-2} P_{n,n} \\ \vdots & & \ddots & -a_{n-1} g_{n-1} & g_{n-1} - 2k_{n-1} P_{n,n} \\ 0 & \dots & \dots & 0 & -2k_n P_{n,n} \end{bmatrix}.$$

The last element of the product $M^T \vec{1}_{(n \times 1)}$ is

$$|g_{n-1} - 2k_{n-1} P_{n,n}| + 2P_{n,n} \sum_{i=1}^{n-2} k_i - 2k_n P_{n,n}.$$

Choosing $g_{n-1} = 2k_{n-1} P_{n,n}$, μ can be made negative by satisfying

$$\sum_{i=1}^{n-2} k_i < k_n$$

and

$$\begin{aligned} 0 < g_{n-2} < a_{n-1} g_{n-1}, \quad 0 < g_{n-3} < a_{n-2} g_{n-2}, \dots, \\ 0 < g_1 < a_2 g_2 \end{aligned}$$

for any choice of $a_i > 0$. This also satisfies the LMI restriction $G \geq 0$ of Theorem 5. The last restriction, $GA_1 = 0$ is achieved by simply choosing $g_n = 0$. Thus, the nominal system (5.1) with $C = 0$ has the only equilibrium at the origin, and if the LMIs of Theorem 5 are satisfied, then the system is globally asymptotically stable. For the perturbed case, when $C \neq 0$, assuming that $\mu < 0$ the derivative of (5.3) along (5.15) is

$$\begin{aligned} \dot{V}(z) &= -z^T Q z + z^T (CB^T P + PBC^T) z \\ &\quad + \vec{\text{sign}}^T(z) R z + \vec{\text{sign}}^T(z) GBC^T z \\ &\leq -\lambda_{\min}(Q) \|z\|^2 + 2\lambda_{\max}(P) \text{m}\vec{\text{a}}\text{x}\{C\} \|z\|^2 \\ &\quad - |\mu| \|z\|_1 \\ &\leq \alpha \|z\|^2 - |\mu| \|z\|. \end{aligned}$$

Note that in the above expression, the term $GBC^T = 0$, since by construction $GA_1 = 0$ and BC^T has the same structure as A_1 . First, consider the case when $\alpha > 0$, and define the set

$$\Omega_1 := \left\{ z \in \mathbb{R}^n : \dot{V} \leq 0 \right\} = \left\{ z \in \mathbb{R}^n : \|z\| \leq \frac{|\mu|}{\alpha} \right\},$$

and $\dot{V} < 0$ in the interior of the set Ω_1 for all $z \neq 0$. To find an invariant set inside Ω_1 , recall the definition of V from which we have that

$$\lambda_{\min}(P)\|z\|^2 \leq V(z) \leq \lambda_{\max}(P)\|z\|^2 + \sqrt{n} g_{\max}\|z\|,$$

and note that in order to have $z \in \Omega_1$ the following inequality has to be satisfied:

$$V(z) \leq \lambda_{\min}(P) \frac{\mu^2}{\alpha^2},$$

which is true if

$$\lambda_{\max}(P)\|z\|^2 + \sqrt{n} g_{\max}\|z\| \leq \lambda_{\min}(P) \frac{\mu^2}{\alpha^2}.$$

Solving the last inequality with respect to $\|z\|$ we obtain

$$\|z\| \leq \kappa,$$

then $\Omega = \{z \in \mathbb{R}^n : \|z\| < \kappa\} \subset \Omega_1$ and every solution starting in Ω will remain inside in Ω for all $t \geq 0$, in addition

$$\dot{V} < 0 \quad \forall z \in \Omega \setminus \{0\},$$

therefore, all trajectories will converge to the origin for the initial conditions in Ω . Theorem 7 is proven. For the case when $\alpha \leq 0$, it is easy to see that $\dot{V}(z) \leq 0$ for all z , and $\dot{V}(z) = 0$ only at the origin, so in this case the perturbed system is globally stable. For this, the following inequality has to be satisfied

$$\text{m}\ddot{\alpha}\{C\} \leq \frac{\lambda_{\min}(Q)}{2\lambda_{\max}(P)},$$

which proves Corollary 2.

5.3.3 Convergence to the origin of an n -sign controller with an added linear term

The relevance of studying controllers that depend only on a sum of sign functions has been mentioned earlier in this work but, in specific applications, it could also be the case that the measurements of the states are reliable enough to use for control. Thus, the design of a controller that contains a linear feedback is also interesting (mainly due to its robustness with respect to unmatched disturbances). This section will explore this case, and consider a control law that includes the signs of the functions defined in the previous section, and also a linear combination of the states z (and, hence, of x). Such controller is defined in the following theorem, which also establishes the conditions for its design that guarantee the convergence of all solutions of (5.11) to the origin.

Theorem 8 *If for the chain of integrators (5.11) a control law is selected as*

$$u = -K\text{sign}(\vec{z}) - Cz - a_n z_n,$$

then every solution of the closed-loop system will converge to the origin asymptotically provided that the constants a_i and k_i , for all $i = 1, \dots, n$ are chosen strictly positive, and the latter satisfy

$$\mu < 0, \quad \sum_{i=1}^{n-2} k_i < k_n.$$

Proof System (5.11) in closed loop with a controller $u = -K\text{sign}(\vec{z}) - \bar{C}z - a_n z_n$ takes the form of (5.1) with

$$A_0 = \begin{bmatrix} -a_1 & 1 & 0 & \dots & 0 \\ 0 & -a_2 & 1 & \ddots & \vdots \\ \vdots & \ddots & \ddots & \ddots & 0 \\ \vdots & & \ddots & \ddots & 1 \\ 0 & \dots & \dots & 0 & -a_n \end{bmatrix}, \quad A_1 = \begin{bmatrix} \vec{0}_{(n-1 \times n)} \\ -K \end{bmatrix},$$

which is the same as system (5.15) with $C = 0$. Next, the proof follows the arguments demonstrated in the proof of Theorem 7.

5.3.4 Example

Consider a perturbed chain of four integrators

$$\dot{x}_1 = x_2, \quad \dot{x}_2 = x_3, \quad \dot{x}_3 = x_4 + w_1, \quad \dot{x}_4 = u + w_2,$$

with control

$$u = \begin{bmatrix} -2 & -2 & -2 & -5 \end{bmatrix} \text{sign}(\vec{f}) + \begin{bmatrix} c_1 & c_2 & c_3 & c_4 \end{bmatrix} x \quad (5.20)$$

Choosing parameters $a_1 = a_2 = a_3 = a_4 = 1$, the matrix T of (5.12) yields the form

$$T = \begin{bmatrix} 1 & 0 & 0 & 0 \\ 1 & 1 & 0 & 0 \\ 1 & 2 & 1 & 0 \\ 1 & 3 & 3 & 1 \end{bmatrix}.$$

Then, the switching surfaces are

$$\begin{bmatrix} f_1 \\ f_2 \\ f_3 \\ f_4 \end{bmatrix} = \begin{bmatrix} x_1 \\ x_1 + x_2 \\ x_1 + 2x_2 + x_3 \\ x_1 + 3x_2 + 3x_3 - x_4 \end{bmatrix}.$$

The set of linear gains are chosen according to Theorem 8 as

$$\begin{bmatrix} c_1 & c_2 & c_3 & c_4 \end{bmatrix} = \begin{bmatrix} 0 & -1 & -3 & -3 \end{bmatrix}$$

In Fig. 5.2 the simulation results are shown, when the external input w_1 is equal to zero and $w_2 = 0.5 + \sin(t)$, with a sampling step of 0.0001s and initial conditions

$$x_1(0) = 20, \quad x_2(0) = -30, \quad x_3(0) = 25, \quad x_4(0) = -35. \quad (5.21)$$

For this case we have a fourth order chain of integrators subjected to a matched perturbation, which is a standard consideration in the sliding-mode literature. From the zooms made to the simulation results, it is again noticeable that the convergence to zero is in a finite time. Now, for the same initial conditions (5.21), the simulation results are presented

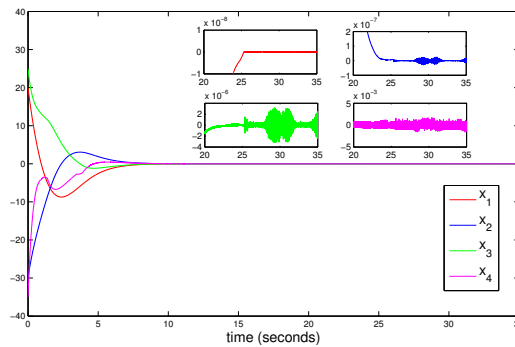

Figure 5.2: State trajectories of the perturbed quadruple integrator with the control (5.20) and the initial conditions (5.21), when the external input $w_1 = 0$ and $w_2 = 0.5 + \sin(t)$

in Fig. 5.3, when the disturbance w_1 was chosen as a white noise signal and $w_2 = 0$. In this case it is worth to highlight that despite the system has an unknown and unmatched external perturbation, which in this case is white noise, the state trajectories still converge to a vicinity of the origin, as expected from the ISS property of the closed loop, described in section 5.2. Even more, from the results developed in that section, it is easy to calculate an upper bound of the norm of the state as

$$\|z(t)\| \leq \sqrt{35.8685\|w\|^4 + 640.9432\|w\|^3 + 3264.2\|w\|^2 + 3581.7\|w\|},$$

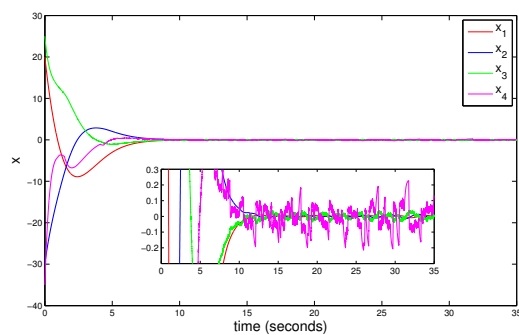

Figure 5.3: State trajectories of the perturbed quadruple integrator with the control (5.20) and the initial conditions (5.21), when the external input w_1 is white noise and $w_2 = 0$

Chapter 6

Conclusions

6.1 Concluding Remarks

In this work a solution for the output-feedback problem, with matched and unmatched disturbances and unstable zero dynamics is presented. The approach overcomes the relative degree one condition imposed on the output in the majority of the works available in the literature. The methodology includes

- a generalized way of transforming a linear uncertain system with only part of the state available in the output, regardless of its relative degree, into a special regular form.
- a procedure for obtaining a reduced order system that maintains controllability and observability properties
- the definition of a reduced order (virtual) controller, that depends on the dynamics of an observer that is also designed.
- the proposal of a sliding variable such that, when it reaches zero, the zero dynamics become stable and it is guaranteed that this controller acts as desired on the zero dynamics.

On the other hand, the ISS properties of two sliding-mode controllers was studied: firstly, it was shown that the properties of a conventional sliding-mode controller can be combined with those of a linear term, in order to achieve enhanced global robustness of the closed loop against matched and unmatched perturbations. Moreover, it was shown that the closed loop shows an ISS behavior with respect to the matched and unmatched disturbances. Afterwards, a continuous Lyapunov function that recently appeared in the literature was used to prove the ISS property of the ST. For both cases sufficient conditions for the gains of the controllers were derived using standard ISS tools such as ISS-Lyapunov functions and the classical small gain theorem. With this, robustness against not only matched, but also unmatched perturbations, of which an upper bound might not be known, is guaranteed, overcoming the classical limitation of the sliding-modes controllers about the matchedness of the perturbations, as well as the necessity of knowing the value for an upper bound for them.

Another problem is considered in the last chapter of this document, this is the stabilization problem of switched systems in which switchings occur on the axes of its state coordinates. A stabilizing linear feedback, or a combination of the linear feedback and a switching law were designed such that the stability of the closed loop can be checked through the established linear matrix inequalities. Moreover, the ISS property of such a class of systems has been quantified, guaranteeing robustness against matched and unmatched perturbations. As an auxiliary result, the stabilization problem of a chain of n integrators with an n sign controller was considered, when the gains of the controller are fixed, and none of them can dominate the sum of the others. For this case the switching surfaces are designed such that the trajectories of the closed loop converge to a unique equilibrium point at the origin, as opposed to what was shown in before for the orders three and greater. In order to illustrate the results, two examples have been provided: a triple integrator and a fourth order integrator, both controlled by as many signs as the

order of the system, with fixed gains. The results of the simulations are consistent with the theoretical ones. Even though the proofs guarantee only asymptotic convergence to the origin, the simulations show evidence that the convergence is actually achieved in a finite time. Moreover, the ISS gain function of the system with respect to external inputs has been explicitly calculated.

This work is the result of original research, and the results have undergone peer reviews and then published in several prestigious conference proceedings and in a well-known indexed journal. The methodology presented is a novel approach to the OFSM problem, and thus it represents a significant contribution to the control theory.

6.2 List of Publications

During the development of this work the following publications were produced:

Accepted conference publications

- *Dynamic surface for output feedback sliding modes, the case of relative degree two*, A. Aparicio Martínez, F. Castaños and L. Fridman, 52nd IEEE Conference on Decision and Control, Firenze, 2013, pp. 3578-3583.

doi: 10.1109/CDC.2013.6760433

Abstract: A general transformation that takes linear systems into their regular form, for any relative degree is introduced. A sliding surface where unmatched unknown inputs are attenuated via a reduced order H_∞ control is designed, for the case of relative degree two. By a discontinuous control action, the surface is reached exactly in finite time, guaranteeing the minimization of the unmatched disturbance. Complete state measurements are not necessary.

- *ISS-Lyapunov functions for output feedback sliding modes,*

A. Aparicio Martínez, F. Castaños and L. Fridman,

53rd IEEE Conference on Decision and Control, Los Angeles, CA, 2014,

pp. 5536-5541.

doi: 10.1109/CDC.2014.7040255

Abstract: In this paper we address the problem of establishing conditions for global asymptotic stability in output feedback sliding-mode control. The proposed methodology introduces a linear term in a first-order sliding-mode controller. This allows to characterize the closed loop with the input-to-state stability property. Also, a Lyapunov-based methodology to find the correct gains for this controller is presented.

- *ISS properties of sliding-mode controllers for systems with matched and unmatched disturbances,*

A. A. Martínez, F. Castaños and L. Fridman,

2015 European Control Conference (ECC), Linz, 2015,

pp. 2865-2870.

doi: 10.1109/ECC.2015.7330972

Abstract: In this paper we present a controller that achieves global input-to-state stability for a linear system of arbitrary relative degree, subjected to matched and unmatched disturbances. This controller combines the properties of a discontinuous term, and a linear one, enforcing a conventional sliding mode using only partial state information. A direct and simple way of choosing the gains for this controller is also provided.

- *ISS-Lyapunov functions for output feedback sliding modes,*

A. Aparicio, D. Efimov and L. Fridman,

2016 IEEE 55th Conference on Decision and Control (CDC), Las Vegas, NV, USA, 2016,

pp. 7306-7311.

doi: 10.1109/CDC.2016.7799397

Abstract: In this paper we revisit the problem of stabilizing a triple integrator using a control that depends on the signs of the state variables. For a more general class of linear systems it is shown that the stabilization by sign feedback is possible, depending on some properties of the system's matrix. The conditions for the stability are established by means of linear matrix inequalities. For the triple integrator, the domain of stability is evaluated. Also, the control law is augmented by a linear feedback and the stability properties for this case, checked. The results are illustrated by numerical experiments for a chain of integrators of third order.

Published journal publications

- *Output feedback sliding-mode control with unmatched disturbances, an ISS approach.*

Aparicio, A., Castaños, F., and Fridman, L.

2016

Int. J. Robust. Nonlinear Control, 26: 4056–4071.

doi: 10.1002/rnc.3548.

Abstract: The robustness properties of a first-order sliding-mode controller are combined with those of an added linear term in order to obtain a closed loop that shows input-to-state stability with respect to matched and unmatched disturbances, of which an upper bound might not be known, using only output information. The output under consideration can have any relative degree. Also, a transformation of the state into a novel output normal form is presented. The zero dynamics are considered unstable and perturbed, so a methodology for defining an observer and a virtual control for it is presented.

Submitted journal publications

- *Stabilization of switched systems by linear feedbacks and its ISS properties*

Andrea Aparicio, Leonid Fridman, Denis Efimov

IET Control Theory & Applications

Abstract: The stabilization problem for switched systems in which switchings occur on the axes of its state coordinates is considered. It is shown that a linear feedback, or a combination of linear feedback and a switching law, can be design such that the closed-loop is stable. The conditions of stability are expressed in the form of linear matrix inequalities. The input-to-state stability property of the closed-loop system is established, allowing to guarantee robustness against matched and unmatched perturbations. The results are illustrated by numerical simulations.

Status: Under review

Manuscripts in preparation

- *Continuous Output-Feedback Sliding-Mode Control with Unmatched Perturbations: an ISS approach*

Aparicio, A., Castaños, F., and Fridman, L.

Bibliography

- [Angeli00] Angeli, D., Sontag, E., y Wang, Y. A characterization of integral input-to-state stability. *IEEE Trans. Automat. Control*, 45(6):1082–1097, 2000.
- [Angulo13] Angulo, M. T., Fridman, L., y Moreno, J. Output-feedback finite-time stabilization of disturbed feedback linearizable nonlinear systems. *Automatica*, 49(9):2767 – 2773, 2013. ISSN 0005-1098. doi: <http://dx.doi.org/10.1016/j.automatica.2013.05.013>.
- [Bag97] Bag, S., Spurgeon, S., y Edwards, C. Output feedback sliding mode design for linear uncertain systems. *Control Theory and Applications, IEE Proceedings -*, 144(3):209–216, 1997. ISSN 1350-2379. doi: 10.1049/ip-cta:19971122.
- [Bernuau13] Bernuau, E., Polyakov, A., Efimov, D., Perruquetti, W., et al. On ISS and iISS properties of homogeneous systems. *En European Control Conference 2013*. 2013.
- [Castaños11] Castaños, F. y Fridman, L. Dynamic switching surfaces for output sliding mode control: An H_∞ approach. *Automatica*, 47(9):1957 – 1961, 2011. ISSN 0005-1098. doi:10.1016/j.automatica.2011.05.012.

- [Chen98] Chen, C. *Linear System Theory and Design*. Oxford University Press, Inc., New York, NY, USA, 3^a ed^{ón}., 1998. ISBN 0195117778.
- [Choi08] Choi, H. Sliding mode output feedback control design. *Transactions on Industrial Electronics*, 55(11), 2008.
- [Dashkovskiy11a] Dashkovskiy, S., Efimov, D., y Sontag, E. Input to state stability and allied system properties. *Automation and Remote Control*, 72(8):1579–1614, 2011.
- [Dashkovskiy11b] Dashkovskiy, S., Kosmykov, M., y Wirth, F. A small-gain condition for interconnections of ISS systems with mixed ISS characterizations. *Automatic Control, IEEE Transactions on*, 56(6):1247–1258, June 2011. ISSN 0018-9286. doi:10.1109/TAC.2010.2080110.
- [Davila13] Davila, J. Exact tracking using backstepping control design and high-order sliding modes. *IEEE Transactions on Automatic Control*, pág. 452–457, 2013. doi:10.1109/TAC.2013.2246894.
- [Doyle89] Doyle, J., Glover, K., Khargonekar, P., y Francis, B. State-space solutions to standard H_2 and H_∞ control problems. *IEEE Transactions on Automatic Control*, 34(8):831–847, 1989. ISSN 0018-9286. doi:10.1109/9.29425.
- [Ferreira14] Ferreira, A., Punta, E., Fridman, L., Bartolini, G., y S., D. Nested backward compensation of unmatched perturbations via {HOSM} observation. *Journal of the Franklin Institute*, 351(5):2397 – 2410, 2014. ISSN 0016-0032. doi: <http://dx.doi.org/10.1016/j.jfranklin.2013.12.011>.
- [Ferreira15] Ferreira, A., Cieslak, J., Henry, D., Zolghadri, A., y Fridman, L. Output tracking of systems subjected to perturbations and a

- class of actuator faults based on {HOSM} observation and identification. *Automatica*, 59:200 – 205, 2015. ISSN 0005-1098. doi: <http://dx.doi.org/10.1016/j.automatica.2015.06.020>.
- [Horn90] Horn, R. y Johnson, C. *Matrix Analysis*. Cambridge University Press, 1990. ISBN 9780521386326.
URL <https://books.google.fr/books?id=PLYQN0ypTwEC>
- [Isidori95] Isidori, A. *Nonlinear Control Systems*. N^o v. 1 en Communications and Control Engineering. Springer, 1995. ISBN 9783540199168.
- [Jiang96] Jiang, Z., Mareels, I., y Wang, Y. A Lyapunov formulation of the nonlinear small-gain theorem for interconnected ISS systems. *Automatica*, 32(8):1211 – 1215, 1996. ISSN 0005-1098.
- [Johansson98] Johansson, M. y Rantzer, A. Computation of piecewise quadratic lyapunov functions for hybrid systems. *IEEE Transactions on Automatic Control*, 43(4):555–559, Apr 1998. ISSN 0018-9286.
- [Kanellakopoulos92] Kanellakopoulos, I., Kokotovic, P., y Morse, A. A toolkit for nonlinear feedback design. *Systems and Control Letters*, 18(2):83 – 92, 1992. ISSN 0167-6911. doi:[http://dx.doi.org/10.1016/0167-6911\(92\)90012-H](http://dx.doi.org/10.1016/0167-6911(92)90012-H).
- [Khalil02] Khalil, H. *Nonlinear Systems*. Prentice Hall PTR, 2002. ISBN 9780130673893.
- [Kimura75] Kimura, H. Pole assignment by gain output feedback. *IEEE Transactions on Automatic Control*, 20(4):509–516, 1975. ISSN 0018-9286. doi:10.1109/TAC.1975.1101028.

- [Levant93] Levant, A. Sliding order and sliding accuracy in sliding mode control. *International Journal of Control*, 58(6):1247–1263, 1993.
- [Levant98] Levant, A. Robust exact differentiation via sliding mode technique. *Automatica*, 34(3):379–384, 1998.
- [Levant05] Levant, A. Homogeneity approach to high-order sliding mode design. *Automatica*, 41(5):823–830, mayo 2005. ISSN 0005-1098.
- [Levant07] Levant, A. Principles of 2-sliding mode design. *Automatica*, 43(4):576–586, 2007.
- [Luk’yanov81] Luk’yanov, A. y Utkin, V. Methods for reduction of equations of dynamic systems to a regular form. *Automation and Remote Control*, 1981. doi:10.1093/imamci/dnr036.
- [Moreno12] Moreno, J. A. y Osorio, M. Strict lyapunov functions for the super-twisting algorithm. *IEEE Transactions on Automatic Control*, 57(4):1035–1040, April 2012. ISSN 0018-9286. doi:10.1109/TAC.2012.2186179.
- [Oliveira15] Oliveira, T. R., Estrada, A., y Fridman, L. M. Global exact differentiator based on higher-order sliding modes and dynamic gains for globally stable output-feedback control. *En Decision and Control (CDC), 2015 IEEE 54th Annual Conference on*, págs. 4109–4114. Dec 2015. doi:10.1109/CDC.2015.7402859.
- [Petterson97] Petterson, S. y Lennartson, B. Lmi for stability and robustness of hybrid systems. *En Proceedings of the 1997 American Control Conference (Cat. No.97CH36041)*, tomo 3, págs. 1714–1718 vol.3. Jun 1997. ISSN 0743-1619.

- [Shorten07] Shorten, R., Wirth, F., Mason, O., Wulff, K., y King, C. Stability criteria for switched and hybrid systems. *SIAM reviews*, 2007.
- [Sontag89] Sontag, E. Smooth stabilization implies coprime factorization. *Automatic Control, IEEE Transactions on*, 34(4):435–443, Apr 1989. ISSN 0018-9286. doi:10.1109/9.28018.
- [Sontag95] Sontag, E. y Wang, Y. On Characterizations of the Input-to-State Stability Property. *Systems and Control Letters*, 24(5):351 – 359, 1995. ISSN 0167-6911. doi:http://dx.doi.org/10.1016/0167-6911(94)00050-6.
- [Sontag99] Sontag, E. y Teel, A. Changing supply functions in input/state stable systems. *IEEE Trans. Automat. Control*, 40:1476–1478, 1999.
- [Sánchez13] Sánchez, T. y Moreno, J. On a sign controller for the triple integrator. *En Decision and Control (CDC), 2013 IEEE 52nd Annual Conference on*, págs. 3566–3571. Dec 2013. ISSN 0743-1546. doi:10.1109/CDC.2013.6760431.
- [Sánchez14] Sánchez, T. y Moreno, J. Un metodo de construccion de funciones de lyapunov para una clase de sistemas homogeneos. *En XVI Congreso Latinoamericano de Control Automatico CLCA 2014*. 2014.
- [Utkin92] Utkin, V. *Sliding modes in control and optimization*, tomo 116. Springer-Verlag Berlin, 1992.
- [Utkin99] Utkin, V. *Sliding Modes in Electro Mechanical Systems*. Taylor and Francis, 1999.
- [Wicks94] Wicks, M. A., Peleties, P., y DeCarlo, R. A. Construction of piecewise lyapunov functions for stabilizing switched systems. *En Proceedings*

of 1994 33rd IEEE Conference on Decision and Control, tomo 4, págs.
3492–3497 vol.4. Dec 1994. doi:10.1109/CDC.1994.411687.